

Varazdin Development and Entrepreneurship Agency and University North  
in cooperation with  
University of Aveiro  
Faculty of Management University of Warsaw  
Faculty of Law, Economics and Social Sciences Sale - Mohammed V University in Rabat  
Polytechnic of Medimurje in Cakovec



# Economic and Social Development

56<sup>th</sup> International Scientific Conference on Economic and Social Development

## Book of Proceedings

Editors:

Humberto Nuno Rito Ribeiro, Marco Andre da Silva Costa, Ivan Cehok



ISSN 1849-7535



9 771849 753006 >

Aveiro, 02-03 July 2020

**Varazdin Development and Entrepreneurship Agency and University North**  
in cooperation with  
**University of Aveiro**  
**Faculty of Management University of Warsaw**  
**Faculty of Law, Economics and Social Sciences Sale - Mohammed V University in Rabat**  
**Polytechnic of Medimurje in Cakovec**

Editors:

**Humberto Nuno Rito Ribeiro, University of Aveiro, Portugal**  
**Marco Andre da Silva Costa, University of Aveiro, Portugal**  
**Ivan Cehok, City of Varazdin, Croatia**

## **Economic and Social Development**

56<sup>th</sup> International Scientific Conference on Economic and Social Development

### **Book of Proceedings**

Aveiro, 02-03 July 2020

**Editors** ■ Humberto Nuno Rito Ribeiro, Marco Andre da Silva Costa, Ivan Cehok

**Scientific Committee / Programski Odbor** ■ Marijan Cingula (President), University of Zagreb, Croatia; Sannur Aliyev, Azerbaijan State University of Economics, Azerbaijan; Sandra Raquel Alves, Polytechnic of Leiria, Portugal; Ayuba A. Aminu, University of Maiduguri, Nigeria; Marlene Paula Castro Amorim, University of Aveiro, Portugal; Anona Armstrong, Victoria University, Australia; Gouri Sankar Bandyopadhyay, The University of Burdwan, India; Haimanti Banerji, Indian Institute of Technology, India; Victor Beker, University of Buenos Aires, Argentina; Asmae Benthani, Mohammed V University, Morocco; Alla Bobileva, The Lomonosov Moscow State University, Russia; Leonid K. Bobrov, State University of Economics and Management, Russian Federation; Rado Bohinc, University of Ljubljana, Slovenia; Adnan Celik, Selcuk University, Turkey; Angelo Maia Cister, Federal University of Rio de Janeiro, Brazil; Luis Miguel Serra Coelho, University of Algarve, Portugal; Ana Alexandra Vilela Marta Rio Costa, University of Tras-Os-Montes and Alto Douro, Portugal; Marco Andre da Silva Costa, University of Aveiro, Portugal; Mirela Cristea, University of Craiova, Romania; Taoufik Daghi, Mohammed V University, Morocco; Oguz Demir, Istanbul Commerce University, Turkey; T.S. Devaraja, University of Mysore, India; Onur Dogan, Dokuz Eylul University, Turkey; Darko Dukic, University of Osijek, Croatia; Gordana Dukic, University of Osijek, Croatia; Alba Dumi, Vlora University, Albania; Galina Pavlovna Gagarinskaya, Samara State University, Russia; Mirjana Gligoric, Faculty of Economics - Belgrade University, Serbia; Mehmet Emre Gorgulu, Afyon Kocatepe University, Turkey; Klodiana Gorica, University of Tirana, Albania; Aleksandra Grobelna, Gdynia Maritime University, Poland; Liudmila Guzikova, Peter the Great Saint-Petersburg Polytechnic University, Russia; Anica Hunjet, University North, Croatia; Khalid Hammes, Mohammed V University, Morocco; Oxana Ivanova, Ulyanovsk State University, Russian Federation; Irena Jankovic, Faculty of Economics, Belgrade University, Serbia; Myrl Jones, Radford University, USA; Hacer Simay Karaalp, Pamukkale University, Turkey; Dafna Kariv, The College of Management Academic Studies, Israel; Hilal Yildirim Keser, Uludag University, Turkey; Sophia Khalimova, Institute of Economics and Industrial Engineering of Siberian Branch of Russian Academy of Science, Russian Federation; Marina Klacmer Calopa, University of Zagreb, Croatia; Igor Klopotan, Medjmursko Veleuciliste u Cakovcu, Croatia; Vladimir Kovsca, University of Zagreb, Croatia; Goran Kozina, University North, Croatia; Dzenan Kulovic, Univeristy of Zenica, Bosnia and Herzegovina; Robert Lewis, Les Roches Gruyere University of Applied Sciences, Switzerland; Ladislav Lukas, Univ. of West Bohemia, Faculty of Economics, Czech Republic; Mustapha Machrafi, Mohammed V University, Morocco; Liliane Cristina Segura Mackenzie, Presbyterian University, Brazil; Daniel Margaca Magueta, University of Aveiro, Portugal; Joao Jose Lourenco Marques, University of Aveiro, Portugal; Pascal Marty, University of La Rochelle, France; Vaidotas Matutis, Vilnius University, Lithuania; Carlos Alberto da Silva Menezes, University of Minho, Portugal; Daniel Francois Meyer, North West University, South Africa; Marin Milkovic, University North, Croatia; Raquel Filipa do Amaral Chambre de Meneses Soares Bastos Moutinho, University of Porto, Portugal; Abdelhamid Nechad, Abdelmalek Essaadi University, Morocco; Gratiela Georgiana Noja, West University of Timisoara, Romania; Zsuzsanna Novak, Corvinus University of Budapest, Hungary; Tomasz Ochynowski, University of Warsaw, Poland; Barbara Herceg Paksic, University of Osijek, Croatia; Vera Palea, Universita degli Studi di Torino, Italy; Dusko Pavlovic, Libertas International University, Croatia; Igor Pihir, University of Zagreb, Croatia; Dmitri Pletnev, Chelyabinsk State University, Russian Federation; Mirosław Przygoda, University of Warsaw, Poland; Karlis Purmalis, University of Latvia, Latvia; Nicholas Recker, Metropolitan State University of Denver, USA; Kerry Redican, Virginia Tech, Blacksburg, USA; David Nunes Resende, University of Aveiro, Portugal; Humberto Nuno Rito Ribeiro, University of Aveiro, Portugal; Robert Rybnicek, University of Graz, Austria; Amelia Cristina Ferreira da Silva, Polytechnic of Porto, Portugal; Joanna Stawska, University of Lodz, Poland; Elzbieta Szymanska, Bialystok University of Technology, Poland; Katarzyna Szymanska, The State Higher School of Vocational Education in Ciechanow, Poland; Iliana Tutore, University of Naples Parthenope, Italy; Rui Jose Oliveira Vieira, IE Business School, Spain; Ilko Vrankic, University of Zagreb, Croatia; Stanislaw Walukiewicz, Bialystok University of Technology, Poland; Thomas Will, Agnes Scott College, USA; Li Yongqiang, Victoria University, Australia; Peter Zabielskis, University of Macau, China; Silvija Zeman, Medjmursko Veleuciliste u Cakovcu, Croatia; Tao Zeng, Wilfrid Laurier University, Canada; Snezana Zivkovic, University of Nis, Serbia.

**Review Committee / Recenzentski Odbor** ■ Marina Klacmer Calopa (President); Humberto Nuno Rito Ribeiro (Vice-President); Ana Aleksic; Sandra Raquel Alves; Ayuba Aminu; Marlene Paula Castro Amorim; Mihovil Andjeljinovic; Josip Arneric; Lidija Bagaric; Tomislav Bakovic; Sanja Blazevic; Leonid Bobrov; Zuzica Brečić; Elisabeth de Jesus Oliveira Brito; Anita Ceh Casni; Iryna Chernysh; Angelo Maia Cister; Marco Andre da Silva Costa; Mirela Cristea; Oguz Demir; Marta Alexandra da Costa Ferreira Dias; Joana Maria Costa Martins das Dores; Stjepan Dvorski; Robert Fabac; Ivica Filipovic; Maria Alexandra Soares Fontes; Sinisa Franjic; Fran Galetic; Mirjana Gligoric; Tomislav Globan; Anita Goltnik Unaut; Maria Jose Angelico Goncalves; Tomislav Herceg; Irena Jankovic; Emina Jerkovic; Dafna Kariv; Oliver Kesar; Hilal Yildirim Keser; Martina Dragija Kostic; Tatjana Kovac; Vladimir Kovsca; Mara Teresa da Silva Madaleno; Katarina Marosevic; Vaidotas Matutis; Joao Jose Lourenco Marques; Marjana Merckac Skok; Daniel Francois Meyer; Natanya Meyer; Josip Mikulic; Ljubica Milanovic Glavan; Raquel Filipa do Amaral Chambre de Meneses Soares Bastos Moutinho; Guenter Mueller; Ivana Nacinovic Braje; Zlatko Nedelko; Gratiela Georgiana Noja; Zsuzsanna Novak; Alcina Maria de Almeida Rodrigues Nunes; Alka Obadic; Claudia Ogreen; Jose Manuel Teixeira Pereira; Igor Pihir; Najla Podrug; Vojko Potocan; Dinko Primorac; Zeljka Primorac; Nuno Manuel Rosa Dos Reis; David Nunes Resende; Sanda Renko; Humberto Ribeiro; Vlasta Roska; Souhaila Said; Armando Javier Sanchez Diaz; Joao Carvalho Santos; Tomislav Sekur; Ana Lorga da Silva; Amelia Cristina Ferreira da Silva; Lorena Skuflic; Mirko Smoljic; Petar Soric; Mario Spremic; Matjaz Stor; Tomasz Studzieniecki; Sandrina Francisca Teixeira; Lejla Tjanic; Daniel Tomic; Boris Tusek; Rebeka Daniela Vlahov; Ilko Vrankic; Thomas Will; Zoran Wittine; Tao Zeng; Grzegorz Zimon; Snezana Zivkovic; Berislav Zmuk.

**Organizing Committee / Organizacijski Odbor** ■ Domagoj Cingula (President); Humberto Nuno Rito Ribeiro (Vice-President); Djani Bunja; Marina Klacmer Calopa; Spomenko Kesina; Erlino Koscak; Tomasz Ochynowski; Mirosław Przygoda; Sandra Raquel Alves; Michael Stefulj; Rebeka Danijela Vlahov; Sime Vucetic; Marlene Paula Castro Amorim; Maria Cristina Goncalves Guardado; Mara Teresa da Silva Madaleno; David Nunes Resende; Marco Andre da Silva Costa; Marta Alexandra da Costa Ferreira Dias; Daniel Margaca Magueta; Joao Jose Lourenco Marques.

**Publishing Editor** ■ Spomenko Kesina, Mario Vrazic, Domagoj Cingula

**Publisher** ■ **Design** ■ **Print** ■ Varazdin Development and Entrepreneurship Agency, Varazdin, Croatia / University North, Koprivnica, Croatia / University of Aveiro, Aveiro, Portugal / Faculty of Management University of Warsaw, Warsaw, Poland / Faculty of Law, Economics and Social Sciences Sale - Mohammed V University in Rabat, Morocco / Polytechnic of Medimurje in Cakovec, Cakovec, Croatia

**Printing** ■ Online Edition

**ISSN 1849-7535**

The Book is open access and double-blind peer reviewed.

Our past Books are indexed and abstracted by ProQuest, EconBIZ, CPCI (Web of Science) and EconLit databases and available for download in a PDF format from the Economic and Social Development Conference website: <http://www.esd-conference.com>

© 2020 Varazdin Development and Entrepreneurship Agency, Varazdin, Croatia; University North, Koprivnica, Croatia; University of Aveiro, Aveiro, Portugal; Faculty of Management University of Warsaw, Warsaw, Poland; Faculty of Law, Economics and Social Sciences Sale - Mohammed V University in Rabat, Morocco; Polytechnic of Medimurje in Cakovec, Cakovec, Croatia. All rights reserved. Authors are responsible for the linguistic and technical accuracy of their contributions. Authors keep their copyrights for further publishing.

## **CONTENTS**

<b>TO IT-PROVIDER BUSINESS PROCESSES NETWORK MODEL .....</b>	<b>1</b>
Marina Purgina, Aleksey Dobrinin, Roman Koynov	
<b>FUNCTIONAL STRUCTURING OF AN ADAPTIVE IT-PROCESS MANAGEMENT SYSTEM .....</b>	<b>7</b>
Marina Purgina	
<b>RESEARCH OF THE PHENOMENON OF IMPLICIT KNOWLEDGE, ITS STRUCTURING AND MANAGEMENT IN THE DIGITAL ECONOMY BASED ON TRUST.....</b>	<b>15</b>
Petr Pashkov, Vasily Soloviev	
<b>INTELLECTUAL CAPITAL AND ITS COMPONENTS AS AN OBJECT OF ACCOUNTING .....</b>	<b>26</b>
Yana Ustinova	
<b>INTEGRAL ASSESSMENT OF RETAIL DIGITALIZATION.....</b>	<b>33</b>
Zhanna Shnorr	
<b>A PROACTIVE APPROACH TO THE IDENTIFICATION OF DELIBERATE BANKRUPTCY OF ECONOMIC ENTITIES: ADVANTAGES AND LIMITATIONS</b>	<b>40</b>
Mikhail Alekseev, Nina Vasiljeva	
<b>ECONOMIC, SOCIAL, AND INSTITUTIONAL DETERMINANTS OF DOMESTIC CONFLICT IN FRAGILE STATES.....</b>	<b>51</b>
Syed Muhammad All-e-Raza Rizvi, Marie-Ange Veganzones-Varoudakis	
<b>AN APPLICATION OF GENERATING FUNCTION AS A PROCESS ANALYSIS TOOL .....</b>	<b>61</b>
Adela Poliakova	
<b>KAIZEN COSTING: SYSTEMATIC LITERATURE REVIEW (2015-2020).....</b>	<b>71</b>
Pedro Miranda, Rui Silva, Amélia Ferreira da Silva, Carina Ferreira	
<b>US PRESIDENTS AS FOREIGN POLICY ACTORS: GEORGE W. BUSH AND BARACK OBAMA .....</b>	<b>86</b>
Tesa Klopota	
<b>FARMING ECONOMY IN FUNCTION OF THE LAND AREA: THE CASE OF DOURO WINEGROWING SYSTEMS.....</b>	<b>97</b>
Ana Marta-Costa	
<b>A DEEPER INSIGHT INTO POLITICAL BRAND TRUST – HOW TRUST IN PARTY'S LEADER AND PARTY'S PROGRAM INFLUENCES VOTING STABILITY? .....</b>	<b>102</b>
Ana Pap	

<b>APPROACHES IN MANAGEMENT IN A SELECTED SERVICE SECTOR FOCUSED ON CUSTOMER SATISFACTION.....</b>	<b>109</b>
Simona Jaculjakova, Dominik Laitkep, Peter Jucha	
<b>HOW TO IDENTIFY GROSS R&amp;D POTENTIAL IN INDUSTRY 4.0.....</b>	<b>116</b>
Miroslav Balog, Lubica Kotorova Slusna	
<b>STUDYING THE FACTORS INFLUENCING THE AUDITOR'S OPINION ON THE BUSINESS CONTINUITY OF THE AUDITED ENTITY.....</b>	<b>126</b>
Bibigul Amanzholova, Lidiya Nagovitsina, Galina Maksimova, Natalia Fadeykina	
<b>LEGAL IMPACT OF ROBOTS IN CIVIL LIABILITY AND TAXATION: WHAT WE KNOW, TRENDS AND CHALLENGES .....</b>	<b>135</b>
Catia Marques Cebola, Cristina Sa, Jose Luis Martins, Tiago Azevedo Ramalho	
<b>COMPOSITION AND DISTRIBUTION OF INNECA LARVAE (ODONATA LARVAE) IN LAKES AND WATERFALLS .....</b>	<b>144</b>
Sanubar Guliyeva	
<b>CAPITAL STRUCTURE OPTIMIZATION IN CONDITIONS OF THE SMALL AND MEDIUM-SIZED ENTERPRISES .....</b>	<b>148</b>
Juraj Cug	
<b>INFLUENCE OF TIME MANAGEMENT ON PERFORMANCE OF MANAGERS</b>	<b>155</b>
Darina Chlebikova	
<b>ECONOMIC FREEDOM AND BUSINESS PROFITABILITY.....</b>	<b>163</b>
Rita de Cassia de Lima Diniz, Henrique Formigoni, Liliane Cristina Segura	
<b>ENABLING OPEN DATA PARADIGM FOR BUSINESS IMPROVEMENT.....</b>	<b>174</b>
Larisa Hrustek, Martina Tomicic Furjan, Igor Pihir	
<b>SIGNIFICANT FACTORS IN THE PROCESS OF ADAPTATION OF A FIRST GRADER TO THE SCHOOL ENVIRONMENT .....</b>	<b>184</b>
Venelin Terziev	
<b>FAMILY'S ROLE IN THE ADAPTATION OF CHILDREN IN SCHOOL .....</b>	<b>194</b>
Venelin Terziev	
<b>EUROPEAN CONVERGENCE IN ECONOMIC GROWTH: THE ROLE OF INNOVATION AND PUBLIC POLICY .....</b>	<b>201</b>
Joana Costa, Eva Pereira, Carlos Rodrigues	
<b>QUALITY OF LIFE AND SOCIO-DEMOGRAPHIC FEATURES OF WOMEN WITH BREAST CANCER PATIENTS.....</b>	<b>209</b>
Diana Tsiring, Irina Ponomareva, Evgeniya Evstafeeva, Marina Mironchenko	
<b>EU TRADE RELATIONS WITHIN THE CONTEXT OF BREXIT (FOCUSING ON EU27 – UNITED KINGDOM RELATIONS) .....</b>	<b>217</b>
Zuzana Kittova, Simona Krivosudska	

<b>COMPARISON OF CHOSEN FINANCIAL DISTRESS PREDICTION MODELS FOR NON-PROFIT ORGANIZATIONS .....</b>	<b>228</b>
Filip Rebetak	
<b>THE DIGITAL TRANSFORMATION OF TRADITIONAL FASHION RETAIL FOR SUSTAINABLE GROWTH.....</b>	<b>236</b>
Sandra Raquel Alves, Humberto Ribeiro, Raja Saravanan	
<b>FOOD MARKET TRENDS: THE CASES OF SPIRULINA AND BEE POLLEN.....</b>	<b>246</b>
Jose Joao Oliveira, Humberto Ribeiro	
<b>DETERMINING THE AMOUNT OF LOST PROFIT IN EXPERT EVIDENCE.....</b>	<b>259</b>
Iveta Sedlakova	
<b>MARKETING RESEARCH AS AN ESSENTIAL PREREQUISITE FOR THE SUCCESS OF A MODERN SOCIETY .....</b>	<b>267</b>
Juraj Kolencik	
<b>FAMILY FIRMS, CORPORATE GOVERNANCE AND QUALITY OF ACCOUNTING INFORMATION: EVIDENCES FROM LITERATURE.....</b>	<b>273</b>
Fernando Nascimento Zatta, Liliane Cristina Segura, Henrique Formigoni, Samuel Mamede	
<b>GAMIFICATION IN MARKETING – A FAD OF CURRENT TIMES? .....</b>	<b>287</b>
Lubica Gajanova	
<b>SOME CRITICAL REMARKS TO THE CONCEPT OF LOVE BRANDS IN CONTEMPORARY CRISIS OF INTERPERSONAL RELATIONS.....</b>	<b>294</b>
Jana Majerova, Margareta Nadanyiova, Lubica Gajanova	
<b>SOCIALLY RESPONSIBLE COMMUNICATION STRATEGY IN THE BANKING SECTOR .....</b>	<b>301</b>
Margareta Nadanyiova	
<b>HOW MOBILE BANKING IN THE DIGITAL ERA CAN RESHAPE THE BANKING LANDSCAPE: A LITERATURE REVIEW .....</b>	<b>310</b>
Maria Cristina Quirici	
<b>DIFFERENCES AND PARTICULARITIES CONNECTED TO RETAIL MARKET CONCENTRATION: THE EVIDENCE FROM CROATIA .....</b>	<b>320</b>
Ivan Kovac	
<b>NEGATIVE CONSEQUENCES OF CREATIVE ACCOUNTING UNDER THE CONDITIONS OF SELECTED EASTERN EUROPEAN ECONOMIES .....</b>	<b>333</b>
Monika Poradova	
<b>DEVELOPMENT OF EXPORT POTENTIAL OF NON-OIL SECTOR OF AZERBAIJAN’S ECONOMY IN THE POST DEVALUATION PERIOD .....</b>	<b>341</b>
Movlud Farzaliyev	

<b>ACCELERATING ECONOMIC DIVERSIFICATION IN AZERBAIJAN: CHALLENGES, SHAPING PROSPECTS .....</b>	<b>352</b>
Mushfig Guliyev	
<b>ADVANCEMENT IN GEOECONOMICS THROUGH TOURISM PROMOTION - INTERNATIONAL BEST PRACTICES OF INFLUENCER MARKETING FOR CORPORATE BRAND MANAGERS AND POLICY MAKERS .....</b>	<b>361</b>
Arpad Papp-Vary, Szabolcs Szolnoki, Endre Beres	
<b>ENTREPRENEURIAL ECOSYSTEMS QUALITY: A MULTI-COUNTRY ANALYSIS BASED ON GEM.....</b>	<b>372</b>
Mariana Pita, Joana Costa	
<b>EDUCATION AS ONE OF THE PHENOMENA OF CONTINUOUS DEVELOPMENT .....</b>	<b>384</b>
Rashad Huseynov, Farhad Mikayilov, Shafiga Mammadova, Elman Ibishov, Rafail Rzayev	
<b>TECHNOLOGICAL RISE HEAVILY IMPACTS E-COMMERCE INDUSTRY.....</b>	<b>394</b>
Daniel Panduric, Igor Klopotan, Tesa Klopotan	
<b>GLOBALIZATION OF THE ECONOMY AND ITS IMPLICATIONS.....</b>	<b>402</b>
Khankishi Khankishiyev	
<b>UPM BIO VERNO: BIODIESEL PRODUCED FROM THE BY-PRODUCT OF THE PULP INDUSTRY AND ITS IMPORTANCE IN GREEN MARKETING AND STRATEGY.....</b>	<b>414</b>
David Vrtana, Anna Krizanova	
<b>DOES THE INSTITUTIONAL ENVIRONMENT AFFECT PERFORMANCE? EVIDENCES FROM DIFERENT COUNTRIES.....</b>	<b>422</b>
Liliane Cristina Segura, Vladimir Fernandes Maciel, Henrique Formigoni, Julian Alexienco Portillo, Daniella Guimaraes Bergamini de Sa	
<b>PROBLEMS OF FINANCIAL RISK MANAGEMENT .....</b>	<b>434</b>
Sarvar Alijan	
<b>PERSISTENCE IN INNOVATION AS AN ENHANCER OF SUSTAINABLE GROWTH .....</b>	<b>440</b>
Joana Costa, Diana Braga	
<b>INTERDEPENDENCE OF CREDIT LENDING TO THE PRIVATE SECTOR AND THE GDP GROWTH RATE IN THE REPUBLIC OF CROATIA.....</b>	<b>451</b>
Marko Akmacic, Andreja Rudancic, Vesna Skare Ozbolt	
<b>TOWARDS AN INCLUSIVE AND INNOVATIVE BIOENERGY DEVELOPMENT THROUGH BRAZILIAN AND NORDIC EXPERIENCE IN BIOFUELS .....</b>	<b>464</b>
Carlo Alessandro Castellaneli, David Nunes Resende	

## TO IT-PROVIDER BUSINESS PROCESSES NETWORK MODEL

**Marina Purgina**

*Novosibirsk State University of Economics and Management (NSUEM),  
Novosibirsk region, Novosibirsk  
Kamenskaya str.56, 630099, Russian Federation  
pur-11@yandex.ru*

**Aleksey Dobrinin**

*Novosibirsk State University of Economics and Management (NSUEM),  
Novosibirsk region, Novosibirsk  
Kamenskaya str.56, 630099, Russian Federation  
serpentfly@mail.ru*

**Roman Koynov**

*Novosibirsk State University of Economics and Management (NSUEM),  
Novosibirsk region, Novosibirsk  
Kamenskaya str.56, 630099, Russian Federation  
koynov\_rs@mail.ru*

### **ABSTRACT**

*The ideas of the project-process approach are widely reflected in information technologies and methods of business management in recent years. At the same time, the work of companies and enterprises is necessarily associated with the continuous optimization of business processes, with pressing issues of increasing the efficiency of enterprises and organizations. A numerical assessment of the effectiveness of business processes can be obtained on the basis of control metrics. The model considered by the authors cannot completely eliminate all the risks, however, it can significantly reduce them due to an improved mechanism for controlling situations at each stage of the process. The proposed normative model of IT-service, which describes the order of work and the necessary resources, can be used to build complex planning systems for the provision of services and synthesis of schedules in various fields of activity. Its main difference from those considered earlier is the inclusion of polymorphism elements through inheritance, which are associated with network components. The proposed technical solutions are suitable for implementation in terms of any modern high-level programming language.*

**Keywords:** *Business process, network model, MSF, ITIL, MOF, Service Transition, polymorphism, guideline exposure, modeling-algorithmic complex, network schedule*

### **1. GENERAL BUSINESS PROCESS MODEL**

Consider a generalized structural model of a business process using the example of a domain (life cycle stages) of Service Transition infrastructure management library – ITIL-v3 [1, 2]. ITIL-v3 library is a collection of «best practices» for managing information technology services. The choice of a service or project management library (ITIL [1, 2], MSF, MOF, RUP, etc.) does not play a fundamental role here and serves only as a starting point, an illustration of the working environment for a certain class of planning tasks, for example, in focused IT-activities. Domain ST (service transformation) describes the transition of the state of a functioning system from one start point to another - the end. The introduction of fundamentally new projects or services can be represented as changes in the accompanying business processes and elements of the IT- infrastructure relative to some empty (or missing) set of elements.



Such a need can be dictated by various reasons, the most compelling of which is the need for continuous optimization of business processes in a competitive environment and improving the quality of services (products) [3]. There is always a way to improve in a certain way what has been done and worked well before. Replacing software, updating infrastructure, designing and implementing new technologies, developing new software are typical examples of transforming any IT-systems (business processes and services) into a new state. Each transition is accompanied by time costs, input or output of assets, financial costs, the needs of specific performers and other non-trivial tasks. To assess the quality or effectiveness of business processes, appropriate metrics are needed [4]. Thus, there is a final set of works between the two points, activities that need to be completed for a certain period of time, agreed with the project participants. In fact, to describe the list of works and operations needed to transfer the state of the system from the current to the final, one or more network diagrams (directional graph) of any kind can be used. The start and end points of the network diagram can be associated with the states of the system, or with the beginning and end of a specific regulatory process in the ITIL-v3 domain. The Service Transition stage describes seven regulatory processes that must be implemented during a state transition:

1. Change Management (ChM) - change management.
2. Service asset and Configuration management (SAaCM) - asset and configuration management.
3. Knowledge management - knowledge management.
4. Transition Planning and Support - conversion planning and support.
5. Release and Deployment management - release and deployment management.
6. Service validation and Testing - validation and testing.
7. Evaluation - assessment.

Consider the basic model of a business-process in which a procedural or network description of the performed actions, work is allowed. The basic model is used at the initial stage; in practice, it can be decomposed to the required level, which will ultimately provide complete information systems for planning assessment and support of business processes (Figure 1).

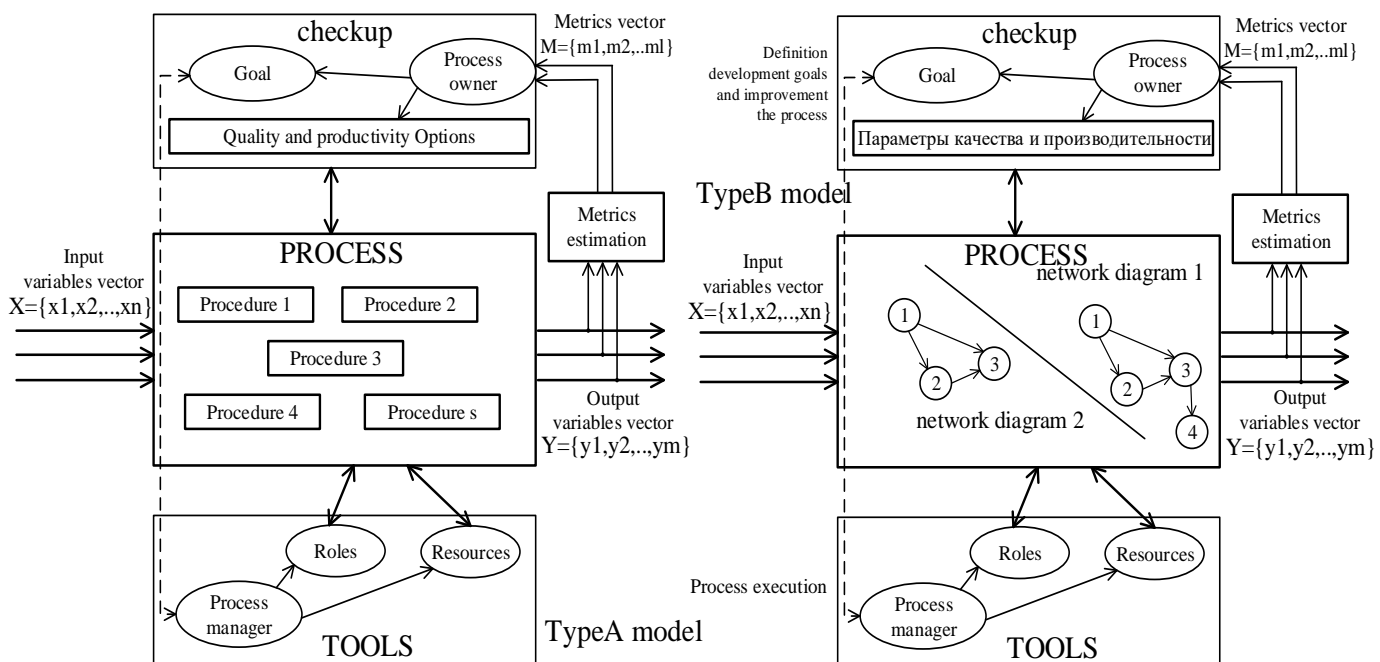

Figure 1: Procedural and (or) network model of a business process

As the main element of the proposed process model (type B) used in this work, we consider a directional graph (network diagram), of an arbitrary form, in which nodes denote certain stages (events) and arcs - operations (actions, works). With nodes and arcs, information of various kinds is identified. This approach, ultimately, allows you to create dynamic models with a constantly changing set, composition of metrics and mechanisms for their evaluation. The process owner provides a business vision of the main goals, objectives and process metrics. The process manager ensures the flow of the process in a form consistent with the business.

## 2. NETWORK MODEL OF A BUSINESS PROCESS WITH ELEMENTS OF POLYMORPHISM

In fact, any business process can be described periodically by repeating (for operational activities) or a unique set (project activity) of actions, procedures. For such a description, a network structure (directional graph) of an arbitrary kind is well suited, created on the basis of a model of time (duration) of work, resources, and associated data of arbitrary nature. The general idea of the process is supplemented by individual elements, resources and roles that are necessary for its full functioning. A possible special case of the representation of such a model is shown in Figure 2.

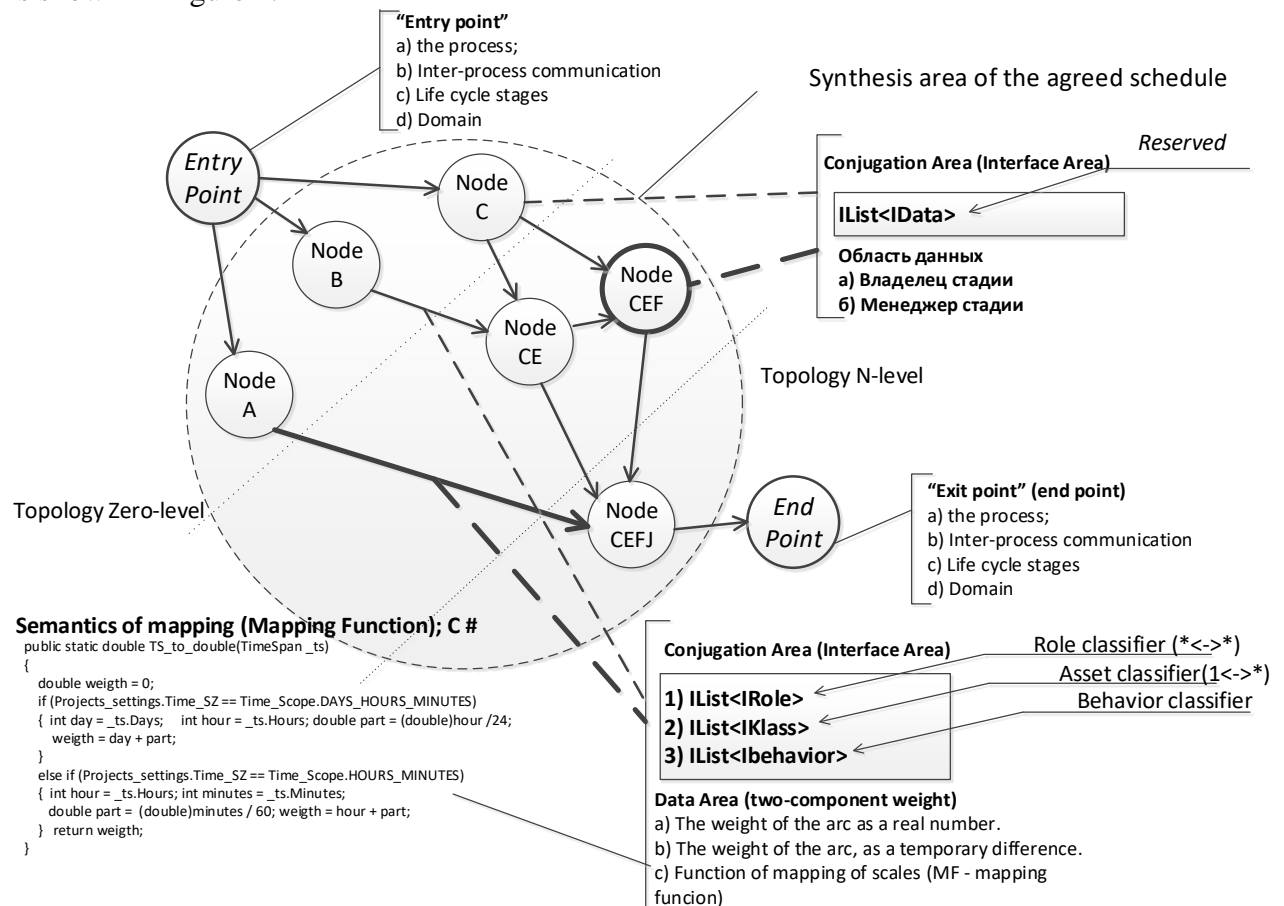

Figure 2: An example of a network model of a business process with elements of polymorphism

In the presented example of the model, a two-component weight is associated with each arc of the graph, which describes the time difference and the corresponding real number, calculated using the function matching the time difference (C # TimeSpan structure), an equivalent real number(1):

$$Number(weight) = F(TimeSpan) = Day + \frac{Hour}{24} + \frac{Minute}{60} \quad (1)$$

The arcs and vertices of the network diagram are associated with specific data of various nature, such as two-component weight, the owner and stage manager, and the corresponding interfaces that allow you to dynamically bind entities that implement them.

The composition, structure and order of actions performed when changing (transforming) a service depends on the subject area in which the business or IT-department operates. Obviously, the course of the main processes will be quite different for companies engaged in the development and sale of software in the market and companies involved in technical support and user support. Do not underestimate the role of owners and managers of business processes at various stages of the life cycle. The process owner is interested in maximizing profits, minimizing all costs and uncompromising, rigorous optimization of any activity. The process owner determines the goals, objectives, as well as metrics by which all processes will be evaluated. The process manager is responsible for achieving the goals set by the owner, provides processes with assets and resources to achieve the specified metrics.

Consider the technological scheme of the elements of the stage of transformation (implementation) of the service life-cycle services for ITIL, MOF (Microsoft Operations Framework)-notations. The proposed scheme reflects the individual stages of the life cycle, which are connected in a single logical sequence. Formally, the implementation is carried out gradually, at the initial stage, the planning and testing of release components with updating of knowledge and configuration database (CMDB) is carried out, at the final stage the same thing happens after the direct implementation (Figure 3).

*Figure following on the next page*

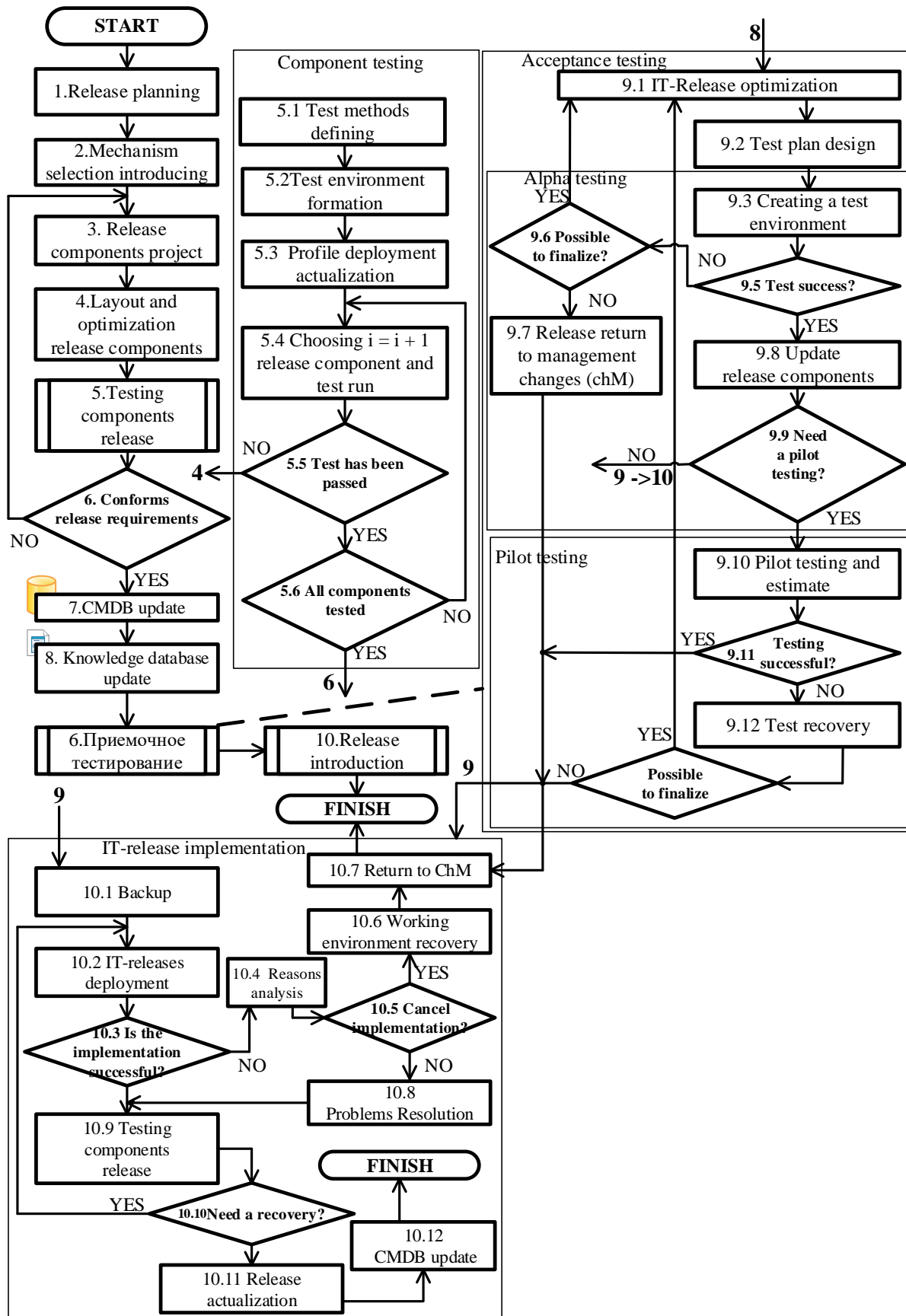

Figure 3: An enlarged view of the stage of transformation of service implementation using the example of ITIL, MOF

The normative representation of the activity shown in Figure 3, suitable for organizations providing consulting services for project management and typical business processes in the field of information technology. The modern approach adopted in business is to use integrated packages [5,6] to improve the efficiency of business processes in general. The construction of large integrated planning systems, support of business processes can be obtained only due to the additional flexibility associated with the ability to bind data of various nature.

### 3. CONCLUSION

The business process model presented in the article is based on an incomplete model of the software life cycle [7] and is used in the model-algorithmic complex (MAC) of activity planning and construction of schedules on graphs [8]. As practice has shown, the key advantage of the proposed business process model in comparison with rigidly fixed models is the flexibility and wide coverage of a wide range of diverse tasks for planning, creating and further supporting business processes.

### LITERATURE:

1. OGC-ITIL V3-2 Service Transition, TSO. - 2007.
2. Rob England. Mastering ITIL / Rob England; Per. from English - M.: Livebook, 2011 .-200 p. ISBN 978-5-904584-13-9.
3. Elena Vetluzhskikh. Strategic map, systems approach and KPI. Tools for managers / Elena Vetluzhskikh - M.: Alpina Business Books, 2008. -208 p.
4. Metrics for managing IT services / Peter Brooks; trans. from English - M.: Alpina Business Books, 2008.-208 p.
5. Zagidullin R. R. Management of machine-building production using MES, APS, ERP systems. - Stary Oskol: TNT, 2011. - 372 pp. - ISBN 978-5-94178-272-7.
6. Bell, Steve. ERP, CRM, PLM working together // Lean Enterprise Systems.— N.Y.: McGraw-Hill, 2006. — P.242-296. - 436 p. - ISBN 978-0-471-67784-0
7. Dobrynin A. S. Model of the incomplete software life cycle / A. S. Dobrynin, R. S. Koynov, S. M. Kulakov // Vestnik ASTU. Series: Management, Computing and Informatics. - 2015. - No. 2. - S. 65-69. - Bibliography: p. 69 (9 titles).
8. Certificate on state registration of computer programs No. 2014613280 Russian Federation. Schedule program in design and process activities and service management / Dobrynin A. S., Koynov R. S., Kulakov S. M., Zimin V. V.; copyright holder Dobrynin A. S. - No. 2014610775; declared 02/06/2014; register. 03/21/2014. - [1] p.

# FUNCTIONAL STRUCTURING OF AN ADAPTIVE IT-PROCESS MANAGEMENT SYSTEM

**Marina Purgina**

*Novosibirsk State University of Economics and Management (NSUEM),  
Novosibirsk region, Novosibirsk  
Kanemskaja str.56, 630099, Russian Federation  
pur-11@yandex.ru*

## **ABSTRACT**

*One of the key stages of life cycle, according ITIL-3, is the stage of IT-services continuous improvement, which goal is to adapt IT-processes to changing conditions for their implementation. The IT-provider processes are the most dynamic asset, which modification can help an IT-service provider quickly adapt to changing external and internal conditions. The IT-provider maintains and /or improves its competitiveness in the market for the production and delivery of IT-services by increasing the efficiency of IT-processes. In order to develop and concretize the representations of ITIL-3, the author proposed a functional structure of the adaptive three-level IT-process management system, recommended for use in relatively stable external and internal operating conditions. Where the first-level management system solves the problems of implementing the stages of IT-services life cycle with a given efficiency, the second-level system performs situational optimization (improvement) of IT-processes (ensures the competitiveness of supplier processes services), and the third-level system is the coordinator of subordinate systems.*

**Keywords:** *parametric model, multi-agent active element, theory of organizational systems, multiple behavior strategies, objective function, set of specific competencies, economic behavior, agent*

## **1. MANAGEMENT SYSTEM FOR THE PRODUCTION AND PROVISION OF IT-SERVICES**

In rapidly changing market requirements for IT-services, IT-processes must be constantly changed in order to ensure the competitiveness of IT-service provider. IT-service, from the consumer's point of view, is an information technology tool used and managed by the consumer/client to produce the necessary value in the field of activity that the consumer carries out, and from the point of view of IT-provider, it is an IT-asset system designed and operated by IT-provider [1]. We also can say that IT-service management is the development and application of specialized organizational mechanisms for the functioning and management of IT-assets in order to formulate the properties of services needed by the consumer. An important area related to management optimization, including IT-services, is adaptive systems. Adaptation in science, in a broad sense, is the process of system self-transformation, when certain external and internal conditions of its functioning change. Novikov D.A. in [5] considers the concept of adaptability in a broad sense as purposeful adaptability, self-organization, or homeostasis in the conditions of dynamic functioning and other systems that are changing in an uncontrolled way.

With the aim of developing and concretizing the representations of ITIL-3 in [2], the author of this article proposed a functional structure of adaptive system for managing the production and provision of IT-services (MS PPM), recommended for use in relatively stable external and internal operating conditions, a fragment of which is shown in Figure 1.

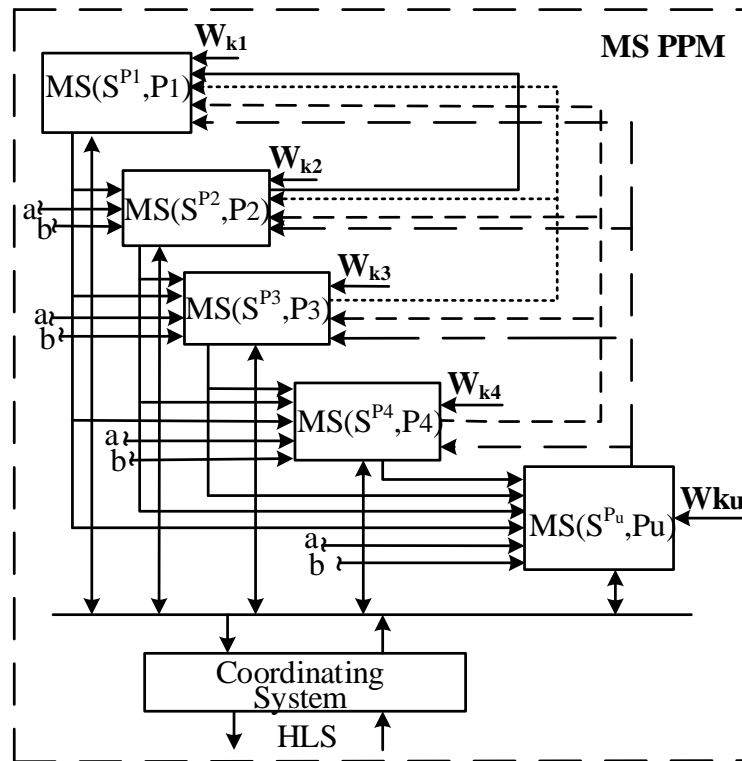

Figure 1: The structure of the management system for the production and provision of IT-services

The compound elements of the structure above are management systems  $(S^{P1}(t), P_1)$ ,  $(S^{P2}(t), P_2)$ ,  $(S^{P3}(t), P_3)$ ,  $(S^{P4}(t), P_4)$ ,  $(S^{Pu}(t), P_u)$  of stages of IT-service life cycle, which management objects are the corresponding stage-by-stage full-scale processes  $P_1, P_2, P_3, P_4, P_u$  that implement normative models of processes  $P^*_1, P^*_2, P^*_3, P^*_4, P^*_u$ : stage 1 - strategy development, 2 - design, 3 - implementation, 4 - operation, u- utilization,  $S^{Pk}$  with  $k \in \{1, 2, 3, 4, u\}$  - a set of services to be processed by the corresponding processes, HLS – high-level systems.

To maintain and increase competitiveness in market conditions, it is not enough for a service provider to improve the efficiency of IT-processes relative to the achieved level (this task is solved by the management system, shown in Figure 1), but to do it no worse than competitors. Purposeful optimization of IT-processes in accordance with changing external and internal operating conditions in an uncontrolled manner requires the inclusion in the control system of a special subsystem that implements the process optimization function. An uncontrolled external effect leads, and internal is manifested in efficiency decrease of the process and requires, as a rule, the identification of this effect, the development of an optimizing solution and the corresponding change in the process.

## 2. FUNCTIONAL STRUCTURE OF THE MANAGEMENT SYSTEM AND CONTINUOUS OPTIMIZATION OF PRODUCTION PROCESSES AND THE PROVISION OF IT-SERVICES

The proposed structure was obtained as a result of the inclusion in the functional structure of the management system and the production and provision of IT-services (Figure 1) the IT-process optimization system (SOP). The result of this inclusion is a three-level hierarchical system, shown in Figure 2.

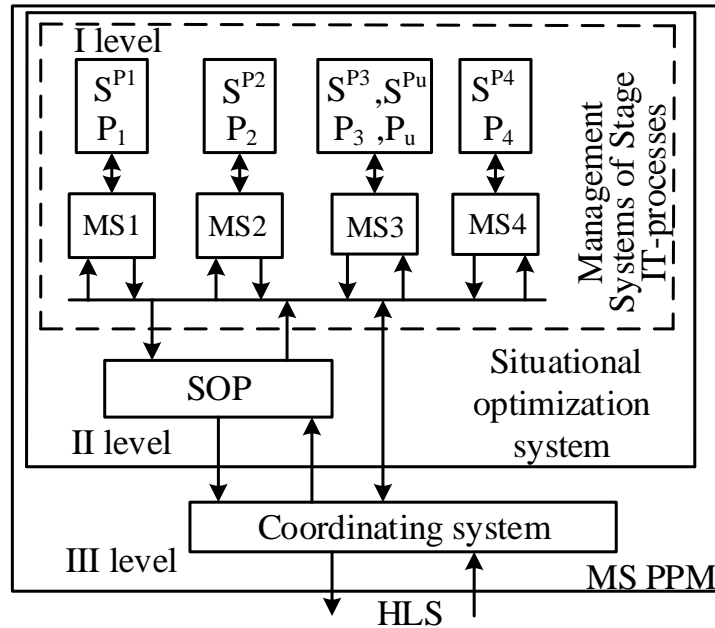

Figure 2: General view of the production management and IT-services management system

The first-level system manages the in-situ processes  $P_1, P_2, P_3, P_4, P_u$ , which cover the development and support of the use of IT-services by consumers. The optimization system belongs to the second level and implements changes in IT-processes, providing the level of their efficiency that guarantees the competitiveness of the services of the IT-provider. At the same time, it solves the following tasks:

1. Monitoring and analysis of processes and mechanisms, including:

- best practices of competitors and achievements in IT-field which have led or may lead to a decrease in the competitiveness of provider services;
- manifestations of a decrease in the efficiency of IT-processes relative to the achieved level.

2. Development of optimization solutions for:

- introducing best practices and achievements of the IT-sector into process activities;
- restoration and increase of the lost efficiency of IT processes.
- determining the planned profitability of projects to optimize IT-processes.

3. Ranking of optimization projects.

4. Initiation and control of the implementation of optimization projects.

5. Monitoring the actual effectiveness of initiated projects and streamlined processes.

6. Monitoring the effectiveness of the system for optimizing IT-processes.

Figure 3 shows the functional structure of a three-level system for managing a separate IT-process, which is based on well-known developments in the field of adaptive control systems [3,4]. The figure illustrates the order of interaction and the functioning mechanisms of the control systems of the first and second level.

*Accepted designations:*

$P_{kl}^*$  - current normative model of the  $l$ -th process of stage  $k$ ;  $P_k = \{P_{kl} \mid l \in L_k\}$  - in situ processes of stage  $k$ ;  $W_{nk} (CO)$ ,  $W_k (CO)$ ,  $W_k (MS)$  - uncontrolled and controlled external influences on the control object and management system;  $q_{kl}^*$ ,  $\{\mu_{kl}^{n*} \mid n \in N_{kl}\}$ ,  $\gamma_{kl}^*$ ,  $z_{kl}^*$  -



planned values of a comprehensive indicator of the process efficiency- client satisfaction and  $P_{kl}$ -process cost;  $\{\sigma_{kl}^*\}$ - established controlling mechanisms of the  $l$ -th process;  $\{\hat{q}_{kl}, \{\hat{\mu}_{kl}^n | n \in N_{kl}\}, \hat{\gamma}_{kl}\}$ ,  $\hat{z}_{kl}$ - estimates of the actual values of the  $P_{kl}$ -process efficiency indicators, and process costs;  $\{q_{kl}\}, \{\{\mu_{kl}^n | n \in N_{kl}\}, \{\gamma_{kl}\}, z_{kl}, \{\sigma_{kl}\}$ - the set of process efficiency indicators used by the first-level of management and their values;  $RFC\{\{q_{kl}^i\}, \{\gamma_{kl}^i\}, z_{kl}^i, P_{kl}^i, \{\{\mu_{kl}^{ni} | n \in N_{kl}^i\}\}, \{\sigma_{kl}^i\}$ - second-level request of implementation modification system to update process performance indicators and their values;  $P_{kl}^{i*}$  - updated process of implementation modification;  $\{\{q_{kl}^i\}, \{\gamma_{kl}^i\}, z_{kl}^i, \{\mu_{kl}^{ni} | n \in N_{kl}^i\}\}, \{\sigma_{kl}^i\}$ - an updated set of process performance indicators and their values, managing mechanisms with appropriate measurement and support tools; SG, RR - set goals, regulatory resources; AG, UR - achieved goals, used resources.

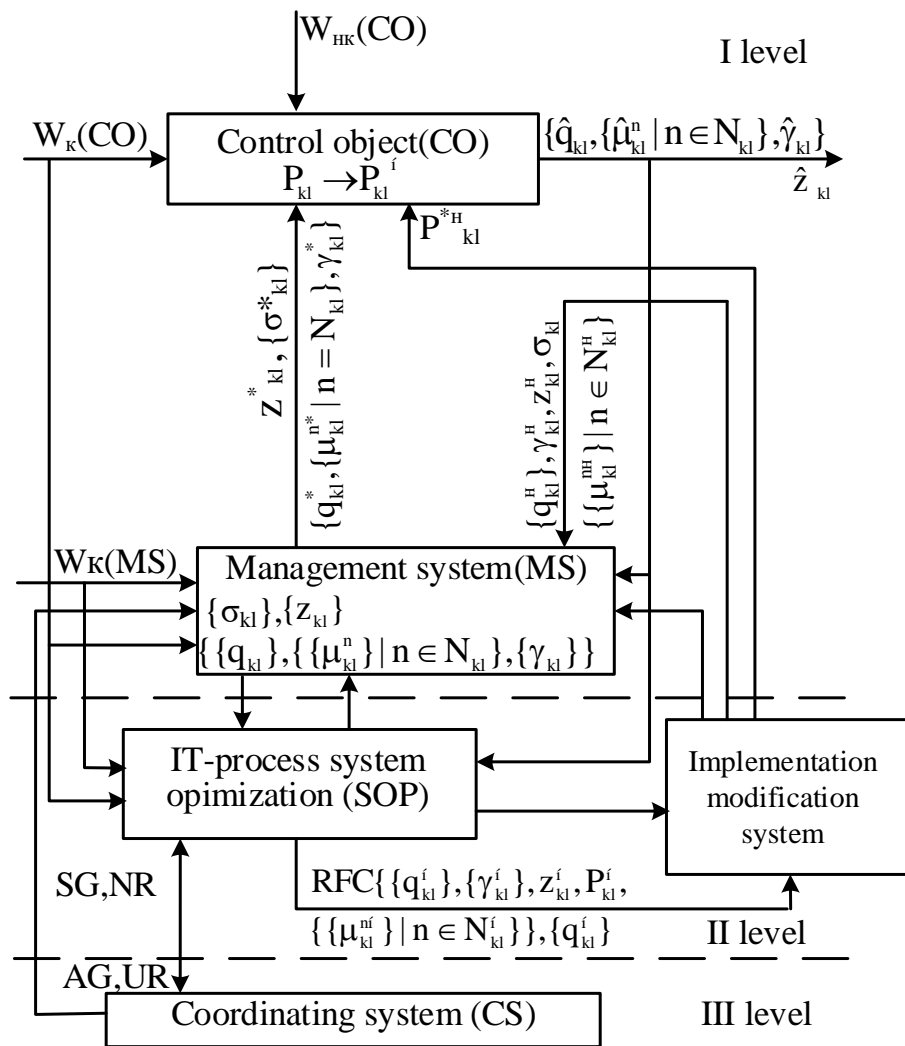

Figure 3: Specification of the functional structure of the system management and continuous optimization of a separate IT-process ( $P_{kl}$ )

CG, NR– control system goals, normative resources  
 AG, UR-achieved goals, used resources

Let us list some management mechanisms used at the first management level: formation planned values mechanisms for the efficiency and costs indicators; measuring and evaluating mechanisms of the actual values of efficiency and costs indicators; resources distributing a mechanism between the processes stages and between stages, etc.

In contrast to the second level of management, which aim is to maintain and improve the IT-processes competitiveness, the first-level of management solves the problem of ensuring the nominal implementation of the service life cycle processes with the achievement of the set values of efficiency and cost indicators. Let us consider the formulation and decomposition of the main problem solved at the first-level of the management system.

### 3. THE PROBLEM STATEMENT, SOLVED BY THE FIRST-LEVEL OF MANAGEMENT

The goal of the first-level of the IT-process management system is to maintain the effectiveness of each IT-process at a given level, determined by the planned values of efficiency indicators  $\{q_{kl}^*, \{\mu_{kl}^{n*} | n = N_{kl}\}, \gamma_{kl}^*\}$  and planned costs-  $z_{kl}^*$ . Let  $\{P_k | k \in K\}$ ,  $K = \{1, 2, 3, 4, u\}$  be the set of stages in the life cycle of an IT-service. Let also be  $P_k = \{P_{kl} | l \in L_k\}$ , where  $P_{kl}$  is the l-process of the stage, and  $\{\gamma_{kl}^m(t) | m \in M\}$  is the satisfaction of users (M -is the set of users) of services by the functioning of the  $P_{kl}$ -process. We denote  $\gamma_{kl}(t) = \gamma_{kl}(\gamma_{kl}^1(t), \dots, \gamma_{kl}^{M_{kl}}(t))$  - the resulting user satisfaction with the process  $P_{kl}$  at time t, and  $\gamma_k(t) = \gamma_k(\gamma_{kl}(t), \dots, \gamma_{kl|L_k|}(t))$  - the total user satisfaction with the stage processes. Let  $\gamma$  be the user satisfaction with the LSC (life-service cycle) processes (the integrated efficiency of the processes of the IT-provider), which is a certain function  $F_1$  defined on the total user satisfaction with the stage processes, where  $k \in K$ :  $\gamma(t) = F_1(\gamma_1(t), \dots, \gamma_u(t))$ . (1)

Let also  $\mu_{kl}^n(t)$ ,  $n \in N_{kl}$  be the measured and calculated by IT-service provider process efficiency indicators  $P_{kl}$ ,  $\mu_{kl}(t) = \mu_{kl}(\mu_{kl}^1(t), \dots, \mu_{kl}^{N_{kl}}(t))$  - the resulting measured process efficiency  $P_{kl}$ , and  $\mu_k(t) = \mu_k(\mu_{kl}(t), \dots, \mu_{kl|L_k|}(t))$  -the total measured process efficiency of the  $P_{kl}$ -stage. Define as a complex measured indicator - $\mu$  some function - $F_2$ , defined on the processes efficiency, where  $P_k$ , где  $k \in K$ :  $\mu(t) = F_2(\mu_1(t), \dots, \mu_u(t))$ . (2)

We denote  $q_{kl} = q_{kl}(\gamma_{kl}, \mu_{kl})$ ,  $q_k = q_k(\gamma_k, \mu_k)$ ,  $q = q(\gamma, \mu)$  the efficiency indicators, respectively, of the l -process of the k-stage  $P_k$ -processes of a stage  $P_k$  and processes of all stages.

An equally important indicator of the effectiveness of IT-processes is the cost of their implementation. Let  $z_{kl}(t)$  be the costs of the operation of the process  $P_{kl}$  at time t. Then the costs of the  $P_k$ -stage processes and the costs of the service life cycle processes will be:

$$z_k(t) = \sum_{l \in L_k} z_{kl}(t), \quad (3)$$

$$z(t) = \sum_{k \in K} \sum_{l \in L_k} z_{kl}(t). \quad (4)$$

The costs of the processes and their effectiveness are related quantities. Greater process efficiency requires, as a rule, high costs. At the same time, the goal of the first-level system is to achieve the efficiency of IT-processes agreed with the consumer. The efficiency of processes above the required level is inappropriate, since investment in the processes will not be returned. This means that if the quality of the processes has reached or exceeded the required level, then the costs of the processes should be reduced, and otherwise, invest in the processes. Let  $(0, T)$  be some planning period. We define as the criterion  $Q$  the optimality of the problem solved by the system of the first-level, the following functional:

$$Q = \int_0^T (q(t) - q^*)^2 dt. \quad (5)$$

Let denote  $z^*$  as the marginal cost of creating and running processes that an IT-provider can afford. Then, taking into account (3) and (4), the main limitation of the described problem can be represented as follows:

$$z(0, T) = \sum_{k \in K} \sum_{l \in L_k} \int_0^T z_{kl}(t) dt \leq z^*. \quad (6)$$

Given the above problem solved by the system of the first-level of management, can be formulated as follows.

**Given:**

1. An operating system for managing the production and provision of IT services, Figure 1, which includes systems for managing the stages of the service life cycle of a MS( $S^{P_1}(t)$ ),  $P_1$ ); MS ( $S^{P_2}(t)$ ),  $P_2$ ), MS ( $S^{P_3}(t)$ ),  $P_3$ ), MS ( $S^{P_4}(t)$ ),  $P_4$ ), MS ( $S^{P_u}(t)$ ),  $P_u$ ).
2.  $P_1, P_2, P_3, P_4, P_u$  – IT-processes with specified efficiency indicators  $\{q_{kl}\}, \{\{\mu_{kl}\} | n \in N_{kl}\}, \{\gamma_{kl}\}, \{z_{kl}\}\}, (k \in K, l \in L_k)$  and sets of possible values of indicators.
3. The set of process management mechanisms  $\{q_{kl}\}, (k \in K, l \in L_k)$ .
4. The planned period  $(0, T)$  of the functioning of the control system.
5. Planned values of  $q_{kl}^*, q_k^*, q^*$ , ( $k \in K, l \in L_k$ ), efficiency indicators of IT-processes, standard costs for processes  $z_{kl}^n$  and marginal costs  $z^*$  of a service provider for IT-processes.

**Required:**

to provide management over the planned period time  $(0, T)$  by  $P_{kl}$ -processes using mechanisms  $\{q_{kl}\}, (k \in K, l \in L_k)$ , which minimizes criterion (5) and ensures that constraint (6) is satisfied.

#### 4. DECOMPOSITION OF THE TASK OF OPTIMIZING DESIGN AND OPERATIONAL PROCESSES

Decomposition consists in representing the original problem in the form of many other tasks that can be solved, in determining the sequence and procedures for solving these problems.

The simplest decomposition scheme of the original problem with criterion (5) and constraint (6) consists in decomposing it into a set of tasks for each process  $P_{kl}$ , ( $k \in K, l \in L_k$ ). By analogy with (5), we define the following criterion  $Q_{kl}$  for the control problem of an individual process  $P_{kl}$ :

$$Q_{kl} = \int_0^T (q_{kl}(t) - q_{kl}^*)^2 dt. \quad (7)$$

Replace restriction (6) with the set of constraints for each process  $P_{kl}$  as follows. Let  $z_{kl}^n$  be the standard costs of the current system for the  $P_{kl}$ -process in the planning period. Then consider:

$$z_{kl}^* = \frac{z^* z_{kl}^n}{\sum_{k \in K} \sum_{l \in L_k} z_{kl}^n}. \quad (8)$$

Where  $z_{kl}^*$  is an estimate of the marginal cost that a provider of the  $P_{kl}$  -process can afford. Now, the original task (5,6) can be represented as a set of tasks (9,10):

$$Q_{kl} = \int_0^T (q_{kl}(t) - q_{kl}^*)^2 dt, \quad (9)$$

$$\int_0^T z_{kl}(t) dt \leq z_{kl}^*, \quad \forall k \in K, l \in L_k. \quad (10)$$

The problems optima (9,10), obtained as a result of decomposition cannot exceed the optimal solution of the problem (5,6). It is possible to improve these optima by defining a special procedure for solving these problems and taking into account the results of already solved problems for finding optima that are still unsolved. Let  $\alpha(P_{kl})$  be an indicator of the degree of importance of the  $P_{kl}$ -process for the consumer, and

$$\sum_{k \in K} \sum_{l \in L_k} \alpha(P_{kl}) = 1. \quad (11)$$

The indicator  $\alpha(P_{kl})$  reflects not only the degree of impact of the  $P_{kl}$ -process on the results of consumer activity, but also the degree of urgency (importance) of restoring the effective operation of the  $P_{kl}$  process. We determine the order of solving problems (9, 10) in accordance with the decreasing values of  $\alpha(P_{kl})$ . This will primarily allow the allocation of resources to more important processes for the consumer. We formulate a problem that will be solved at the n-step. Let  $KxL = \{(k,l) | k \in K, l \in L_k\}$ .

We denote  $KxLn-1$  as the set of indices of problems solved up to the (n-1)-step inclusively, and  $\overline{KxLn-1} = KxL \setminus KxLn-1$ , indices of unresolved problems. Let  $z_n^*$  be the marginal cost for a set of unresolved problems:

$$z_n^* = z^* - \sum_{j=1}^{n-1} z_j^*. \quad (12)$$

Note that the optimal solution to each problem does not necessarily require the use of all allocated resources, that is, in the general case  $z_j^* \geq z_j^{*opt}$ . Thus, (12) should be replaced by following:

$$z_n^* = z^* - \sum_{j=1}^{n-1} z_j^{*opt}. \quad (13)$$

Denote  $z_{kl}^{*n}$  the marginal cost for the problem to be solved at the n-step. Let consider

$$z_{kl}^{*n} = \frac{z_n^* z_{kl}^d}{\sum_{(k,l) \in K \times L_{n-1}} z_{kl}^d} \quad (14)$$

Then at the n-step it is necessary to solve the problem:

$$Q_{kl} = \int_0^T (q_{kl}(t) - q_{kl}^*)^2 dt, \\ \int_0^T z_{kl}(t) dt \leq z_{kl}^{*n}, \quad (k,l) \in \overline{K \times L}^n. \quad (15)$$

Resources, not used in the implementation of the optimal solution,  $z_j^* \geq z_j^{*opt}$  could be used not for optimization of processes that have not yet been improved, as provided in (13), but for additional optimization of already modified processes. This will require re-solving individual tasks.

## 5. CONCLUSION

The development of problem solving procedures (9,10) for the main processes of the stages of IT-service life cycle shows further interest. These procedures can be based on the features of optimized processes, as well as management mechanisms developed in the framework of the theory of management organizational systems [5,6]. Another area of research is related to the formulation and development of solving tasks procedures for of the second level of management (optimization problem), Figure 3.

**ACKNOWLEDGEMENT:** *A computer simulation of the IT-processes optimizing task solution was carried out. Modeling showed that using a four-score scale of efficiency indicators and modernization costs of \$ 5,000 is possible to increase the efficiency of the operation stage by 25% by investing in improving two efficiency indicators.*

## LITERATURE:

1. OGC-ITIL V3-6 - Service Lifecycle - Introduction ITIL TSO 2007. -173p.
2. V.V. Zimin, S.M. Kulakov, A.V. Zimin / On the structuring of the management system of the activity of the IT provider // Management Systems and Information Technologies, No. 2.1 (48), 2012. - P. 198-202.
3. Denisova L. A. Systems of automated control: textbook. allowance / L. A. Denisova, E. M. Raskin. - Omsk: Publishing House of OmSTU, 2010. - 80 p.
4. Antonov V.N., Terekhov V. A. Tyukin I.Yu. Adaptive management in technical systems: Textbook. allowance. - St. Petersburg: Publishing House of St. Petersburg University, 2001. - 244p. p.
5. NOVIKOV D.A. Theory of management of organizational systems. M.: MPSI, 2005. - 584 p.
6. Control mechanisms: textbook / edited by D.A. NOVIKOV. -M.: LENAND, 2011. -192 p.

# RESEARCH OF THE PHENOMENON OF IMPLICIT KNOWLEDGE, ITS STRUCTURING AND MANAGEMENT IN THE DIGITAL ECONOMY BASED ON TRUST

**Petr Pashkov**

*Novosibirsk State University of Economics and Management, Russia  
ppm@cn.ru*

**Vasily Soloviev**

*Novosibirsk State University of Economics and Management, Russia  
Solvi2@bk.ru*

## **ABSTRACT**

*It is the value of explicit and implicit knowledge, its structuring and management in the modern economy in the process of its digital transformation that determines the relevance and importance of the subject area of research described in the article. Detection, preservation, transformation, exchange and management of implicit knowledge with an adequate level of trust in the digital enterprise, which is a key subject of the digital economy, all this has defined and shall define the development of society, including the economic one. One of the key problems in the digitalization of the implicit knowledge and the widespread use of modern management systems for them in the digital enterprise are the limitations associated with the trust in the generated and circulating knowledge and the use of adequate models and tools to transform implicit (non-formalized) knowledge, which stays in a hidden form, into explicit (formalized) knowledge desired by users and corporate information systems. What is important here is the trust in such knowledge obtained as a result of a transformation. The purpose of this study is to update the models and tools for the transformation of implicit knowledge into the format of an explicit and trustworthy one, and aimed at solving the problem of assimilating and communicating such knowledge in the context of a digital enterprise, and this allows to distinguish the approach proposed by the authors in conceptualizing the trust in knowledge among the knowledge known and used in modern practice. This will allow to configure and to implement a new approach in solving the problem of converting knowledge into a trust-based format enabling users and an entire organization to acquire new competencies that are in demand at a digital enterprise and the digital economy as a whole. An expediency of the proposed approach to converting the implicit knowledge into a format of an explicit, credible knowledge through the proposed conceptual framework for identifying implicit knowledge has been shown.*

**Keywords:** *approach, digital enterprise, implicit knowledge, transformation, trust*

## **1. INTRODUCTION**

Production (generation), preservation and structuring, dissemination and transfer of knowledge from one generation to another, all this has determined the development of society, including the economic one. All this is associated with an impact of a number of fundamental factors, including the information (digital) revolution and the formation of a new economy, including a digital one that is also built on knowledge.

As for knowledge itself, the following forms of knowledge manifestation are of interest in the context of the subject area of research:

- obvious or formalized /codified/ explicit knowledge: innovations, patents, licenses, knowledge assets, procedures, business process description, business models, policies, missions, Intranet, Extranet, corporate websites, regulations, guidelines, instructions, memos, transactions, consulting, etc.;

- implicit or informal / tacit knowledge: skills, know-how, values, beliefs, competencies, intuition, opinions, practices, understanding, attitudes, etc.

In a number of researches on a problem of revealing and application of the implicit knowledge, a model of creation of new knowledge takes an extraordinary place which is a model of a knowledge spiral (the SECI model by I. Nonaka and H. Takeuchi), according to which new knowledge shall be created (designed) through an interaction of implicit knowledge and explicit knowledge [9]. This model is a result of research by these authors concerning an effective solution of the problem of developing and launching the bread-baking technology at home, where the so-called “kinaesthetic” knowledge was needed, which the developers could get only by working directly with the bakers and studying the sensations they received from the real process of kneading the dough.

All types of knowledge: implicit, explicit, as well as the trust in them as artefacts with credibility and reliability and produced through adequate and valid tools, and determines the authority and recognition of scientific research, its influence results of society, government, business, education and other factors. The work of the American scientists from the Notre Dame and Purdue Universities [14] presents a thorough analysis of well-known studies published between 1967 and 1994, which show the importance of trust in relation to such areas as communication, leadership, goal management, negotiation, game theory, performance evaluation, team relations, project management.

The study of the trust concept, despite the interest shown by a number of researchers from different scientific fields, has been retaining its problematic status for the following reasons: ambiguity of interpretation of the trust itself, a lack of correlation between the trust, source (subject) and tools of the trust object production, metrics of its evaluation, knowledge result, its form (explicit or implicit), address and type of visualization of knowledge itself and other conditions.

Hence, the subject area of research within the framework of the presented issues and its relevance can be defined as the concept of the phenomenon of the implicit knowledge, its structuring and management in the digital economy on the basis of trust.

All these factors create prerequisites for research aimed at updating models and tools for the transformation of the implicit knowledge into a format of explicit, trustworthy, and aimed at solving the problem of assimilating and communicating such knowledge in the context of the digital economy.

To achieve this goal, the following tasks have to be formulated:

- identifying the role of the implicit knowledge in the process of digital economy formation;
- research of models and tools for detecting the implicit knowledge;
- analysis of the problem of trust in the implicit knowledge in the context of digital transformation of enterprises;
- proposing a concept for ensuring confidence in the process of identifying the implicit knowledge in the process of a digital transformation of enterprises.

## **2. IMPLICIT KNOWLEDGE IN THE DEVELOPMENT OF THE DIGITAL ECONOMY**

For the new economy, called digital and built on knowledge, the defining factors are as follows:

- dynamic generation, updating and continuous replenishment of knowledge;
- a new market segment that has emerged in the context of an intellectualization of knowledge products and services, such as innovations, patents, licenses, knowledge assets, business models, transactions, consulting, etc.

In the author's understanding, the generation and circulation of the implicit knowledge are processes of intellectual activity of practitioners, and hence, it is preferable that models and tools for the digital transformation of the implicit knowledge should provide users with increased confidence in the processes of assimilating and communicating such knowledge in the context of the digital economy. All this creates prerequisites for a need for research to update models and tools for the transformation of the implicit knowledge into a format of an explicit one, and that will allow such reformatted knowledge to communicate, configure and manage, and thus to master users and organizations as a whole, applying new competences demanded in the digital economy.

As a methodological basis for the study of the subject area, the authors have selected system, process and competence approaches, as well as modeling and results of studying various aspects of the identification and transformation of the implicit knowledge, presented in the works [Taylor F. W., 1991; Simon H., 1973; Polanyi M., 1962; Nonaka I., Takeuchi H., 1995; Bateson G., 1979, et al.]. All this will make it possible to configure digital tools and implement a new approach to solving the problem of converting implicit knowledge into a format of a trust-based one, enabling users and the organization as a whole to acquire new competencies to manage such knowledge demanded in the digital economy.

The English physicist, chemist and philosopher M. Polanyi has argued that the explicit knowledge is transmitted in words and numbers, is just sort of an iceberg tip of the acquired individual knowledge, i.e. it is only that part of total knowledge, which is formalized in turn, the rest in the form of implicit knowledge which is acquired by an individual in the process of gaining new knowledge through actively producing artifacts, organizing and systematization of its practice, skills, etc. [12]. The implicit knowledge that exists in an organization, which is estimated to be between 40 and 80%, cannot be easily detected, extracted, or transmitted.

A more meaningful approach to the description of the implicit knowledge, its identification, transformation and structuring is shown by the Japanese researchers and practitioners I. Nonaka and H. Takeuchi, who have expressed the position that the non-formalized (implicit) knowledge can be identified mainly in the practices, skills, know-how, etc. of the individual [9]. This undoubtedly makes it difficult to formalize such knowledge, as well as to transfer and use it, for example, by other employees of the organization (internal consumption) or partners (external consumption). Here we can ascertain that in such a context, the implicit knowledge is directly related to the activities and skills of a certain employee.

Despite impressive achievements in generating, extracting, formatting, structuring, and managing the explicit knowledge, the implicit knowledge is becoming the predominant form of the knowledge in the digital economy. In the digital economy, the interaction of specialists will create competencies that take the form of collective ownership and accumulate intellectual capital. All this, with the expected complexity of subject areas, will be accompanied by an increase in the problem of the need to transform the continuously increasing volume of the implicit knowledge into the explicit knowledge. It follows therefrom that it is important for an effective use of the implicit knowledge in the digital economy that we have adequate tools to activate the processes of transformation and digitalization of the implicit knowledge, contributing to the building of core competencies through intellectual activity and targeted interaction between individuals. And here one of the approaches to the activation of the information support of the transformation and digitalization processes of the implicit knowledge is an improvement of the known spiral model made by I. Nonaka and H. Takeuchi.



### **3. RESEARCH OF MODELS AND TOOLS FOR DETECTING THE IMPLICIT KNOWLEDGE**

The implicit knowledge allows each participant in productive activities to solve problems for achieving important practical goals, which, in turn, motivate them to obtain new knowledge that helps them in their professional activities focused on solving scientific or practical problems. According to the spiral model proposed by I. Nonaka and H. Takeuchi which takes into account a number of stages, the organizational knowledge has to be created through a continuous dynamic interaction of non-formalized and formalized knowledge. The first stage is socialization (communitization) is a process by which one participant of the process receives implicit knowledge (abilities, skills, know-how, etc.) from another one through a routine interaction experience. For example, prepared standard scenarios for the initial diagnosis of incidents can help, but it is unlikely to allow you to give employees (participants) all the necessary skills to work out the prepared scenarios. Essentially, at this stage, the implicit knowledge is systematized and artifacts are accumulated for an intermediate organization of the explicit knowledge, i.e. it is possible to provide employees with the demanded implicit knowledge, supplementing the explicit knowledge by eliminating free zones in the system knowledge.

The second stage is externalization (alienation) as a process, the transition from the implicit knowledge to the explicit knowledge is a kind of qualitative leap. From the individual components of the implicit knowledge, a whole system of new explicit knowledge can be created. Therefore, an externalization within the framework of the continuous interaction of the implicit and explicit knowledge is a process of converting quantity (implicit knowledge) into quality (explicit knowledge). If we address the example of typical scenarios for incident diagnostics, then at the externalization stage, it is necessary to record in more detail and clarity the actions of employees to conduct incident diagnostics in the implementation of the scenario, and to strengthen this process, add the development and conduct of training to the regulations. The next stage termed by I. Nonaka and H. Takeuchi as a combination (combining) and meaning a transition from one form of explicit knowledge to another, requires a clarification in terms of terminology and functionality. As a matter of fact, within the framework of this stage there is a development of the explicit knowledge and organization of its new forms with the invariability of its content, i.e. the various forms of knowledge are not combined here, but their increase (diversification) through the reproduction of new forms of knowledge, the basis of which is the initial form of the explicit knowledge. Consequently, this stage in the spiral model is proposed by the authors to be called a “diversification”.

At the stage of internalization (according to I. Nonaka and H. Takeuchi) a consolidation of knowledge occurs through the process of converting the explicit knowledge into the implicit one. Thus, at this stage, the formation of abilities, skills, know-how, etc., i.e. the implicit knowledge based on the explicit knowledge recorded in regulations, instructions, rules, provisions, etc. Functionally, this stage means the process (procedure) of initiating ideas, hypotheses, techniques, approaches provoked by different kinds (types) of the explicit knowledge. Therefore, the explicit knowledge becomes essentially within this stage a source of increasing a new implicit knowledge, i.e. each new process, action, reception is usually carried out sensibly. After making the necessary number of repetitions, a skill, a habit is formed, and this new one is carried out without much effort, unconsciously. It follows therefrom that an acquisition of the implicit knowledge expressed in skills, habits, through regulatory documents (instructions, rules, regulations, standards, etc.), approaches to productive actions (explicit knowledge) is acquired at this stage.

As for the name of this stage, it should be noted its technological orientation, which consists in the transition from the explicit knowledge to the implicit one, as a result of the process of initiation, generation of ideas, hypotheses, know-how due to the variety of explicit knowledge generated at the previous stage. Hence, it is more appropriate to refer to this stage as, for example, "learning" or "activation".

As a result, using the improved model of knowledge conversion as the basis that consists of several modes / stages (updated by the authors): Socialization  $\Rightarrow$  Externalization / Alienation  $\Rightarrow$  Diversification / Combination  $\Rightarrow$  Absorption / Activation / Internalization, one can assume such spiral (cyclic) development contributes to the multiplication of different forms of knowledge as well as specifies its conversion and evolution. Only then we can say that employees and an organization as a whole have acquired new competencies, allowing them to achieve a qualitative change in practice, which is the full, consistent and irreversible transition of such organization to a new competitive state in the digital economy. In various scenarios which describe business processes, intelligent models, know-how, innovative practices and so on are usually the important sources of valuable but often implicit or hidden knowledge. Simulation and digitization of processes, which create the basis of the said stages, along with attributes of knowledge that come with them, are not less relevant for a full-on implementation of the whole explicit and implicit knowledge cycle. And there we need knowledge conversion models with their customary language and structure (for example, the improved spiral model), enabling to share and modify knowledge.

#### **4. ANALYZING THE IMPLICIT KNOWLEDGE TRUST ISSUES AGAINST THE BACKDROP OF ECONOMY DIGITAL TRANSFORMATION**

Transition to the digital economy is grounded on establishing the digital enterprises, which are understood as legally established organizations, which allow to enable, through information technologies, provision of physical or virtual products or services within one or more digital ecosystems [16]. Digital ecosystems are formed by linking disparate networks, devices and sensors based on protocols and digital technology, which leads to the blurring of geographical boundaries and the destruction of traditional industry business models. At the same time, new opportunities are emerging to develop in-house business ecosystems and to create digital business models that allow for greater value generation. According to M. Skilton, the key concept in building a digital enterprise is the idea of digital workspace, which makes it possible to determine how the digital ecosystems can be used to create value in the network. A digital workspace is to be defined by physical and virtual data and objects that are associated with specific areas and can work together within a digital enterprise. In essence, digital workspaces are digital platforms that support a multi-layered set of capabilities unique for each enterprise [16]. Transition to the form of a network organization is dictated not so much by digital opportunities as by a change in fundamental understanding of the economy and a transition to a new knowledge-based competition. The point of all of these has been significantly highlighted by P. Adler in his article [1], which provoked a heated discussion at the time. Knowledge-based enterprises, in his view, were characterized by the transition to a third form of organization, based on the community / trust mechanism. The established forms of organization driven by the hierarchy / authority and market / price mechanisms do not provide incentives for innovation and make it hard to generate and share knowledge [7]. The main features of network organizations functioning are the ability to learn and to be flexible. An aptitude to learning is to be determined by a need to swiftly bring an innovative product to the market. Network organizations are therefore presented in the form of a learning network, whose key objective is to ensure rapid access to knowledge sources and convert knowledge, often implicit, into a material innovative product.

Flexibility is also a priority in creating a network organization, as far as the training of a wide range of employees and network participants facilitates the experimentation with new methods and technology. In the meantime, organizations start to resemble a network of contracts, while innovation reduces the volume of contractual obligations [8]. Due to the fact that the knowledge in modern economy is a competitive advantage, and that the networks are a source of strategic knowledge, of digital enterprises, who keep their economic relations in the form of a network of value, enjoy a higher innovation potential. However, to implement this potential, digital enterprises need to develop a collaborative community, because when digital spaces get complicated, a collaborative network rather than a separate company becomes the center of innovation [20].

Personal knowledge gained through codification may be transferred into organizational knowledge or, collectively, the intellectual capital of an enterprise, and after careful consideration they can be made available to the general public [6]. First of all, this goes to the discovery of implicit knowledge, which is purely personal but also plays a significant role in the organizational culture and has a significant impact on the adoption of management decisions and business processes. Table 1 shows some examples of implicit knowledge in the context of components and aspects of a digital business model. The table is based on the VISOR framework [5].

<b>DBM component</b>	<b>DBM aspect</b>	<b>Example of implicit knowledge</b>
Value proposition	Customers	culture, customs, habits, beliefs
	Consumer value	quality, competitive advantage, fashion, values
	Customer understanding	perception, need, hidden demand, expectations, behaviour
	Customer relations	experience, scenarios, observation, negotiation
Interface	Customer interface	convenience, comfort, customization, aesthetics, privacy
	Value interfaces	business knowledge, mediation, prospects, values
	Services and contacts	capabilities, availability, coordination, scenarios
Service platform	Key resources	experience, competencies, know-how, tasks, talents, practices
	IT infrastructure	performance, reliability, safety
	Technology	requirements, interoperability, development, adaptability
	Logistics flow	availability, technological environment, opportunities of partners
	Key technology investments	IT opportunities, limitations, financial gain
Operating model	Organizational characteristics	business opportunities, availability of resources, exclusivity, legal protection
	Key partners	synergy, complementarity, values, reliability
	Channels	availability, throughput, reliability
	Value network	values, motives, sustainability
	Related activities	focus of activities, awareness, task management, probability of success
	Stakeholder network	competitiveness, customer relationships, relationship management, compliance
Revenue model	Financial model	possibility of diversification, conjuncture, price competition, risks
	Financial aspects	key trends, market dynamics, industry prospects, financial environment
	Income flow	expected demand, tendency in taxation, solvency, legal guarantees

*Table 1: Examples of implicit knowledge in the context of a digital business model (DBM)*

If the implicit knowledge has not been studied and expressed, significant problems may occur in the course of a digital enterprise functioning. Therefore, approaches to the implicit knowledge management in a collaborative network are critical in building and developing digital businesses. Trust is the key coordination mechanism for building a knowledge-based network organization. According to Botsman [4], trust can be understood as “a strong connection with the unknown”. At the same time, trust involves a risk analysis and is based on an assessment of the likelihood of a favourable outcome.

The role of trust in knowledge management is widely publicized in scientific literature [3, 6, 7, 11]. One of the most discussed issues is the impact of trust on the identification of the implicit knowledge. As trust has an effect on cooperation and increases the intensity of interaction between members of an organization or a network, it is considered to be crucial for transforming personal knowledge into organizational one [6].

Despite the fact that the notion of trust is multifaceted, most often two types of trust are analyzed in research of trust in relation to network organizations: affective and cognitive. Affective (personal) trust, based on interaction between people and organizations, is emotive and addresses such issues as mutual respect, care and kindness. Cognitive trust (trust on knowledge) is based on the reliability, competence and responsibility of an employee. Works of a number of authors contain approaches to the development of both affective and cognitive forms of trust [6, 7, 8].

In the development process of the digital economy, another form of trust has emerged, that associates with digital technologies, such as cloud computing, mobile computers, Big Data, social networks and IoT, which process, store and disseminate information, which also contains corporate knowledge. Such a form of trust is to be called the digital trust. It includes such aspects as confidentiality and transparency of data, validity and controllability of the algorithms used, that were based on artificial intelligence technologies, the impact of robotization on employment of the local population [10].

A feature of digital trust is its distributed nature in accordance with the concept drawn up by Rachel Botsman, who has highlighted the following three stages in the development of the approach to the trust:

- *the local trust* that is prevailing at small communities and based on personal connections;
- *the institutional trust*, prevailing at the industrial age and based on the activities of intermediaries and regulation authorities;
- *the distributed trust* based on connections among people supported by networks, systems, and platforms [4].

Distributed trust, which is characteristic of digital enterprises, complies with a trend of people starting to trust people more than institutions and businesses [10]. In case of digital enterprises operating on the basis of collaboration in the digital ecosystem, Botsman formulated a trust stack model that is based on three levels of trust formation: 1) a trust in an idea, 2) a trust in a platform, 3) a trust another person (or sometimes a computer or robot) [4]. In fact, these levels reflect three forms of trust: cognitive, digital and affective. The development of digital trust is to be carried out by building an ecosystem of trust in the digital environment that ensures, at technological level, harmonization of interests of the participants in digital interactions, support for life cycle of contracts, social and economic justice, and transparency of expectations [10]. For this purpose, technologies such as blockchain and smart contracts are increasingly used.

The considered forms of confidence building can be used in digital enterprises to identify and use of the implicit knowledge. For this purpose it is necessary to form an approach to transformation of implicit knowledge into explicit in the process of functioning of digital enterprises on the basis of trust, which links three scientific concepts: revealing implicit knowledge, building digital enterprises and trust management.

## **5. A CONCEPTUAL FRAMEWORK TO ENSURE TRUST IN IMPLICIT KNOWLEDGE FOR DIGITAL ENTERPRISES**

Identification and share of implicit knowledge among digital enterprises requires achieving and maintaining of a certain level of trust. Therefore, ensuring trust must be part of management practice. For this purpose, it is necessary to build up a model of trust, to define methods of its maintenance in order to maintain the target level, to organize the process of trust maintenance, and to define mechanisms of trust management. The model of trust is a framework that determines what forms of trust should be developed at digital enterprises. Considering the model of the trust stack described above, these forms should include cognitive, digital and affective trust, which together shall form trust-based relationships in digital enterprises and contribute to a better dissemination of knowledge in the values network. The main advantage of this model is that for each of these forms of trust a wide arsenal of trust-building methods has been described and tested in the scientific literature.

Methods of ensuring digital trust have being discussed in the scientific literature on the digital economy. The main methods of ensuring trust are technologies for managing risks of information security, maintaining the required level of confidentiality and availability, as well as managing the life cycle of contracts in the digital environment. The affective trust is a trust based not on calculations, but on shared values and reciprocal understanding. Therefore, it can be called an unconditional trust. It is this form of trust that is best suited for detecting the implicit knowledge. The main strategies for building an affective trust are interpersonal communication and synergetic teamwork [7]. One of the peculiarities of increasing the affective trust for digital enterprises is that individuals interact, usually in a virtual environment, which significantly limits the possibilities of communication due to the lack of non-verbal means of information transfer. This is to be compensated by the possibilities of digital technologies, as well as by a clearer goal setting, role assignment and responsibilities for task solutions in a team.

Trust process is based on analysis and assessment of possible risks and propensity to trust. The risk assessment is based on information concerning the situation, meanwhile the decision-making can be influenced by such factors as personal characteristics and communicative attitudes of a trustor. The propensity to trust is to be determined by the perception of reliability of the trusted party, experience and knowledge. Decision making in accordance with the factors listed above allows to determine the degree of trust [3]. Confidence or mistrust can affect the process of identifying the implicit knowledge significantly. The digital aspect of trust management involves the development of digital technologies to maintain the digital trust. For digital enterprises, the basic direction for maintaining the digital trust is to develop an ecosystem of trust [18], aimed at managing information security, confidentiality and contract lifecycle support. To increase trust, it is reasonable to develop smart contract practices, risk management automation, digital reputation and data privacy management [13]. A digital enterprise can be considered as a social network containing social assets that are distributed and are necessary to be coordinated, that is, to do an orchestration. For the development of communication interaction, it is also reasonable to apply the framing [7]. A conceptual framework for ensuring confidence in implicit knowledge for digital enterprises is shown in figure 1.

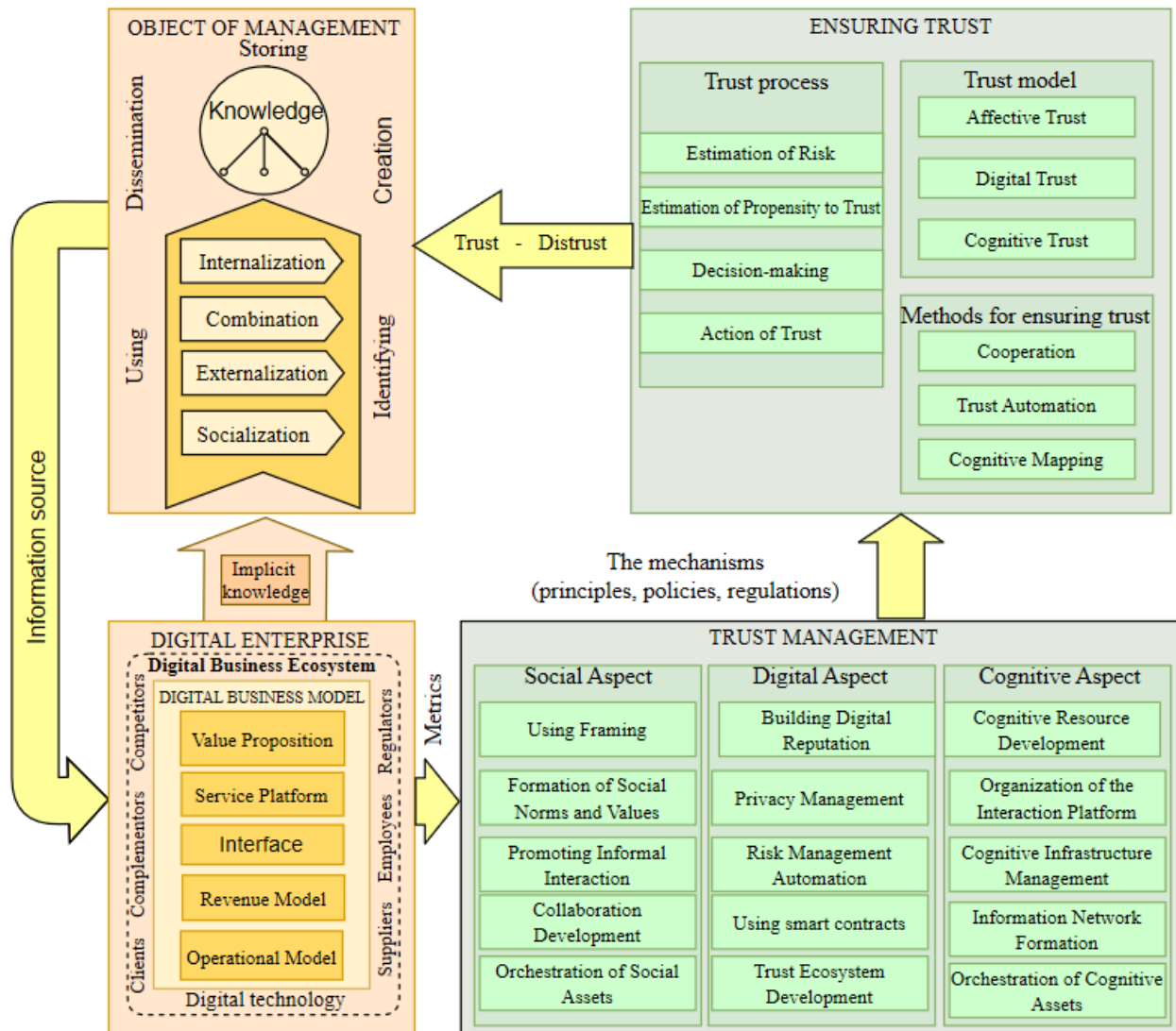

Figure 1: Conceptual basis for revealing implicit knowledge in the process of functioning of digital enterprises based on trust

In the displayed model, 4 interrelated domains can be distinguished as follows: digital enterprise, knowledge management process, trust assurance and trust management. The model of a digital enterprise reflects the digital business model based on the VISOR framework [5], as well as a digital business ecosystem model. The domain of the implicit knowledge is based on an improved knowledge spiral (Nonaka and Takeuchi) and on the model of knowledge management life cycle. The trust domain includes a trust model, methods of trust management and a trust process. The domain of trust management reflects social, digital and cognitive practices aimed at trust development. The trust building process is depicted by means of arrows. The starting point is the arrow containing metrics that reflect an organizational learning process, a need to identify the implicit knowledge, and an established level of trust. The arrow “The mechanisms” between the domain of trust management and the domain of trust-building measures reflect management mechanisms aimed at trust building. The arrow between the domain of trust management and the process of implicit knowledge revealing shows an established level of trust, which predetermines the level of revealing and spreading for the implicit knowledge.

The arrow “Information Source” shows the artefacts of knowledge obtained as a result of implicit knowledge revealing, which have been transferred for application at a digital enterprise. This conceptual framework can be used to improve the identification and dissemination of the implicit knowledge among digital enterprises, which will significantly increase their sustainability in a rapidly changing world.

## 6. CONCLUSION

In the course of the study, the authors have found: 1) a key problem of knowledge management during the digital economy transformation is a detection and use of implicit knowledge; 2) identification and share of implicit knowledge among digital enterprises requires achieving and maintaining of a certain level of trust; 3) the existing approaches to ensure trust among digital enterprises have been studied in the context of various scientific fields and are fragmentary. Based on the above, the authors have developed a scheme with examples of the implicit knowledge for all the aspects of the digital business model, which demonstrates an importance of the issue of revealing the implicit knowledge in the digital enterprises' establishing; they have proposed a conceptual basis that reveals the implicit knowledge in the process of functioning of digital enterprises on the basis of trust, and which consolidates the basic approaches of three scientific areas: knowledge management, trust building and digital transformation of enterprises. This conceptual basis can be used for development of practical approaches to reveal and distribute the implicit knowledge among digital enterprises.

## LITERATURE:

1. Adler P. (2001). Market, Hierarchy, and Trust: The Knowledge Economy and the Future of Capitalism. *Organization Science*, 2001 (Vol. 12, No. 2), pp. 215-234.
2. Bateson G. (1979). *Mind and Nature: A Necessary Unity (Advances in Systems Theory, Complexity, and the Human Sciences)*. New York: Hampton Press.
3. Blöbaum B. (2016). Key Factors in the Process of Trust. On the Analysis of Trust under Digital Conditions. In Blobaum B. *Trust and Communication in a Digitized World: Models and Concepts of Trust Research* (251 p.). Cham, Switzerland: Springer International Publishing AG.
4. Botsman R. (2017). *Who can you trust?* New York: Hachette Book Group.
5. El Sawy, O., Pereira, F. (2013). *Business modelling in the dynamic digital space. An ecosystem Approach*. New York: Springer Heidelberg.
6. Huotari M., Iivonen M. (2004). Managing Knowledge-Based Organizations Through Trust. In Huotari M., Iivonen M. *Trust in Knowledge Management Systems in Organizations* (296 p.). Oakland, USA: Idea Group Publishing.
7. Leung L., Lau K. (2007). The role of trust in knowledge management. In Yau O., Chow R. *The harmony versus conflict in Asian business managing in a turbulent era* (238 p.). New York: Palgrave Macmillan.
8. Mandelli A. (2004). Self-Organization and New Hierarchies in Complex Evolutionary Value Networks. In Huotari M., Iivonen M. *Trust in Knowledge Management Systems in Organizations* (296 p.). Oakland, USA: Idea Group Publishing.
9. Nonaka, I., Takeuchi H. (1995), *The knowledge creating company: how Japanese companies create the dynamics of innovation*. New York: Oxford University Press.
10. Osburg T. (2017). Sustainability in a digital world needs trust. In T. Osburg, C. Lohrmann, *Sustainability in a digital world: new opportunities through new technologies* (268 p.). Cham, Switzerland: Springer International Publishing AG.

11. Pashkov P., Pelykh V. (2020). *Digital transformation of financial services on the basis of trust*. Book of proc. of the 50th International Scientific Conference on Economic and Social Development, “Economic and Social Development“, Chelyabinsk, 13-14 February 2020, pp. 375-383, available at: <http://www.esd-conference.com/>.
12. Polany M. (1966). *The Tacit Dimension*. London: Routledge & Kegan Paul.
13. Ryan P. (2019). *Trust and Distrust in Digital Economies*. New York: Routledge.
14. Schoorman D., Mayer R., Davis J. (2007). An Integrative Model of Organizational Trust: Past, Present, and Future. *The Academy of Management Review*, 2007 (Vol. 32, No. 2), pp. 344-354
15. Simon H. (1973). Applying Information Technology to Organization Design. *Public Administration Review*, 1973 (No. 33), pp. 268-278.
16. Skilton M. (2016). *Building digital ecosystem architectures. A guide to enterprise architecting digital technologies in the digital enterprise*. Hampshire, United Kingdom: Palgrave Macmillan.
17. Taylor F. (1911). *The Principles of Scientific Management*. New York and London: Harper & brothers.
18. *The Open Group guide: Guide trust ecosystem*. (2014). Reading, United Kingdom: The Open Group.
19. Usoro A., Sharratt M., Tsui E., Shekhar S. (2007). Trust as an antecedent to knowledge sharing in virtual communities of practice. *Knowledge Management Research & Practice*, 2007 (No. 5), pp. 199–212.
20. Whittington K., Owen-Smith J., Powell W. (2009). Networks, Propinquity, and Innovation in Knowledge-Intensive Industries. *Administrative Science Quarterly*, 2009, (Vol. 54, No.1), pp. 90-122.



# INTELLECTUAL CAPITAL AND ITS COMPONENTS AS AN OBJECT OF ACCOUNTING

**Yana Ustinova**

*Novosibirsk State University of Economics and Management, Russia  
ustinova\_pr@mail.ru*

## **ABSTRACT**

*The concepts of “intellectual capital”, “intellectual assets”, “human, structural, client capital”, “intellectual property”, “intangible assets” are revealed. At the same time, specific features of the elements of intellectual capital as objects of accounting and the associated difficulties in their accounting are investigated. The author analyzes the limitations of the current concept of accounting for intangible assets, the factors that determined them, the methods used to overcome them, and the reasons for their insufficient effectiveness. The study shows the need to develop the theory and methodology of accounting in order to expand the informational restrictions on the reflection of intellectual capital in financial statements (including through the management report recommended by the IASB).*

**Keywords:** *Information restrictions, Intangible assets, Intellectual assets, Intellectual capital, Intellectual property, The concept of accounting for intangible assets*

## **1. INTRODUCTION**

In the modern economy, there is a noticeable shift in emphasis in terms of economic importance from physical and financial capital to intellectual capital. A few decades ago, the economic potential of companies was determined by the valuation of their fixed assets, production and inventory, the availability of cash, debts. At present, the assessment of the economic potential for the availability of intellectual capital is slowly but surely coming to the fore, since it is it that directly affects the efficiency of use of all other types of capital of companies. The globalization of the economy, the intensification of competition, the development of engineering and technology, the widespread use of intellectual resources stimulate the interest of stakeholders in information about its intellectual capital. Moreover, the structure of intellectual capital is not homogeneous. Its constituent elements have a different effect on the economic potential of the company and the formation of its value. In addition, intellectual capital is a unique accounting object, the specific features of which are due to the lack of physical form and a high degree of uncertainty regarding the economic benefits of its use. The aim of the article is to study the features of intellectual capital and its elements as an object of accounting.

## **2. RESULTS AND DISCUSSION**

### **2.1. Intellectual capital and its elements**

So, the concept of intellectual capital and its structure are the subject of scientific discussions. There is a need to specify them for research purposes. Intellectual capital is the totality of all the company's intellectual resources (associated with the corresponding assets and liabilities), as well as a system of economic relations for the use of these resources in order to create business value. The components of intellectual capital are considered: 1) human capital (total labor force, special knowledge, skills of employees), 2) structural (organizational) capital (intellectual property, information resources and technologies, electronic networks, organizational structure and business management system) and 3) relational (client) capital (relations with clients and business partners regarding customer service, commercial ideas and distribution network of products (services), brand and business reputation).

By “intellectual resources” of a company are understood the results of intellectual activity and other intangible resources that ensure the individualization of the product, organization and conduct of the business and the company itself in relations with the external environment. Part of the intellectual resources is “human resources”, due to the labor contribution of workers. Intellectual assets are part of intellectual capital, net of resources such as business organization and stable loyal clientele, for which the company does not have a sufficient degree of control. “Intellectual property” is a part of intellectual resources protected by law (results of intellectual activity and equivalent means of individualization). Thus, intellectual capital, along with physical and financial capital, determines the financial and economic situation of the company, its investment attractiveness and competitiveness. Moreover, it is intellectual capital that acts as a driver for the efficient use of physical and financial capital. This explains the interest of the company's stakeholders in the disclosure of information about its intellectual capital. However, in financial statements, intellectual capital is disclosed through the category of intangible assets. Moreover, in the broad sense, intangible assets and intellectual capital are considered as synonyms. In a narrow sense, intangible assets include a part of intellectual capital that meets the recognition criteria provided for by the accounting standard. The first approach, with the separation of information on the elements of intellectual capital, meets the interests of the stakeholders of the company to the maximum extent, who need data on intellectual capital to build their own economic models for making managerial decisions, regardless of whether they meet the criteria for recognition of accounting standards. At the same time, the formation of financial statements in accordance with accounting standards restrains intangible assets within a narrow framework, extremely impoverishing information content and reducing the usefulness of financial statements for users. Thus, increasing the usefulness of financial statements for users necessarily requires enriching its information content in terms of disclosing information about the intellectual capital of an organization. For this, it is necessary to take into account the specific features of intellectual capital as an object of accounting.

## **2.2. Specific features of intellectual capital as an object of accounting**

The specific features of intellectual capital as an object of accounting and part of intangible assets can be explained by a combination of three factors:

- 1) Intangibility. Intellectual capital does not have a hard limit in space; the fact of its presence and condition is not subject to physical control. The criterion of control over an object seems ambiguous, because, unlike the objects of the material world, an intangible object can belong to several persons at the same time. The interpretation in practice of the principle of priority of economic content over the legal form as oblivion of the legal nature of the object only strengthens multiple accounting problems, since the use of economic and accounting potential is possible only in conjunction with the legal one. This argument is shared by both Russian scientists (E.A. Yershova [29], S.A. Kuzubov [14, p. 94]) and their foreign colleagues (L.S. Moerman and S. van der Laan [20, p. 243-248], R. Petrova [23, p. 63], L. Hunter, E. Webster and A. Wyatt [10, p. 7]). The intangibility of intangible assets is closely associated with a higher degree of uncertainty associated with them and a lower degree of predictability, for example, regarding the ability of objects to generate income in the future, the period of time during which it is expected to receive this income, the life cycle of the object, factors affecting the possibility of extraction income or their exhaustion, etc. This conclusion is confirmed by the results of empirical studies by E. Oliveras and O. Amat [21, p. 5], R. Petrova [23, p. 65], M. Brassell and J. Maguire [3, p. 15], T. Karius [13, p. 1], D. Starovic and B. Marr [25, p. 7], B. Lev [16, p. 131], A. Wyatt [27, p. 218]. The high degree of uncertainty associated with intellectual property is also predetermined by the weakness of property rights to its objects, the lack of full control over the economic benefits of

their use (B. Lev [16, p. 7]), which in practice is significantly reduced by the actions of competitors, and the variability of external environment (including tastes of consumers). The intangibility of intangible assets also implies a close relationship with tangible assets in the process of use for the purpose of generating income, which, in turn, complicates the assessment of the potential for their future profitability and increases the degree of uncertainty associated with them, as confirmed by empirical research by T. Karius [13, p. 8-9], B. Lev [16, p. 7], B. Lev and J. Daum [17, p. 6, 12].

2) Dualism. Duality manifests itself, first of all, in the very nature of intellectual capital. From an economic point of view, intellectual capital is an organization's assets and liabilities that ensure, along with physical and financial capital, its activity and form its value. However, part of the intellectual capital does not fall under the scope of legal protection instruments and guarantees, and part, primarily intellectual property, is an object of civil legal relations in respect of which a company may own a different scope of rights, for various reasons, having different durations and different the degree of completeness of control over the extraction of income from the use of the object, and therefore their analysis can be very informative for the company's stakeholders. In addition, dualism also reflects an internal contradiction in the valuation of intangible assets. On the one hand, there are no restrictions on the extent of use with respect to intangible assets, which is associated with the weakness of property rights and network effects (increase in value with an increase in the number of users). Moreover, intangible assets, in fact, are goods (through the assignment of patents, trade in licenses and the results of research and development, etc.). But, on the other hand, most intangible assets are specific to their company, which is closely related to the fairness of the principle of business continuity, the absence of an active market for these assets (their low liquidity), and in some cases, the irreversibility of investments in these assets. In addition, they may not cost anything on their own, but they work in the system and acquire value due to the synergistic effect. We should not forget about the inherent high level of initial investments along with a low level of marginal costs, which leads to economies of scale and the specifics of profitability. Finally, even single transactions with intangible assets that are carried out are not transparent (their details are not disclosed to the public, their uniqueness prevents the use of analogy, etc.), which maintains a high level of information asymmetry between the buyer and the seller. As a result, this dualism, taking into account the sequence of elements of the accounting procedure, entails the multidimensionality, multifactorial nature of the problem of accounting disclosure of information on intellectual capital. Moreover, each of its aspects, each factor is of interest to a specific group of users, with certain information needs. In this regard, the disclosure of information exclusively in any one aspect directly affects the interests of all other groups of users of financial statements (K. Artsberg, N. Mehtiyeva [2, p. 12], M. Greenwelle and G. Tibbits [8, p. 3]).

3) Focus on the future. If traditional accounting is focused on facts that have happened in the past, then with regard to accounting for intellectual capital for users of financial statements, of interest are, first of all, those facts that are directly related to the future. In particular, J. Jarrett [11, p. 1] notes that the rules of financial accounting should not ignore the principle of conservatism, but should include methods for the economic evaluation of future income from intellectual capital, reflecting the rate of return created by the organization, which, in turn, depends on the availability and efficient use of intellectual capital. B. Lev directly points out that the modern stakeholder is less and less interested in the traditional contents of the balance sheet and income statement. He

needs information about the future of the company, the possibilities of its development, the creation of future value, the preservation and development of competitive advantages, which requires the provision of detailed information about the intangible assets of the company [16, p. 105-127].

These features of intellectual capital as an accounting object greatly complicate the methodology for preparing and disclosing accounting information and at the same time minimize the possibility of using traditional accounting tools that have become generally accepted within the framework of the industrial accounting paradigm. All this determines the informational limitations of the modern concept of accounting for intellectual capital.

### **2.3. Limitations of the modern concept of accounting for intangible assets**

The current concept of accounting for intellectual capital, both Russian and international, considers it exclusively through the prism of the category of intangible asset. Theoretically, this allows you to reflect in the financial statements only that part of intellectual capital that fits into the scope of the concept of intangible assets (and only in the ways provided for by the standards), while no accounting tools are provided for the other part by the standards. In practice, the majority of intangible assets are not reflected in accounting at all or are reflected at a cost significantly different from the market assessment. In other words, the result of the formation in the financial statements of data on intangible assets in accordance with the requirements of accounting standards are multiple informational restrictions. Information restrictions are comprehensive, ranging from the spectrum of facts of economic life in relation to intellectual resources reflected in accounting and reporting, and ending with cost estimates of these facts.

As examples of the described limitations, mention may be made of:

- refusal to include an object into the composition of intangible assets, the possibility of deriving future economic benefits from the use of which is not obvious at the time of recognition;
- reflection in the structure of intangible assets of an object at actual costs from the moment the development stage is recognized (in fact, only the costs of patenting);
- lack of reflection of the burdens accepted by the copyright holder when issuing a certain number of licenses to use the facility.

Thus, we can state the "information deficit" in the financial statements in relation to intellectual capital. The consequence of this deficit is the lack of reporting ability for the user to obtain reliable and faithfully prepared information about the intangible resources of the company, generating additional income from the legal monopoly on the intellectual property, due to the synergistic effect of interaction with other assets, competent management, a good location and other similar reasons. Given the steadily increasing importance of intellectual capital in the global economy, this problem requires its immediate and effective solution. Key requirements for this decision: adaptability to the growing synergistic effect of intellectual capital in the company's business, the ability to take into account the individual characteristics of the company and focus on the numerous, diverse and dynamically changing information needs of its stakeholders.

Today, researchers are discussing two main ways to overcome the information deficit regarding intangible assets in financial statements:

- 1) Supplementing traditional financial statements (while maintaining the accepted concept of its preparation) with a report on intangible assets (a report on intellectual capital) (R. Kaplan and D. Norton [12, p. 57], L. Edvinsson and M. Malone [7, p. 32-39], B. Lev [15, p. 125-130],

A. Wyatt and M. Abernethy [28, p. 15-16, 22-25], E. Oliveras, Yu. Kasperskaya [22, p. 4, 12], L. Hunter, E. Webster, A. Wyatt [10, p. 11-12], I. Abeysekera [1, p. 3-4], D. Cormier, M.J. Ledoux [6, pp. 3-6, 18]). The obvious advantage of this solution is the stability of accounting regulation, which is not subject to revision. However, additional disclosure does not compensate for gaps in traditional financial statements, reduce its value for decision-making and trust in it, and does not guarantee the satisfaction of the information needs of users of statements.

2) Modification (expansion, revision of the concept of preparation) of traditional financial statements (B. Lev and J. Daum [17, p. 8-12], I. Lopes [19, p. 103-104], R. Heinrich [9, p. 35], S. Chander and V. Mehra [5, p. 2-5, 24], N. Rea and A. Davis [24], J.-Ch. Wu and C. Lin [26, p. 346], B. Lev and S. Raigopal [18]). This option is aimed at a long-term perspective, which involves the development of the theory and methodology of accounting and reporting, the result of which should be the expansion of the information boundaries of traditional reporting in general and intangible assets in particular, including and through the revision of accounting regulation concepts and the development of accounting standards, the development of the concept of professional judgment of an accountant. But at the same time, this decision involves a deviation from accounting standards, an increase in the cost of developing accounting regulation and control over its compliance, the need to review established methods for preparing financial statements, which serves as a powerful deterrent.

It is not surprising that in practice the first option (R.P. Bulyga [4, p. 173]), which is focused on the short term, preserving the prevailing accounting practices and accounting standards through the introduction of an additional information block, gained the most recognition. However, the generation of these reports is voluntary in nature, their structure and content are not regulated and in practice may vary significantly depending on the size of the business, industry and the characteristics of the company. Intellectual capital reporting data may not include elements of alignment with financial reporting data. The main drawback of the report on intellectual capital is the averaging of user needs, the desire for a compromise that suits everyone, but is not able to satisfy anyone. All this determines the growing interest in the circle of researchers to the question of the need to revise the methods and methods of preparation and disclosure of accounting information, primarily in relation to intangible assets. To date, the IASB has decided to conduct a series of studies, followed by a discussion of the option of providing investors with information about intangible assets through a management report. However, based on the tasks set for the researchers by the IASB, there is reason to believe that the new management report will most likely not overcome the problematic situation that is taking place. First of all, regarding the interconnection of information on intangible assets, which is disclosed in the financial statements, with the data of the projected management report.

### **3. CONCLUSION**

So, in the traditional financial statements there is a deficit of information regarding intangible assets both in terms of the range of recorded transactions and in terms of their valuation. At the same time, the preparation of additional reports on intangible assets, in addition to traditional financial statements, does not solve the problem of disclosing information that users need, does not ensure its comparability and completeness of coverage. Financial statements that do not reflect reliable and faithfully prepared information about intangible assets lose their status as the most important source of information when making management decisions. At the same time, additional disclosures in special reports in some cases are used as tools for manipulating the opinion of stakeholders in the context of competition for access to economic resources.

The considered specific features of intellectual property as an object of accounting not only determine the informational limitations of the modern concept of its accounting, but also require the development of accounting theory and methodology in order to expand these restrictions. At the same time, it is necessary to analyze the information needs of stakeholders, factors explaining the boundaries of informational content of reporting, the possibilities of expanding these boundaries by presenting and disclosing relevant data, as well as a methodological approach that ensures that reporting data is oriented towards providing a communicative function with reporting users. The unique nature of intangible assets as an accounting item implies a certain degree of freedom in making accounting decisions in preparing financial statements, with the mandatory disclosure of the approaches used, the circumstances taken into account and the associated uncertainties in the explanations. Thus, a revision of the concept of preparing reporting information is required, the development of new theoretical and methodological provisions that would provide the opportunity to go beyond the informativeness of the industrial accounting paradigm and users to build reports based on it based on their own models of economic decision-making.

#### LITERATURE:

1. Abeysekera, I. (2007). *Intellectual Capital Accounting: Practices in a Developing Country*. Routledge. 2007. 224 p.
2. Artsberg, K., Mehtiyeva, N. (2010). *A literature review on Intangible assets. Critical questions for Standard setters*. Working Paper. School of Economics and Management. June 2010. 34 p.
3. Brassell, M., Maguire, J. (2017). *Hidden Value: A Study of the UK IP Valuation Market*. August 2017. UK. Intellectual Property Office. 148 p.
4. Bulyga, R.P (2012). Kontsepsiya intellektual'nogo kapitala kak osnova povysheniya informatsionnoy prozrachnosti i dostovernosti vneshney otchetnosti organizatsii [The concept of intellectual capital as the basis for increasing information transparency and reliability of the organization's external reporting] // *Innovatsionnoye razvitiye ekonomiki = Innovative economic development*. 2012. № 2 (8). p. 170-176. (In Russ.)
5. Chander, S., Mehra, V. (2011). A study on Intangible Assets Disclosure: An Evidence from Indian Companies // *Intangible Capital*. 2011. Vol. 7(1). P. 1-30.
6. Cormier, D., Ledoux, M.-J. (2010). *The Influence of Voluntary Disclosure about Intangible Assets Reported in French Financial Statement: The Role Played by IFRS*. Corporate Reporting Chair. October 2010. 36 p.
7. Edvinsson, L., Malone, M.S. (1997). *Intellectual Capital: The proven way to establish your company's real value by measuring its hidden brainpower*. London: Platkus, 1997. 430 p.
8. Greenwell, M.M., Tibbits, G.E. (1992). *Accounting for Identifiable Intangible Assets: No One Right Way*. Accounting and Finance Working Paper 92/37, School of Accounting & Finance, University of Wollongong. June 1992. 20 p.
9. Heinrich, R. (2011). *Valuation in Intellectual Property Accounting*. UNECE Team of Specialists on Intellectual Property. Bishkek. 11 October 2011. 43 p.
10. Hunter, L.C., Webster, E., Wyatt, A. (2009). *Identifying Corporate Expenditures on Intangibles Using GAAP*. Melbourne Institute Working Paper Series, Working Paper No. 12/09. 2009. 15 p.
11. Jarrett, J.E. (2017). Intellectual Property Valuation and Accounting // *Intellectual Property Rights*. 2017. Vol. 5(1). p. 181-182.
12. Kaplan, R.S., Norton, D.P. (1992). The Balanced Scorecard: Measures that Drive Performance // *Harvard Business Review*. January-February 1992. Vol. 70. № 1. P. 71-79.

13. Karius, T. (2016). *Intellectual Property and Intangible Assets: Alternative Valuation and Financing Approaches for the Knowledge Economy in Luxemburg*. Research Report. EIKV-Schriftenreihe Zum Wissens und Wertemanagement. 2016. № 3. 92 p.
14. Kuzubov, S.A. (2009). Innovatsionnaya ekonomika i intellektual'nyye aktivy [Innovative economy and intellectual assets] // *Vestnik UGTU-UPI = Bulletin of Ural State Technical University-UPI*. 2009. № 2. p. 89-99. (In Russ.)
15. Lev, B. (1969). *Accounting and Information Theory* (Studies in Accounting Research № 2; Sarasota, Florida: The American Accounting Association). 1969. Chapter 2. P. 130-147.
16. Lev, B. (2009). Nematerial'nyye aktivy: upravleniye, izmereniye, otchetnost' [*Intangible assets: management, measurement, reporting*]. M.: Quinto Consulting, 2009. 240 p. (In Russ.)
17. Lev, B., Daum, J.H. (2004). The dominance of Intangible Assets: consequences for enterprise management and corporate reporting // *Measuring Business Excellence*. 2004. Vol. 8(1). P. 6-17.
18. Lev, B., Raygopal, SH. (2016). FASB prizval pereyti na printsipy [*FASB called for the transition to principles*]. March 3, 2016. Retrieved 20.05.2018 from URL: <https://gaap.ru/news/149381>.
19. Lopes, I.T. (2011). The Boundaries of Intellectual Property Valuation: Cost, Market, Income Based Approaches and Innovation Turnover // *Intellectual Economics*. 2011. Vol. 1(9). P. 99-116.
20. Moerman, L.C. and Van der Laan, S. (2006). Accounting for Intellectual Property: inconsistencies and challenges // *Journal of Intellectual Property*. 2006. Vol. 11(4). P. 243-248.
21. Oliveras, E., Amat, O. (2003). *Ethics and Creative Accounting: Some Empirical Evidence on Accounting for Intangibles in Spain*. Economics Working Paper. № 732. Department of Economics and Business. Universitat Pompeu Fabra. 2003. 21 p.
22. Oliveras, E., Kasperskaya, Y. (2003). *Reporting Intellectual Capital in Spain*. Working Paper. Univeritat Pompeu Fabra. 2003. 21 p.
23. Petrova, R. (2011). Accounting treatment of Intellectual Property in the pharmaceutical industry // *Trakia Journal of Sciences*. 2011. Vol. 9(4). P. 63-68.
24. Rea, N., Davis, A. (2012). *Intangible assets: what are they worth and how should that value be communicated*. 2012. Retrieved 21.05.2017 from URL: [www.buildingipvalue.com](http://www.buildingipvalue.com).
25. Starovic, D., Marr, B. (2005). *Understanding Corporate Value: Managing and Reporting Intellectual Capital*. Chartered Institute of Management Accountants. Cranfield University. School of Management. 2005. 28 p.
26. Wu, J.-Ch., Lin, Ch. (2013). A Balance Sheet for Knowledge Evaluation and Reporting // *Management, Knowledge and Learning*. International Conference June 2013. Zadar, Croatia. P. 341-348.
27. Wyatt, A. (2008). What financial and non-financial information on intangibles is value relevant? A review of the evidence // *Accounting and Business Research*. 2008. Vol. 38(3). P. 217-256.
28. Wyatt, A., Abernethy, M.A. (2003). *Framework for Measurement and Reporting on Intangible Assets*. Working Paper № 12/03. Intellectual Property Research Institute of Australia. Melbourne. 2003. 36 p.
29. Yershova, Ye.A. (2011). Gudvill: osnovnyye problemy i protivorechiya [Goodwill: main problems and contradictions] // *Problemy razvitiya chastnogo prava: sbornik statey k yubileyu Vladimira Saurseyevicha Yema = Problems of the development of private law / S.S. Alekseyev, A.V. Asoskov, V.YU. Buzanov i dr.; otv. red. Ye.A. Sukhanov, N.V. Kozlova*. M.: Statut, 2011. p. 240–252. (In Russ.)

# INTEGRAL ASSESSMENT OF RETAIL DIGITALIZATION

**Zhanna Shnorr**

*Novosibirsk State University Of Economics And Management,  
Novosibirsk, Russia  
Shnorr75@mail.ru*

## **ABSTRACT**

*The purpose of the article is to develop a methodology for the integral assessment of the deployment of digital technologies in the industry aspect from the case study of retail. The article describes the relevance of the integral assessment of the retail digitalization. The existing analytical methodologies studying the level of economy and business digitalization are reviewed and systematized. The article specifies that each of the existing methodologies is an analytical way of a comparative study and rating of the level of digitalization, mainly in the spatial and temporal aspects. It is emphasized that the scope of the methods is determined by the objectives and the taxonomy of the study. The necessity to improve and supplement the methodological tools of the quantitative study of the level of business digitalization in retail from the standpoint of temporary, spatial and industry components is justified. The methodology of the integral assessment of retail digitalization is based on the conceptual principles of potential theory, uses analytical methods of system analysis, an algorithm for structuring problems of industry development in the transition to a digital economy, and the corresponding mathematical tools, and contains a tiered approach to the integral assessment. The methodology for the integral assessment of retail digitalization has been adapted to the retail industry of the Russian Federation. The results of an integral assessment of retail digitalization in the Russian Federation are presented, the ranking of digital technologies is performed, which allows to use the methodology to manage the industry development process under the conditions of a scientific and technological initiative and the irreversibility of digital transformation.*

**Keywords:** *Digitalization, Integral assessment, Retail*

## **1. INTRODUCTION**

The digitalization of the business space is a megatrend of the socio-economic development. Under the influence of digital technologies, all levels of economic managements are experiencing structural transformations, characterized by a high degree of dynamism, diversity and variation of the digitalization indicator factors throughout sectors of the economy and types of economic activity. The development of digital technologies, including in the service and retail sectors, helps to increase the efficiency and competitiveness through increasing business sustainability. Digitalization leads to a change in the trading paradigm, changes in technologies and business models, an increase in the role of digital customer service with a focus on personalized sales, and the introduction of innovations and progressive achievements of scientific and technological initiatives. The key role of digitalization in achieving socio-economic efficiency, the irreversibility of digital transformations, dynamism and a variety of indicators that characterize this process, requires an integral assessment of the level of retail digitalization. It should be noted that both in Russian and in other countries, there exists a substantial number of modern methodologies of assessing the level of digitalization, aimed at studying the main directions of digital transformation of socio-economic development in the spatial and temporal aspects. The methodologies of the comprehensive assessment of the level of digitalization are based on a multidimensional comparative analysis and the opinion of the expert community. The obtained results serve as a basis for global and national ratings of the achieved level of the digital development, technological advancement and digital receptivity of



countries. However, there are no studies assessing the deployment of digital technologies in the applied and industry aspects, including the achieved level of digitalization in retail, which determines the relevance of this study. The relevance of the study defines its objective. The objective of the study is to offer a methodology for an integral assessment of retail digitalization (integral assessment of the deployment of digital technologies in the industry aspect from case studies of retail).

## **2. METHODOLOGY**

The development of a methodology for the integral assessment of the retail digitalization level has prompted the necessity to consider methodological approaches to understanding the digitalization of the economy, to clarify this concept. The study of the digitalization process and its quantitative assessment in modern retail, in our opinion, is complicated due to the lack of coherent conceptual interpretation and unity of opinion in understanding the phenomenon of the digital economy. Bibliometric analysis of Russian and foreign works identified several original definitions of digital economy [1, 2, 6, 10, 11, 13]. The variety of interpretations is induced by the influence of a specific historical period, the level and trends of the technological development, and the direction of digital transformation of business processes [1]. Most researchers agree that the digital economy is an economy based on digital technologies. The digital economy should be considered as a set of all types of economic activities related, to varying degrees, to digital technologies [4]. The deployment of digital technologies largely depend on the achieved level of digitalization of the economy. Digitalization, in the broadest sense, involves the use of digital data in organizational and social processes, including economic activities [2]. This definition integrates e-business, e-Commerce, and the use of digital automation in key sectors, industries, and activities. Digitalization of business interactions has been initiated by the massive deployment and adaptation of digital technologies. Given the objective of this study, the conceptual provisions and methodological approaches to understanding digitalization proposed by specialists of CISCO – a leader in high-tech initiatives and digital solutions [7] are of a particular interest. According to the concept of CISCO, digitalization is the convergence of a significant number of scientific and technological digital innovations, using the opportunities and achievements of internet technologies [7]. Digitalization rests on new generation technologies – interpenetrating or end-to-end digital technologies, forming the potential of the so-called digital vortex. The digital vortex implies an imminent movement of various industries towards maximum digitization of business – added value chains and consumer value, including business interactions and the formation of new digital business models. Digital technologies are defined as electronic technologies for creating, processing, exchanging and transmitting information in digital or electronic form [14]. End-to-end or interpenetrating digital technologies are electronic technologies based on the deployment of software and hardware and systems, forming new markets, business models and business processes in all sectors of the economy. In this sense, end-to-end digital technologies reflect the advancement of scientific and technological development. The emergence of end-to-end digital technologies was induced by the three waves of technologies evolutionary development [5]. The first wave of digital technologies is associated with the development and harnessing of technologies for wired and wireless access to broadband internet, computerization and automation of processes (ERP, EDI, CRM, and others). The second wave reflects the active development of online or virtual platforms, social media, and cloud computing. The third wave is associated with the latest technological innovations, so called end-to-end or interpenetrating digital technologies. End-to-end digital technologies include big data technologies, the internet of things, robotics, touch control, mobile and platform technologies, augmented, virtual and hybrid reality, machine learning, artificial intelligence technologies and other new generation digital solutions.

Digital technologies of the first wave went through a long period of their development – from 1960 to 2000, the social and economic effects of their deployment were achieved in the period from 1990 to 2010. Digital technologies of the second wave have been developed since 1995 and up to the present, and the third wave started in 2010. Digital technologies of the third wave are just starting to manifest themselves and have a high potential for the socio-economic development. A range of well-known methods are used to assess the level of digitalization of the socio-economic development. Methodological approaches are based on the interpretation of multidimensional comparative analysis and experts' opinion. Experts are required to have high professional training, which largely depends on the subjective nature of their competence assessment and, therefore, determines the subjectivity of the results obtained and the results of rating generalization. Methods for evaluating digitalization are presented in the form of indexes (table 1).

Method	Developer	Economic meaning	Indicators, factors, and components
The index of readiness for a networked society ( <i>Networked Readiness Index</i> )	World Economic Forum, INSEAD International Business School	It describes the level of ICT development at the global level, taking into account the relationship between the level of ICT development and the economic well-being of the country.	A comprehensive indicator that reflects the availability of conditions for the development of ICT, the readiness of citizens and the state to use ICT, the level of ICT use in the public, commercial and public sectors, includes 53 parameters.
The ICT <i>development index</i> ( <i>ICT Development Index, IDI</i> )	International Telecommunication Union (ITU/ITU)	It studies the achievements of countries around the world in terms of determining their potential for the ICT development and the extent of their impact on the economic growth.	It includes 11 indicator factors, the main parameters of the assessment include the level of development of the ICT infrastructure, the intensity of ICT use and the potential for using ICT.
The index of information and communication technologies globalization ( <i>ICT Globalization Index</i> )	The Economist magazine	It shows the level of global ICT trade.	It is based on the study of 25 indicators that reflect openness to the trade in ICT sphere, to foreign investment into ICT, the globalization of developments, and the development of the ICT environment.
Digital economy and society index ( <i>DESI</i> )	Eurocommission	It characterizes the evolution and the level of digitalization of the economy and society.	It includes 5 main parameters: communication, human capital, internet use, digital technology integration, and e-government.
Digital Quotient	McKinsey	It reflects the achieved level of digital technologies deployment.	It is based on 24 indicators, assessing the level of digital technologies use in daily life and activities of the population, companies and government agencies, as well as the availability of ICT infrastructure and the development of digital innovations.
Global Connectivity Index (GCI)	Huawei	It assesses the level of development of end-to-end digital technologies and personnel (participants') digital competencies.	Broadband internet access, data centers, clouds, big data, internet of things; demand, supply, experience, and digital competence potential of subjects or personnel.

*Table 1: Methodological approaches to assessing the level of digitalization socio-economic development\**

\*Source: compiled by the author based on the official sites of index developers.

All of the above methods are mainly developed by foreign researchers. In Russia, the Rosatom state corporation has offered a tool measuring the national index of digital economy development. The national digital economy development index reflects the results of the application and impact of digital technologies on socio-economic development, the rating of regions and countries according to the following assessment criteria – digital infrastructure, digital business sector, information security, research and innovation business environment, human capital, government regulation measures [9]. The Digital Russia index developed by the Center for Financial Innovation and Cashless Economy of the SKOLKOVO Moscow School of Management is used as an additional or alternative way of measuring the level of digitalization [8].

Hence, well-known foreign and national methodologies of summarizing the impact of digital technologies and conditions for the development of the digital environment that assess the digitalization of socio-economic development differ. Each of the developed methodological approaches is an analytical way to measure the level of digital development, digital receptivity and the existing digital potential of countries and regions, mainly in spatial and temporal aspects. The scope of the methods and the frame of concepts are largely not systematized, do not have a clear specification and depend on the taxonomy and study objectives. Also, these methods do not provide the assessment of digitalization of the consumer market, services and trade.

### **3. THE STUDY RESULTS**

It was established that the scientists of the Institute for Statistical Studies and Economics of Knowledge (HSE) developed the Index of digitalization of business for an aggregate assessment of the prevalence of digital technology in the business sector [3]. The index is based on the main indicators that characterize the demand for digital technologies not only in spatial and temporal aspects, but also by types of economic activity, which distinguishes it from the above methodological approaches. The index rates the level of digitalization of business by country, including the intensity of digital technologies use in organizations [3]. However, this method does not involve indicators ranking, evaluating the contribution of each indicator factor to the overall result achieved, comparing it with the target or desired level, which requires improvement of the methodology. Today the role of integral assessment of digitalization in different industries, including in retail, is increasing, taking into account the development of digital technologies, their improvement, the potential and prospects of retailers' activities in the digital environment. This requires the formation of a modern information platform aimed at justifying the priorities for the deployment of certain types of digital technologies, assessing their impact on the achieved level of digitalization of business, forecasting on this basis the main directions of retail development in the digital environment and appropriate management decisions. Integral assessment of the retail digitalization level compared with the highest or reference level for scientific-technological initiatives becomes relevant and important. Integral assessment should be complemented by studying the influence of different types of digital technologies, their ranking, which may influence future activities planning and increase economic effectiveness. This task can be successfully solved with the help of analytical methods of system analysis and mathematical tools for structuring the problem. Analytical methods of system analysis are innovative and are represented by Prof. N. V. Shalanov Scientific School [12]. The author adapts analytical methods of system analysis and mathematical tools to the subject of the study with the new target settings, i.e. integral assessment of retail digitalization. The method of integral assessment of retail digitalization, developed by the author on the basis of analytical methods of system analysis and mathematical tools for structuring the problem, includes the following main stages.

*Stage 1.* Selection of indicator factors or indicators of retail digitalization, formation of a set of indicators. The main types of end-to-end or interpenetrating digital technologies are considered as indicators of retail digitalization:

- density of access to broadband internet for retailers per 100 organizations;
- the level of cloud computing use, %;
- level of use of RFID technology or internet of things technologies, %;
- the level of implementation of EPR systems, %;
- the share of retail organizations participating in the e-Commerce, %.

The generated set of indicators is open, so if necessary, it can be supplemented with other indicator factors that characterize the digitization process and the demand for digital solutions.

*Stage 2.* The target or reference values of the retail digitalization indicators are determined by expert assessment. Target or reference values may include: indicators specified in the documents for the programme or strategic development of the digital economy; the highest indicators achieved in global retail and others.

*Stage 3.* Calculation of the relative measure of achieving the target or reference value of demand for digital technologies by their types. The relative measure of achieving the reference or target value shows the ratio of the achieved level of demand for digital technologies in comparison with the target or reference level:

$$a_i = \frac{x_n^0}{x_n^*}; \quad (1),$$

where  $x_n^0$  is the actual value of the  $n$  indicator;

$x_n^*$  – reference or target value of the  $n$  indicator.

*Stage 4.* Determining the significance (weight) of each indicator in the integral assessment of retail digitalization:

$$b_i = \frac{a_i}{\sum_{i=1}^n a_i}; \quad (2),$$

*Stage 5.* Calculation of the integral assessment of retail digitalization or retail digitalization Index:

$$c_i = \frac{1}{n} \sum_{i=1}^n a_i; \quad (3).$$

Taking into account the coefficient values  $b_i$  in the model of integratal assessment of the retail digitalization level, it is possible to rank indicators by their importance and demand for digital technologies, and build a scheme for ranking priorities in the retail digital development.

The adaptation of this method to the new subject of the study allowed us to obtain the following results (table 2).

*Table following on the next page*

Indicator	Integral assessment coefficients of retail digitalization						Rating
	$x_n$	$x_n^0$	$x_n^*$	$a_i$	$b_i$	$b_i(\%)$	
Density of access to broadband internet for retailers per 100 organizations	$x_1$	91.3	100.0	0.913	0.281	28.1	1
Cloud computing use, %	$x_2$	36.2	50.0	0.724	0.223	22.3	3
RFID technology use, %	$x_3$	6.8	25.0	0.274	0.084	8.4	5
Implementation of EPR systems, %	$x_4$	34.5	45.0	0.767	0.236	23.6	2
Percentage of retail organizations participating in the e-Commerce, %	$x_5$	28.6	50.0	0.572	0.176	17.6	4
Total	-	-	-	3.250	1.000	100.0	-
Retail Digitalization Index	-	-	-	0.650	-	-	-

Table 2: Integral assessment of retail digitalization in the Russian Federation for 2018\*

\*Source: calculated by the author according to the statistics of the Institute for Statistical Studies and Economics of Knowledge of High School of Economics University [3].

$x_n^0$  – the actual value of the indicator  $n$ ;

$x_n^*$  – reference (target) value of the indicator  $n$ ;

$a_i$  – weight under the standardised values of indicators;

$b_i$  – significance of the indicator.

During the study period, the retail digitalization level in the Russian Federation was 65%, that is, the achieved state of deployment of digital technologies approached the reference level by 65%, which exceeds the level of the use intensity on average for economic activities. At the same time, the following indicators made the maximum contribution to the digitalization of retail: access of retail organizations to broadband internet (28.1%), EPR systems (23.6%), cloud technologies (22.3%). The smallest contribution was made by RFID or internet of things technologies (8.4%). Therefore, in the near future, retailers should expedite the deployment of the internet of things technologies, which are the basic technologies of modern development.

#### 4. CONCLUSION

The author's study provides tools for priority development of digital technologies by their types, comparison with the reference or desired level of retail digitalization, taking into account the influence of factors on the results obtained. An integral assessment of the retail digitalization level allows to identify the strengths and weaknesses of this process, measure the impact of digital technologies by their types on the retail, identify priorities for the deployment of certain digital technologies, justify the main directions of digitalization and management decisions that can form the prerequisites for innovative development of services and retail sectors on a digital basis.

**LITERATURE:**

1. Bukh, R., Heeks, R. (2018). Defining, Conceptualising and Measuring the Digital Economy. [Opredelenie, koncepcija i izmerenie cifrovoj jekonomiki] *Vestnik mezhdunarodnyh organizacij. (Global Development Institute working papers)*, 2018 (Vol. 13), pp. 143-172 (in English and Russian) Retrieved 05.03.2020 from: <https://docviewer.yandex.ru/view/1017072918/>
2. Brennen S., Kreiss D. (2014). Digitalization and Digitization. *Culture Digitally*. Retrieved 10.03.2020 from: <http://culturedigitally.org/2014/09/digitalization-and-digitization/>.
3. *Digitalization of business in Russia and abroad. [Cifrovizacija biznesa v Rossii i za rubezhom]*. (2019). Retrieved 12.03.2020 from: <https://issek.hse.ru/news/309213798.html>.
4. European Commission. (2013). *Expert Group on Taxation of the Digital Economy. Brussels: European Commission*. Retrieved 10.03.2020 from: [http://ec.europa.eu/taxation\\_customs/sites/taxation/files/resources/documents/taxation/gen\\_info/good\\_governance\\_matters/digital/general\\_issues.pdf](http://ec.europa.eu/taxation_customs/sites/taxation/files/resources/documents/taxation/gen_info/good_governance_matters/digital/general_issues.pdf) (accessed 1 June 2018).
5. Katz, R. (2017). *Socio-economic impact of digital transformation on the economy, ITU discussion paper, GSR-17.2017* Retrieved 10.03.2020 from: [https://www.itu.int/en/ITUD/Conferences/GSR/ Documents/ GSR2017/ Soc\\_Eco\\_impact\\_Digital\\_transformation\\_finalGSR.pdf](https://www.itu.int/en/ITUD/Conferences/GSR/ Documents/ GSR2017/ Soc_Eco_impact_Digital_transformation_finalGSR.pdf)
6. Lapidus, L. V. (2018). What is the digital economy and industry 4.0. Principles of transformation and prospects for business. [Chto takoe cifrovaja jekonomika i Industrija 4.0. Principy transformacii i perspektivy dlja biznesa] In L.V. Lapidua, *Prospects for the development of electronic business and e -Commerce: scientific papers [Perspektivy razvitija jelektronnogo biznesa i jelektronnoj kommercii: sbornik nauchnyh trudov]* M: Faculty of Economics of Lomonosov Moscow State University, pp. 4-15.
7. Loaks, J., Macaulay, J., Norona, E., Wade, M. (2018). *Digital vortex: How to win against didzhital-innovators their weapon. [Cifrovoj vihr'. Kak pobezhdat' didzhital-novatorov ih zhe oruzhiem]*. Moscow: Eksmo.
8. *Methodology for calculating the Digital Russia index for subjects of the Russian Federation. [Metodologija rascheta indeksa «Cifrovaja Rossija» subjektov Rossijskoj Federacii]*. (2018). Retrieved 10.03.2020 from: [https://www.plusworld.ru/wp-content/uploads/2018/10/SKOLKOVO\\_Digital\\_Russia\\_Report\\_Short\\_2018-10\\_ru-6.pdf](https://www.plusworld.ru/wp-content/uploads/2018/10/SKOLKOVO_Digital_Russia_Report_Short_2018-10_ru-6.pdf)
9. *National index of development of the digital economy: a pilot implementation. [Nacional'nyj indeks razvitija cifrovoj jekonomiki: Pilotnaja realizacija]*. (2018). Moscow: Rosatom State Corporation.
10. Shvab, K. (2016). *The Fourth industrial revolution. [Chetvjortaja promyshlennaja revoljucija]* Moscow: Eksmo.
11. Shnorr, Zh. P., Nagovicina, L. P. (2019). Determinants of the formation of innovative retail space in the digital economy. [Determinanty formirovaniya innovacionnogo prostranstva ritejla v uslovijah cifrovoj jekonomiki] *Vestnik Belgorodskogo universiteta kooperacii, jekonomiki i prava (Herald of Belgorod University of Cooperation, Economics and Law)*, 2019 (No. 6. (79)), pp. 52-71
12. Shalanov, N. V. (2008). *System analysis. Cybernetics. Synergetics: mathematical methods methods and models. Economic aspect. [Sistemnyj analiz. Kibernetika. Sinergetika: matematicheskie metody i modeli. Jekonomicheskie aspekty]*. Novosibirsk: NSTU.
13. Tapscott, D. (1996). *The Digital Economy: Promise and Peril in the Age of Networked Intelligence*. New York, NY: McGraw-Hill.
14. UNCTAD. (2015). *The Transformative Economic Impact of Digital Technology*. Retrieved 10.03.2020 from: [http://unctad.org/meetings/en/Presentation/ecn162015p09\\_Katz\\_en.pdf](http://unctad.org/meetings/en/Presentation/ecn162015p09_Katz_en.pdf)

## **A PROACTIVE APPROACH TO THE IDENTIFICATION OF DELIBERATE BANKRUPTCY OF ECONOMIC ENTITIES: ADVANTAGES AND LIMITATIONS**

**Mikhail Alekseev**

*Novosibirsk state University of Economics and management, (NINH), Russian Federation  
m.a.alekseev@nsuem.ru*

**Nina Vasiljeva**

*Novosibirsk state University of Economics and management, (NINH), Russian Federation  
vasilekns@mail.ru*

### **ABSTRACT**

*A feature of the modern Russian economy is the high proportion of economic entities that adapt to economic changes using non-traditional methods, in particular deliberate bankruptcy. The purpose of the study is to establish the advantages and limitations of a proactive approach to identifying deliberate bankruptcy of economic entities. The objectives of the study are a comparative description of the types of behavior of economic entities (bilateral / unilateral resolution of conflicts of interest through bankruptcy procedures, real, deliberate and fictitious bankruptcy, illegal actions in bankruptcy), disclosure of a proactive approach to identifying deliberate bankruptcy of economic entities and stages of its implementation, discussion of the results of identifying deliberate bankruptcy of economic entities in accordance with the proactive approach. In the process of establishing the advantages and limitations of a proactive approach to identifying deliberate bankruptcy of economic entities, such General scientific methods as analysis and synthesis, induction and deduction, modeling, as well as special methods of financial management (structural and dynamic analysis; analysis of financial coefficients; integrated financial analysis), statistical methods (qualitative statistical methods for studying homogeneous aggregates; correlation and regression analysis; time series analysis; construction of a probabilistic model) were used. The results establish the advantages and limitations of proactive approach to the identification of deliberate bankruptcy of economic entities formulated a number of hypotheses for further research in the aspect of identification of the strategies of behavior of economic subjects, based on the quality of signs of deliberate bankruptcy and the formation of a set of indicators for the study of objects.*

**Keywords:** *advantages and limitations of the proactive approach, bankruptcy, dishonesty, reactive and proactive detection of intentional bankruptcy, strategies of behavior of economic entities, willfulness*

### **1. INTRODUCTION**

Modern factors of the Russian economy – stagnation in the economy, problems in the credit sector, increased volatility of the ruble exchange rate, increased tax burden, etc. – determine the development and implementation by economic entities of various types of strategies of their behavior in the aspect of adaptation to turbulent economic changes, based on both traditional methods (improving performance, increasing net cash flow, attracting investment, etc.) and non-traditional methods (manipulation of accounting data, deliberate or fictitious bankruptcy, illegal actions in bankruptcy, raiding, price collusion, illegal actions in the implementation of public procurement). Among the listed strategies for overcoming economic instability, the strategy of deliberate bankruptcy of economic entities is highlighted. According to the data of the Supreme Arbitration Court of the Russian Federation, from 2010 to the present, from 30 to 40 thousand bankruptcy applications are received annually, however, in accordance with the reports on the work of arbitration courts of the subjects of the Russian Federation on bankruptcy

cases, the financial recovery procedure was applied in an extremely small number of cases – less than 1% [3, 14]. According to representatives of a number of scientific schools, research and educational centers established under the Ministry of internal Affairs of the Russian Federation, the low percentage of economic entities with rehabilitation procedures in bankruptcy proceedings is due to the underdevelopment of the Russian Institute of bankruptcy and violations of legislation in the implementation of the bankruptcy strategy [2, 5]. In the system of legal resolution of conflicts in the performance of debt obligations by economic entities, in addition to actual bankruptcies, deliberate bankruptcies of economic entities as a result of the implementation of the selfish goals of owners or top management are quite widespread. Under the current reactive approach to identifying deliberate bankruptcy of economic entities [4, 6, 7, 8, 9, 11, 12, 16, 17] external stakeholders (bona fide creditors) inevitably incur losses of assets (capital). The inadequacy of a reactive approach to identifying deliberate bankruptcy of economic entities to the interests of external stakeholders requires an appropriate response at the micro level. The authors suggest shifting the research of the problem towards a proactive approach to identifying deliberate bankruptcy of economic entities.

## **2. PROACTIVE APPROACH TO DETECTING DELIBERATE BANKRUPTCY OF ECONOMIC ENTITIES**

A proactive approach to detecting deliberate bankruptcy of economic entities is to identify unscrupulous debtors in advance (before the start of bankruptcy proceedings) with the establishment of signs of unscrupulous debtors that can be identified by external stakeholders in conditions of limited access to confidential financial and extra-financial sources of information. This approach is based on a combination of statistical methods for predicting bankruptcy and methods for identifying qualitative signs of deliberate bankruptcy of economic entities – placing "red flags" using modern information technologies. The proactive approach is implemented in four stages (figure 1).

Phase one. Establishing the presence of qualitative signs of deliberate bankruptcy of economic entities through the formation of training sets of economic entities "Economic entities-deliberate bankrupts", "Active economic entities of solvent and stable financial condition". The method of "information availability" and the method of placing "red flags" are used, according to which the presence of qualitative signs of deliberate bankruptcy of subjects is determined by the appropriate conclusion of the arbitration Manager (SCREEN). The method of constructing an integral indicator for assessing the probability of intentional bankruptcy is implemented at the second stage of the approach and includes the following steps. 1. Formation of a set of financial indicators that quantitatively characterize the state of entities from various sides and are calculated on the basis of accounting reports - in this case, we are based on the methods of horizontal-vertical analysis of the balance sheet, analysis of financial and economic indicators used in current approaches to identifying deliberate bankruptcy [4, 6, 7, 8, 9, 11, 12, 16, 17], as well as on the traditional approach to predicting bankruptcy of subjects E. Altman, R. Lees, D. Chesser, R. Taffler, G. Springate, J. Conan-M.Golder, D. Olson, D. Fulmer, E. Altman-Sabato [1, 10, 13, 15]. Thus, in assessing the likelihood of deliberate bankruptcy use the following groups of financial indicators of economic entities: measurement of assets and liabilities (12 indicators); indicators of asset structure (10 indicators); indicators of the structure of sources of financing activities (9 indicators); liquidity indicators (11 indicators); indicators of solvency (9 indicators); indicators of business activity (9 indicators); profitability indicators (19 indicators).



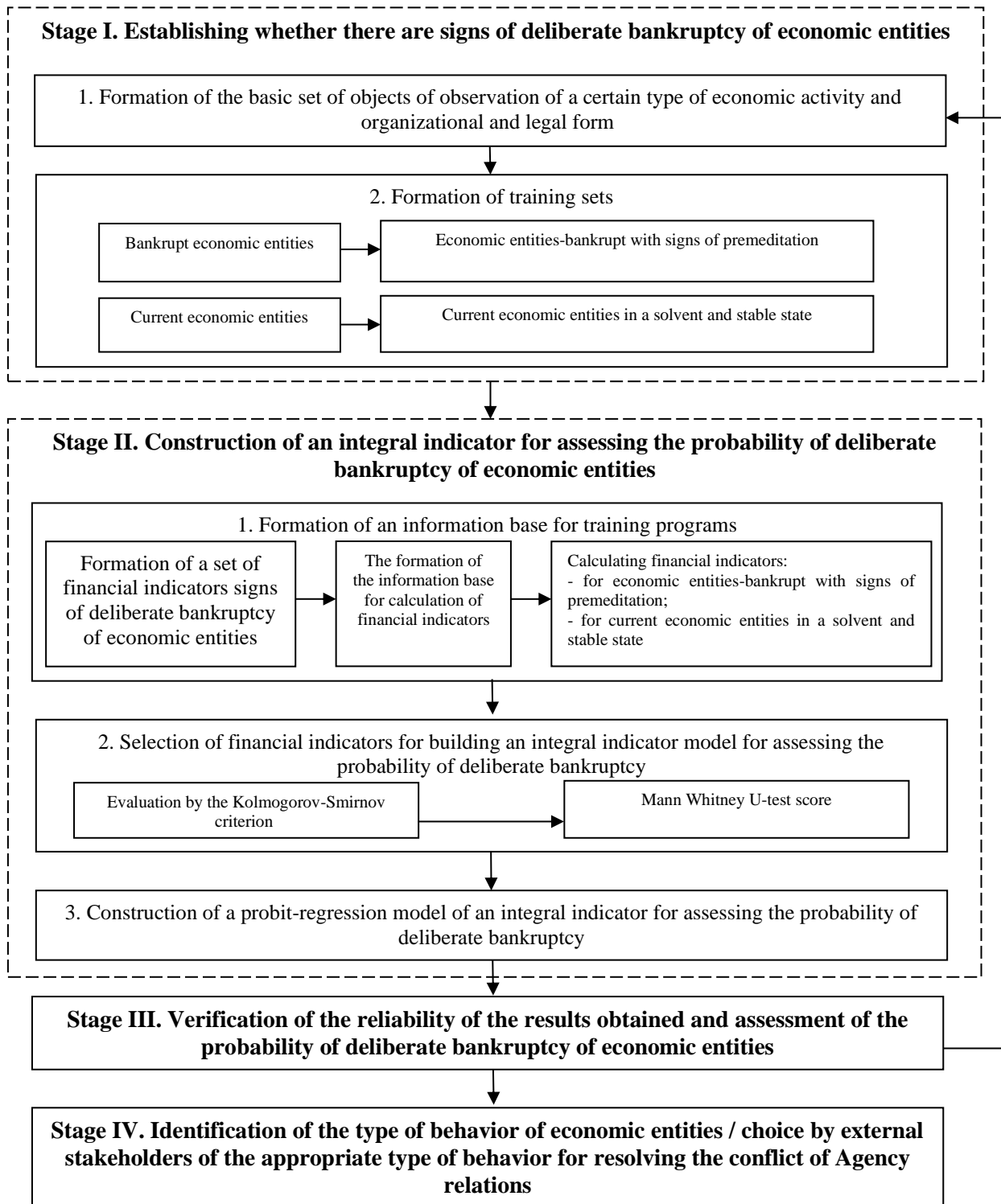

*Figure 1: Stages of implementing a proactive methodological approach to identifying deliberate bankruptcy of economic entities*  
(Source: worked out by the authors)

2. Formation of an information base on training sets using a method of contrasting historical data and the actual state, which consists in establishing a time lag that reflects the pre-emergence of signs of deliberate bankruptcy of the beginning of proceedings on the bankruptcy of an economic entity. The study adopted a two-year time lag separating:

- in relation to the training set "Economic entities-deliberate bankruptcy" - the period of identification of quantitative signs of deliberate bankruptcy from the period of introduction of the monitoring procedure;

- in relation to the training set "Active economic entities of solvent and stable financial condition" - the period of identification of quantitative signs of deliberate bankruptcy from the last reporting period.

3. Calculation of financial indicators for each training set.

4. Selection of financial indicators for building an integral indicator model for assessing the probability of deliberate bankruptcy. Financial indicators that have the greatest semantic value in determining the financial condition of economic entities are selected:

- exclude indicators that characterize the same aspects of the activities of economic entities,
- indicators should identify and separate existing financially stable and solvent economic entities from economic entities that are deliberately bankrupt,
- indicators should be independent of each other.

Indicators with these characteristics are identified using Kolmogorov-Smirnov and Mann-Whitney statistical tests.

5. Construction of the final formula of the integral indicator for assessing the probability of deliberate bankruptcy. The probit model of binary response is used as a tool for developing a statistical model of an integral indicator for assessing the probability of deliberate bankruptcy of economic entities. The research choice is due to the fact that all binary response models differ radically from classical discriminant analysis and logit analysis in the following characteristics: they allow us to take into account the nonlinear dependence of the output value on the input factors; determine the specific probability of bankruptcy of organizations, i.e. there are no so-called zones of uncertainty.

Each of the selected indicators is evaluated, i.e. their discriminatory weight is determined. Then, based on mathematical and econometric methods, a probit regression model is constructed that links the probability of the risk of intentional bankruptcy of economic entities and the main financial indicators of their activities. The parameters of the probit regression function are determined using the formula (1).

$$Z = \beta_0 + \beta_1 X_1 + \beta_2 X_2 + \dots + \beta_i X_i, \quad (1)$$

Z – variable of the probit regression function;

$\beta_i$  - independent member;

$X_i$  – value of the i-th indicator.

Construction of the final formula of the integral indicator, which will reflect the pattern between deliberate bankruptcy and the selected financial indicators, is carried out using the STATISTICA program.

The goal of the third stage is to assess the predictive power of the built probit-regression model of the integral indicator of the probability of deliberate bankruptcy of economic entities.

During the fourth stage, external stakeholders choose the appropriate type of behavior in relation to the studied economic entities.

Processing of information arrays, calculations and building models were performed using the application package Statistika12, as well as the information database of Russian companies "SCREEN".

The proposed proactive approach was tested in relation to the subjects of three types of economic activities – "Agriculture, forestry, hunting, fishing and fish farming", "Construction", "wholesale trade, except for wholesale trade in motor vehicles and motorcycles" – included in the category of economic activities with the highest activity of company bankruptcies in 2017-2018. Probit-regression models for estimating the probability of deliberate bankruptcy of entities are constructed. Table 1 shows the results of verification of their implementation.

Intervals of values for the probability of deliberate bankruptcy	Agriculture, forestry, hunting, fishing and fish farming		Construction		Wholesale trade, other than wholesale trade in motor vehicles and motorcycles	
	The number of economic entities	The proportion of economic entities, %	The number of economic entities	The proportion of economic entities, %	The number of economic entities	The proportion of economic entities, %
[0-0,1]	804	29,91	1252	41,69	7016	25,51
(0,1-0,2]	114	4,24	100	3,33	2512	9,13
(0,2-0,3]	69	2,57	96	3,20	2116	7,69
(0,3-0,4]	77	2,86	80	2,66	1655	6,02
(0,4-0,5]	56	2,08	72	2,40	1419	5,16
(0,5-0,6]	75	2,79	103	3,43	1430	5,20
(0,6-0,7]	86	3,20	70	2,33	1378	5,01
(0,7-0,8]	110	4,09	69	2,30	1317	4,79
(0,8-0,9]	154	5,73	70	2,33	1163	4,23
(0,9-1]	1143	42,52	1091	36,33	7494	27,25
Итого	2688	100,00	3003	100,00	2750	100,00

*Table 1: Results of verification of the implementation of the probit-regression model for estimating the probability of intentional bankruptcy according to 2017 (Source: worked out by the authors)*

Using the constructed integral indicator of assessment of the probability of deliberate bankruptcy within the proactive approach the actual set of objects of observation generally divided into three groups of economic actors with different degrees of probability of committing a deliberate and intentional action to achieve its insolvency in 2018-2019.: a group of subjects with a high degree of probability of deliberate bankruptcy – (0,9-1], with a low probability of deliberate bankruptcy – [0-0,1], with the uncertainty of intentions on business continuity – (0,1-0,9]. Grouping economic entities by the degree of probability of intentional bankruptcy allows external stakeholders to form their judgment on the intentions of continuity of their behavior in the period 2018-2019 in advance, at the time of 2017, when the entities have not yet entered bankruptcy proceedings.

### **3. ADVANTAGES AND LIMITATIONS OF A PROACTIVE APPROACH TO DETECTING DELIBERATE BANKRUPTCY OF ECONOMIC ENTITIES**

The proactive approach has the following advantages.

1. Using the method of placing "red flags" in identifying qualitative signs of deliberate bankruptcy of economic entities ensures that the approach is accessible to external stakeholders.
2. The use of statistical tests in the selection of financial indicators that maximally distinguish the objects of observation of the two training sets causes a formalized selection of financial indicators that characterize the deliberate bankruptcy of economic entities.
3. The construction of an integral indicator for assessing the probability of deliberate bankruptcy of economic entities avoids inconsistencies in the calculation of financial indicators of the state of economic entities.

4. Assessment of the probability of deliberate bankruptcy of economic entities allows external stakeholders to assess their behavior in advance in the aspect of continuity / early termination of economic activities.

At the same time, the proactive approach is characterized by some limitations.

1. The proposed proactive approach does not allow us to identify other strategies of behavior of economic entities (table 2), except for the strategy of deliberate bankruptcy.

Criteria comparisons	Strategies for continuing operations			The strategy of premature termination of activities		
	Bilateral resolution of conflicts of interest through bankruptcy procedures	Unilateral resolution of conflicts of interest through bankruptcy procedures	Fictitious bankruptcy	Real bankruptcy	Wrongful actions in bankruptcy	Deliberate bankruptcy
Type of strategy	Unintentional, conscientious	Deliberate, conscientious	Willful, dishonest	Unintentional, dishonest	Willful, dishonest	
Financial condition of an economic entity	Unstable or crisis state	Normal financial stability	False insolvency with normal financial stability	Real unstable or crisis state	Real unstable or crisis state	Deliberate unstable or crisis financial state
Goal	Removing the subject from an unstable or crisis state and continuing economic activity	Receipt by economic entities of a deferred payment of their obligations from creditors		Liquidation of an economic entity	- Enrichment of top management / owners of the debtor - Preserving the capital of the debtor's owners	Enrichment of top management / owners of the debtor
Ways to achieve the goal in the aspect of bankruptcy proceedings	Supervision, financial recovery, external management, settlement agreement	Supervision		Competitive proceeding	External management, bankruptcy proceedings	Competitive proceeding
Initiators	Owners, top management, creditors	Owners, top management	Owners, top management	Owners, top management, creditors	Owners, top management, arbitration managers, third parties (for example, competitors)	Owners, top management
Development and implementation	Before the start of bankruptcy proceedings				In the process of production on business about bankruptcy	Before the start of bankruptcy proceedings
The result of the implementation	Overcoming an unstable or crisis state	The elimination of cash shortages in cash flow		Inability to overcome an unstable or crisis state and transition to the status of implementation of the bankruptcy procedure with the repayment of obligations	Inability to overcome an unstable or crisis state and transition to the status of implementation of the bankruptcy procedure without repayment of obligations	
Implications for external stakeholders	Without causing damage	Without causing damage	Causing major damage	Causing damage	Causing major damage	Causing major damage
Regulatory document	Federal law «On insolvency (bankruptcy)»	1. Criminal code, article 197 2. Federal law «On insolvency (bankruptcy)»		Federal law «On insolvency (bankruptcy)»	1. Criminal code, article 195 2. Federal law «On insolvency»	1. Criminal code, article 196 2. Federal law «On insolvency (bankruptcy)»

*Table 2: Comparative characteristics of behavior strategies of economic entities (Source: worked out by the authors)*

2. The Proactive approach is based on using as "red flags" the conclusion of the arbitration Manager on the presence of signs of deliberate bankruptcy of economic entities under the following condition (based on the results of empirical research): the basic set of objects of observation used in the construction of training sets is characterized as a large data set, the organizational and legal form of companies-open joint stock companies (JSC), public joint stock companies (PJSC), non – public joint stock companies (NPJSC), closed joint stock companies (CJSC).

Empirical studies have shown that the frequency of occurrence of economic entities with the conclusions of the arbitration Manager about the presence of signs of deliberate bankruptcy in the basic set of objects of observation decreases in the sequence:

- 1) large data set, JSC, PJSC, NPJSC, CJSC;
- 2) large data set, LLC;
- 3) small data set, JSC, PJSC, NPJSC, CJSC;
- 4) small data array, LLC.

This circumstance leads to an increase in the complexity / inability to select the objects of observation in the necessary number for the formation of the training set "Economic subjects-deliberate bankrupts".

3. A proactive approach to the identification of deliberate bankruptcy of economic entities, as well as economic-legal and economic-information-based approaches based on the use of financial models for the formation of a set of financial indicators for the study of objects, including the classical terms of dynamics and structure of assets and liabilities of the entity of liquidity, solvency, business activity and profitability.

However, the question remains debatable: whether the classical financial indicators of the accounting model of analysis reflect the existing schemes of deliberate and unfair bringing of economic entities to insolvency. According to researchers, the accounting model of analysis allows us to identify the consequences of insolvency, but not its causes [7]. Researchers also discuss the issue related to the identification of classical financial indicators as indicators of premeditation to bring the subject to insolvency, even though the relevant conditions are established (illegal transactions, corresponding "red flags").

#### 4. CONCLUSION

Taking into account the established limitations of a proactive approach to detecting deliberate bankruptcy of economic entities, the following recommendations are made.

1. Identification of strategies of behavior of economic entities. The results of the study showed that strategy of behavior of economic entities with different goals and ways to achieve it, the initiators, stages of development and implementation, forms of implementation, etc., that require the use of their detection methodologies, different monitoring objects, methods of research and sequence of their use. Thus, in particular, to detect deliberate bankruptcy of economic entities using qualitative statistical methods of research of the set of objects it is necessary to build training sets "of Economic actors – the deliberate bankrupt" Operating economic entities are solvent and stable state"; to identify the real bankruptcy of economic entities is necessary to change the training set "Economic actors – deliberate bankrupt" training set "of Economic actors – the real bankrupt." In this regard, the authors suggest the development of a proactive approach:

- methods for detecting real bankruptcy of economic entities based on the construction of a pair probit regression of the probability of real bankruptcy of economic entities;
- methods for estimating the probability of three possible States of economic entities (active economic entity, real bankrupt, deliberate bankrupt), based on the transition from paired to ordinal probit regression.

In the process of identifying illegal actions by external stakeholders in bankruptcy, taking into account the specifics of this strategy of behavior of economic entities, it is recommended to shift the study from identifying the types of behavior of unscrupulous debtors to identifying the types of behavior of arbitration managers and third parties. In this regard, it is recommended to develop:

- methodological approach to identifying the type of behavior of arbitration managers (assessment of the probability of deliberate, unfair abuse of their powers by arbitration managers);
- methodological approach to detecting collusion of arbitration managers (assessment of the probability of collusion of an unfair debtor with arbitration managers, assessment of the probability of collusion of arbitration managers and third parties (competitors)).

2. Accounting for qualitative signs of deliberate bankruptcy. The authors suggest using an additional / alternative "red flag" statement/act on the recognition of the debtor's transaction as invalid (table 3), which is explained by the following arguments.

Characteristics of the basic set of objects of observation		Organizational and legal form of objects of observation	
		JSC, PJSC, NPJSC, CJSC	LLC
Volume of the data array	Large data set (more than 5000 objects of observation)	Conclusion of the arbitration Manager on the presence of signs of deliberate bankruptcy of subjects	1. Conclusion of the arbitration Manager on the presence of signs of deliberate bankruptcy of subjects 2. Statement/act declaring the debtor's transaction invalid
	Small data set (up to 5000 objects of observation)	1. Conclusion of the arbitration Manager on the presence of signs of deliberate bankruptcy of subjects 2. Statement/act declaring the debtor's transaction invalid	Statement/act declaring the debtor's transaction invalid

*Table 3: Conditions for using "red flags" in detecting deliberate bankruptcy of economic entities (Source: worked out by the authors)*

In order to identify signs of deliberate bankruptcy, in accordance with the Decree of the Government of the Russian Federation of 27.12.2004 N 855 "on approval of Temporary rules for verification by the arbitration Manager of the presence of signs of fictitious and deliberate bankruptcy", the debtor's transactions are analyzed for their compliance with the legislation of the Russian Federation, as well as market conditions. In this regard, the presence of such a document as a statement / act on the recognition of an organization's transaction as invalid, in our opinion, under certain conditions (for example, the organization is in liquidation) can be considered as a sign of deliberate bankruptcy of the organization.

3. Formation of a set of indicators for the study of objects of observation. Taking into account these limitations of the proactive approach to identifying deliberate bankruptcy of economic entities associated with the formation of a set of financial indicators for the study, the authors make the following recommendations (table 4).

The qualitative-integral methodological approach can be developed in part:

- development of a method for constructing an integral indicator for assessing the probability of deliberate bankruptcy of economic entities based on a market analysis model;

- development of a methodology for constructing an integral indicator for assessing the probability of deliberate bankruptcy of economic entities based on special indicators for assessing the degree of manifestation of qualitative signs of deliberate bankruptcy.

Comparison criterion	Qualitative-integral methodological approach			Quantitatively, the integrated methodological approach
	Method of constructing an integral indicator «Accounting model of analysis»	Method of constructing an integral indicator «Market model of analysis»	Method of constructing an integral indicator «Indicators for assessing the degree of manifestation of qualitative signs of deliberate bankruptcy»	
Methods of research of a set of objects of observation	Qualitative statistical methods			Quantitative statistical methods
Accounting for qualitative signs of deliberate bankruptcy	Building training sets		Special indicators	Special indicators
Training set	(1) Economic entities-deliberate bankrupts (2) Active economic entities in a solvent and stable state		(1) Bankrupt Economic entities (2) Active economic entities in a solvent and stable state	---
Accounting for quantitative signs of deliberate bankruptcy	Traditional financial analysis indicators	Cost indicators of the analysis	Traditional financial analysis indicators/ Cost indicators of the analysis	Traditional financial analysis indicators/ Cost indicators of the analysis
Conditions for identifying financial indicators as indicators of deliberate insolvency	Red flags - conclusion of the arbitration Manager on the presence of signs of deliberate bankruptcy, acts on the recognition of the transaction as invalid		---	---
Status	Empirically tested	Hypothetical	Hypothetical	Hypothetical
Advantages	- ease of implementation - availability of information sources	- ease of implementation	- availability of information sources	- availability of information sources
Limitations	- see the text above	- unavailability / lack of information	- labor intensity	- labor intensity

*Table 4: Proactive detection of deliberate bankruptcy of economic entities  
(Source: worked out by the authors)*

The qualitative-integral methodological approach is based on the use of qualitative statistical methods in the study of a set of objects of observation and the construction of an integral indicator for assessing the probability of deliberate bankruptcy of economic entities. The development of a method for constructing an integral indicator for assessing the probability of deliberate bankruptcy of economic entities based on a market analysis model involves changing the composition of the set of indicators for the analysis of objects of observation from classical

financial indicators to cost indicators (table 4). Development of methods of building the integral indicator of probability of deliberate bankruptcy of economic entities on the basis of special indicators for assessing the degree of manifestation of quality signs of deliberate bankruptcy involves a change in the composition of a combination of indicators the analysis of monitoring objects with classical financial indicators specific indicators. It is possible to develop a quantitative-integral methodological approach. The quantitative-integral methodological approach is based on the use of quantitative statistical methods in the study of a set of objects of observation and the construction of an integral indicator for assessing the probability of deliberate bankruptcy of economic entities. The formulated recommendations for the development of a proactive methodological approach to identifying deliberate bankruptcy of economic entities necessitate further theoretical, methodological, and empirical research.

#### LITERATURE:

1. Altman E. I. (2000). Predicting financial distress of companies: Revisiting the Z-score and Zeta models. *Handbook of Research Methods and Applications in Empirical Finance*, No. 9, pp.1-54.
2. Chesnokov A. A. (2013). Nekotorye osobennosti dokazyvaniya faktov prednamerennogo bankrotstva [Some features of proving the facts of intentional bankruptcy] *Altaiskii yuridicheskii vestnik - Altai legal Bulletin*, No. 1 (1), pp. 34-39.
3. Edinyi federal'nyi reestr yuridicheskii znachimykh svedenii o faktakh deyatel'nosti yuridicheskikh lits, individual'nykh predprinimatelei i inykh sub"ektov ekonomicheskoi deyatel'nosti [Unified Federal register of legally significant information on the facts of activity of legal entities, individual entrepreneurs and other economic entities]. Retrieved 07.11.2019 from <https://fedresurs.ru/helps/news>
4. Lazareva O. S., Nelyubov N. G. (2018). Bankrotstvo yuridicheskikh lits. Fiktivnoe i prednamerennoe bankrotstvo [Bankruptcy of legal entities. Fictitious and deliberate bankruptcy]. *Alleya nauki – Alley of science*, T. 1, No. 6, pp. 376-382.
5. Leonov A. I. (2015). Ispol'zovanie organami vnutrennikh del ekonomicheskoi informatsii pri vyyavlenii prednamerennykh bankrotstv [The use of economic information by the internal Affairs bodies in the detection of intentional bankruptcies] *Ekonomika, pravo, obrazovanie: regional'nyi aspekt. Sbornik nauchnykh trudov IX mezhvuzovskoi nauchno-prakticheskoi konferentsii - Economics, law, education: regional aspect. Proceedings of the IX interuniversity scientific and practical conference*, pp. 288-292.
6. Lvova N. A. (2016). Prednamerennoe bankrotstvo rossiiskikh predpriyatii: institutsional'nye predposylki i finansovye priznaki [Deliberate bankruptcy of Russian enterprises: institutional prerequisites and financial characteristics] *Menedzhment i biznes-administrirovaniye - Management and business administration*, No. 4, pp. 98-105.
7. Lvova O. A. (2018). Rol' instrumentariya finansovykh rassledovaniy v protsedurakh bankrotstva kompanii [The role of financial investigation tools in bankruptcy procedures of companies] *Vestnik Instituta ekonomiki Rossiiskoi akademii nauk - Bulletin Of the Institute of Economics of the Russian Academy of Sciences*, No. 2, pp. 125-140.
8. Morodumov R. N., Markov S. E. (2017). Provedenie ekonomicheskoi ekspertizy pri rassledovanii prednamerennykh bankrotstv [Conducting an economic expert examination in the investigation of deliberate bankruptcy] *Lichnost', pravo, gosudarstvo - The Identity, law, government*, No. 4, pp. 140-151.
9. Nabeeva N. G. (2016). Finansovye skhemy i sposoby realizatsii prednamerennykh bankrotstv v praktike rossiiskogo biznesa [Financial schemes and methods of realization of intentional bankruptcies in the practice of Russian business] *Vestnik Tomskogo gosudarstvennogo universiteta – Ekonomika. Bulletin of Tomsk state University. Economy*, No. 4 (36), pp. 86-94.



10. Ohlson J. A. (1980). Financial Ratios and probabilistic prediction of bankruptcy. *Journal of Accounting Research*, Vol.18, No. 1, pp.109-131.
11. Pimenov D. M. (2016). Tselesoobraznost' sozdaniya edinoi metodologii vyyavleniya priznakov prednamerennykh i fiktivnykh bankrotstv [Expediency of creation of uniform methodology of identification of signs of deliberate and fictitious bankruptcies] *Analiz i sovremennye informatsionnye tekhnologii v obespechenii ekonomicheskoi bezopasnosti biznesa i gosudarstva: Sbornik nauchnykh trudov i rezul'tatov sovmestnykh nauchno-issledovatel'skikh proektov. REU im. G.V. Plekhanova, Moskva. - The analysis and modern information technologies in ensuring economic safety of business and the state: Collection of scientific papers and results of joint research projects. REU them. G. V. Plekhanov, Moscow*, pp. 319-323.
12. Postanovlenie Pravitel'stva RF ot 25.06.2003 N 367 «Ob utverzhdenii Pravil provedeniya arbitrazhnym upravlyayushchim finansovogo analiza» [The decree of the RF government of 25.06.2003 No. 367 "On approval of Rules of the financial analysis by an arbitration manager"] *Spravochno-pravovaya sistema Konsul'tantPlyus - Legal-reference system ConsultantPlus*
13. Springate, Gordon L. V. (1978). Predicting the Possibility of Failure in a Canadian Firm. *An Unpublished M. B. A. Research Project. Simon Fraser University*.
14. Sudebnyi departament pri Verkhovnom sude Rossiiskoi Federatsii [Judicial Department at the Russian Federation Supreme court]. Retrieved 07.11.2019 from <http://www.cdep.ru/index.php?id=79&item=4757>
15. Taffler R. (2007). Twenty-five Years of the Taffler Z-score model: Does It Really Have Predictive Ability? *Accounting and Business Research*, No. 12, pp.1-43.
16. Zemskov, V. V., Solovyov A. I., Solov'ev S. A. (2017). Modeli otsenki riska nesostoyatel'nosti (bankrotstva): istoriya i sovremennost' [Insolvency (bankruptcy) risk assessment models): history and modernity] *Economica. Nalogi. Pravo - Economics. Taxes. Law*, T. 10, No. 6, pp. 91-100.
17. Zuy I. V. (2017). Otvetstvennost' za prednamerennoe bankrotstvo v rossiiskom zakonodatel'stve [Responsibility for intentional bankruptcy in Russian legislation] *Evraziiskaya advokatura - Eurasian Advocacy*, <https://elibrary.ru/contents.asp?id=34531435> No. 4 (29), pp. 101-103.

# ECONOMIC, SOCIAL, AND INSTITUTIONAL DETERMINANTS OF DOMESTIC CONFLICT IN FRAGILE STATES

**Syed Muhammad All-e-Raza Rizvi**

*Université Clermont Auvergne (UCA), Ecole d'Économie, Clermont-Ferrand, France  
allerazarizvi@gmail.com*

**Marie-Ange Veganzones-Varoudakis**

*Université Clermont Auvergne (UCA), CNRS, CERDI, Clermont-Ferrand, France  
veganzones@aol.com*

## **ABSTRACT**

*In this article, we use Fixed Effect Poisson Regression (FEPR) with robust standard errors to study the economic, social, and institutional determinants of domestic conflict in 58 fragile states over the period 2004 to 2017. We show that effective institutions (measured by judicial effectiveness) and higher incomes would help reduce conflict in these countries. By contrast, democracy would not mitigate violence, democratic experiences generally showing an increase in conflicts in fragile countries. It would also seem that the development of human capacity does not contribute to the reduction of conflict. This would imply that fragile states first improve the social, economic and institutional conditions of their populations before they benefit from political reforms and of education. The same would be true for economic reforms in the context of globalization, which would not help reduce violence in fragile countries either.*

**Keywords:** *Conflict, Fragile Countries, Economic Reforms, Education, Institutions, Democracy*

## **1. INTRODUCTION**

Over the past decade, the Uppsala Conflict Data Program (UCDP) has recorded an upward trend of violence in the world. In addition to human suffering, civil strife causes considerable damage to economies due to its negative effects on public spending, infrastructure, political stability, foreign direct investment, trade, and growth. As a result, while extreme poverty is declining worldwide, it is increasing in fragile countries affected by conflicts. If left unchecked, nearly half of the world's poor will live in fragile countries facing conflict situations by 2030 (World Bank, 2018). Several studies have suggested that armed violence occurs most of the time in countries which have poor social, economic, and political conditions. Collier (2007) states that “seventy-three percent of people of the bottom billion have recently been through a civil war or are still in one”. Stewart (2002) notes that most of the economies with the lowest level of human development have been confronted with civil wars over the last three decades. Lai (2007) states that low income levels and high income inequality are positively associated with terrorism. Countries with fragile political conditions are also more vulnerable to domestic violence. Coggins (2015) found that political collapse has a positive correlation with armed conflicts. Newman (2007) and Piazza (2008) confirm that it is easier for extremist groups to establish their organizations in failed states. Economic growth and wealth, however, are not always a source of peace and non-violence in fragile countries, as Caruso and Schneider (2011) explain in their theory of “immiserizing modernization”. When growth changes the distribution of wealth, as described by Olson (1963), it can lead to social and political unrest fueled by groups of people who lose from the change. If perceived as a threat, economic reforms may lead to civil unrest as well, as explained by Freytag et al (2011) for globalization. Gur (1970) confirms that when individuals feel economically disadvantaged, they may be willing to fight to change their situation. When inequalities create grievances among the poor, recruiting them to fight the government, in the hope of a better life, becomes easy for extremist organizations.

Rational Choice theory provides an explanation for the emergence of civil conflicts in fragile countries by suggesting that human actions are based on the "calculation of risk, cost and incentive" (Teydas et al, 2011). Similarly, the "opportunity-based approach" indicates that the most important factor in becoming a rebel is the expectation of personal gain or reward (Teydas et al, 2011). Collier and Hoeffler (2004) argue that "rebellion can occur when lost income is low". Freytag et al (2011) suggest that if the opportunity cost of the use of illegal force is high, people will choose material wealth rather than mental reward. In this study, we explore the social, economic, and institutional determinants of domestic conflict in 58 fragile countries. We use the annual number of conflict-based domestic incidents processed from the Global Terrorism Database (GTD) as a proxy for internal conflict<sup>1</sup>. We analyze the development of violence for 4 different groups of countries from 2004 to 2017: (i) Total sample of fragile countries, (ii) Islamic fragile states, (iii) fragile countries with more than one main religion<sup>2</sup>, (iv) States affected by major conflicts<sup>3</sup>. These countries were selected from the Fund for Peace (FFP) database, which publishes annually a fragility index for 178 countries around the world<sup>4</sup>. In the empirical part of the study, we show that effective institutions (measured by judicial effectiveness) and higher incomes are well correlated with a reduction of conflicts in the most fragile countries. However, democracy would not seem to mitigate violence, democratic experiences generally showing an upsurge of fighting. It would also seem that the development of human capital does not contribute to the reduction of violence, which would imply that fragile states first improve their social, economic and institutional conditions before they can benefit from the fruits of political reforms and of education of populations. The same conclusion could be drawn for economic reforms in the context of globalization, as trade liberalization does not seem to help reduce violence in fragile countries either. These results are important in the context of the increasing number of conflicts around the world, which undermine progress in improving living standards and reducing poverty in fragile countries (World Bank, 2018). They help to understand the difficulties faced by governments in reducing violence and point to ways for a progressive approach to long-term conflict resolution. The rest of the article is organized as follows. Section 2 presents our model of conflict and defines the variables used in the analysis and the data sources. Section 3 highlights the methodological aspects related to our estimates of violence. Section 4 presents the results of the empirical analysis for our various samples of countries. The last section concludes with our main findings and policy recommendations.

## 2. PRESENTATION OF THE MODEL AND OF THE VARIABLES

### 2.1. The Model

The equations used to study the determinants of conflict in fragile states are as follows:

$$Conf_{it} = \alpha_0 + \alpha_1 (GDPc_{it}) + \alpha_2 (Edum_{it}) + \alpha_3 (Open_{it}) + \alpha_4 (Pop_{it}) + \alpha_5 (Contracts_{it}) + \alpha_6 (Demo_{it}) + \varepsilon_t \quad \text{Eq (1)}$$

$$Conf_{it} = \alpha_0 + \alpha_1 (GDPc_{it}) + \alpha_2 (H_{it}) + \alpha_3 (Open_{it}) + \alpha_4 (Pop_{it}) + \alpha_5 (Contracts_{it}) + \alpha_6 (Demo_{it}) + \varepsilon_t \quad \text{Eq (2)}$$

Where *Conf* is the count data variable for measuring conflict, *GDPc* the logarithm of real GDP per capita, *Edum* the average years of education, *H* the human capital index, *Open* the indicator of trade openness, *Pop* the logarithm of population, *Contracts* the proxy for judicial

<sup>1</sup> <https://www.start.umd.edu/data-tools/global-terrorism-database-gtd> .

<sup>2</sup> Countries where more than 10% of people belong to a different religious group

<sup>3</sup> Countries having had at least 5 conflict-related incidents per year for at least half of the period studied

<sup>4</sup> <https://fragilestatesindex.org/data/> .

effectiveness, and *Demo* the democracy variable.  $i$  is the cross sections index,  $t$  the time dimension and  $\mathcal{E}$  the error term.  $\alpha_0$  to  $\alpha_6$  are the parameters to estimate.

## 2.2. The Variables

### 2.2.1. Annual Conflict-Based Domestic Incidents as Proxy for Internal Conflict

We have processed our proxy for internal conflict from the Global Terrorism Database (GTD, 2018). The conflict-based incidents in the GTD codebook are defined as “the threatened or actual use of illegal force and violence by a non-state actor to attain a political, economic, religious, or social goal through fear, coercion, or intimidation”. The time period for the annual data is from 2004 to 2017).

### 2.2.2. GDP per Capita as Proxy for Income and Wealth

The empirical evidence for the impact of income and wealth on internal conflict yields mixed results. Some of the literature finds poverty and low income a cause of violence. Humphreys (2003) indicates that low resources increase the likelihood of civil wars. Collier and Hoeffler (2004) show that low incomes increase domestic conflict. By contrast, Caruso and Schneider (2011) find a positive relationship between increased income and the number of people killed in conflict-based incidents. Freytag et al (2011) confirm that there is a positive correlation between increasing GDP per capita and increased violence. Piazza (2008) however does not find a significant association between the two variables. In this study, we hypothesize that economically disadvantaged people in fragile states develop grievances against their government, and that poor economic conditions make violence more likely because direct costs (including rebels’ recruitment) and opportunity costs are low GDP per capita is our measure of income and wealth. The data comes from WDI (2017). The study uses the logarithm of the variable in real terms. In line with one part of the literature, we expect a negative influence of this variable on our variable of conflict.

### 2.2.3. Effective Judiciary as a Proxy for Deterrence

Countries with fragile institutions are vulnerable to violence (Basuchoudhary and Shughart 2010). It is easier for extremists’ groups to operate in states where institutions are weak (Newman, 2007, Piazza, 2008). If the justice system is effective and the penalties are perceived as fair, the threat of punishment can change the behavior of individuals. Freytag et al (2011) state that the possibility of punishment is a cost to opponents. Dezhbakhsh et al (2003) confirm that the likelihood of punishment leads to a decrease in crime in a country. We use the "Time for Enforcing Contracts" variable from the "Doing Business" database as an indirect indicator of the ineffectiveness of the judiciary. If the judiciary punishes in a timely manner, the population will be reluctant to use violence. In this study, we expect a positive impact of the judicial ineffectiveness variable on conflict.

### 2.2.4. Education and Human Capital as Proxy for Human Development

Human development might be seen as a way to lessen violence by reducing people's grievances (Kurrild-Kitgaard et al, 2006). Educated people may also use critical thinking to reject extremism (Ghosh et al, 2017). Educated people have as well more opportunities to improve their economic and social situation (Berrebi, 2007), thus increasing the opportunity cost of conflict (Freytag et al, 2011). At the empirical level, Hamilton and Hamilton (1983) note that illiteracy is positively correlated with armed violence. Collier and Hoeffler (2004) highlight the negative impact of education on conflict. Brockhoff et al (2015) however, show that in countries where social, economic, political, and demographic conditions are unfavorable, education can exacerbate discontent if access to education does not translate into the expected better life. In addition, extremists’ groups may have an interest in recruiting educated people, as this can

increase the chances of success of their activities, as well as contribute to a better image for their propaganda in the media (Krueger and Maleckova, 2003). We use two different indexes for human development as explanatory variable for conflict: (i) The average number of years of schooling of population aged 25 or older from the United Nations Development Program (UNDP)<sup>5</sup>; (ii) The Human Capital index of the Penn World Table (PWT 9.1, Feenstra et al, 2015)<sup>6</sup>. In accordance with part of the literature, we assume that education provides people with more economic opportunities that increase the opportunity cost of using illegal force, as well as a level of knowledge that encourages them not to choose violence. A negative sign in the equation is therefore expected.

### 2.2.5. *Trade Openness as Proxy for Economic Reforms*

The influence of economic reforms on violence is another dimension studied in the literature. Trade reforms can be a factor of growth and modernization of the economy. New opportunities created by trade can reduce the discontent of the population and increase the opportunity cost of violence, thus reducing the risk of civil unrest. Blomberg and Hess (2008) and Kurrild-Klitgaard et al (2006) find an inverse relationship between trade openness and the use of illegal force which would confirm that reforms can help reduce violence. Another part of the literature, however, emphasizes the destabilizing effect of economic reforms. Caruso and Schneider (2011) state that reforms can reduce the wealth of some stakeholders. In this case, reforms can lead to political and social unrest fueled by groups of people who lose or fear losing because of change (Gaibullov and Sandler, 2019). In this study, we assume that trade openness reduces violence and promotes a country's development. A negative relationship with conflict is thus expected. We use the ratio of exports plus imports to GDP (in real terms), as proxy for trade reform and globalization. The data are from National and International sources.

### 2.2.6. *Democratic Accountability as Proxy for Democracy*

The impact of the political regime on violence and civil unrest in a country is another dimension whose empirical evidence is contradictory. Some of the literature emphasizes that democratic regimes allow people to express their demands and be heard, thereby reducing the grievances they may have towards the government. This is the case of Li (2005) who highlights a positive relationship between democracy and the absence of violence. However, other authors point out that it is easier and cheaper for extremists to engage in violent activities when they enjoy more civil liberties and political rights. Li and Schaub (2004) and Rizvi and Véganzonès-Varoudakis (2019) note an increase of violence in fragile countries during democratic periods. Eubank and Winberg (1998) find that terrorism occurs more often in democracies than in more authoritarian regimes. We use the Democratic Accountability variable, derived from the International Country Risk Guide (ICRG), as an indicator of the type of regime, to explain internal conflicts in fragile states (Howell, 2011). A high value indicates more democracy and vice-versa. In line with one part of the literature, we expect a positive relationship of the variable with the conflict variable for our different samples of fragile countries.

### 2.2.7. *The role of Population*

In addition to the above variables, we study the impact of the size of a country's population on the development of conflicts in that country. Krueger and Maleckova (2003), Freytag et al (2011) and Piazza (2008) point out that more populous countries tend to face more violence. Gaibullov and Sandler (2019) and Taydas et al (2011) argue that it is difficult for governments to manage, serve, and respond to the demands of all in the case of large populations, due in part

<sup>5</sup> <http://hdr.undp.org/en/content/human-development-index-hdi>

<sup>6</sup> [www.gdc.net/pwt](http://www.gdc.net/pwt)

to a great diversity. According to the literature, we expect a positive relationship between population and conflict in our samples of fragile countries. We use the population variable from WDI (2017) in logarithm.

### 2.3. Estimation of the Model: Methodological Aspects

This study focuses on fragile countries selected from the Fund for Peace (FFP) database that publishes annually a Fragile States Index (FSI)<sup>7</sup>. We selected 58 countries for which the index was above 70 for the analysis, which corresponds to a high degree of fragility. We analyze the development of conflict activities from 2004 to 2017 for 4 different groups: (i) Total sample of fragile countries, (ii) Islamic fragile states, (iii) Fragile countries with more than one important religion<sup>8</sup>, (iv) States affected by major conflicts<sup>9</sup>.

Since we have the annual number of conflict-based domestic incidents from the Global Terrorism Database (GTD) as proxy for violence, this implies that our dependent variable is a non-negative integer (count data)<sup>10</sup>. We use Fixed Effect Poisson Regressions (FEPR) with robust standard errors to address the issues related to count data. Poisson estimators are particularly suitable in the case of rare events, which correspond well to our situation (see Krieger and Meierrieks, 2011, for a synthesis).

## 3. THE RESULTS OF THE ESTIMATIONS

Table 1 presents the results for the total sample of countries, Table 2 for the Islamic States, Table 3 for the countries with more than one main religion, and Table 4 for the countries affected by major conflicts. For almost all of our specifications and our groups of countries, income, ineffectiveness of the justice system, and size of the population are correlated with the development of domestic conflict in our fragile states. These results corroborate the findings of Humphreys (2003), Collier and Hoeffler (2004) and Lai (2007) who show that low incomes are positively associated with violence. Improving incomes therefore seems to be a policy variable that governments should be able to use to reduce violence in fragile states. These results also indicate that another way to reduce conflict in fragile countries could be to improve institutions, especially the justice system. This seems consistent with the findings of Dezhbakhsh et al (2003) who confirm the dissuasive effect of the threat of sanctions. With regard to the population size variable, our results are in line with those of Gaibulloev and Sandler (2019) and Taydas et al (2011) who show that fragile countries with big populations are more exposed to violence. Our results also show a positive relationship between the education and democracy variables and that of conflict. Our findings indicate that, in fragile countries, education may not translate into an opportunity to improve living conditions or as a means of strengthening critical thinking against terrorism, as in Berrebi (2007) and Brockhoff et al (2015). This conclusion can be extrapolated to democracy, which can give more voices to discontented groups, thereby increasing violence, as in Eubank and Winberg (1998) and Li and Schaub (2004). Our results would mean that education and political rights may not have the desired effects in fragile states which would likely first have to improve the social, economic and institutional conditions of their population before they can benefit from political reforms and education. This may also be the case for economic reforms, as our trade openness variable is not correlated with violence in most of our country samples, as in Gaibulloev and Sandler (2019). A more detailed analysis shows interesting differences between groups of countries.

<sup>7</sup> See <https://fragilestatesindex.org/data/>

<sup>8</sup> Countries where more than 10% of people belong to a different religious group

<sup>9</sup> Countries having had at least 5 conflict-related incidents per year for at least half of the period studied

<sup>10</sup> For more details on count data regression see Cameron and Trivedi (2013)

The correlation of the conflict variable with that of income, while relatively stable in most of our samples, seems stronger in countries with more than one major religion. This is an interesting finding which could indicate that public policies aimed at improving people's incomes and living conditions could be more effective in these particularly poor and fragile countries. The results are fairly similar for the population size variable, whose correlation with the conflict variable is stronger for this group as well. This may be due to the fact that several highly populated countries belong to this group, illustrating the difficulties faced by governments in meeting the needs of a large and diverse population. The results are more diverse for the judicial system.

The improvement in the efficiency of justice is more correlated with the decrease in violence in Muslim states and countries with more than one main religion, than in the other groups. This is interesting because some countries in these groups may be less involved in long-term and high-intensity violence than those in the group of countries affected by major conflicts. Improving the judicial system and, more generally, the institutions could therefore prevent the escalation of violence in these fragile countries. The two education variables, the human capital index (published by the PWT), and the average number of years of schooling of the population aged 25 and older (UNDP) are almost always significant for all groups. This may be related to the fact that religion and ethnic differences are an important factor in conflicts in most of our fragile countries. In this case, education could serve the cause of terrorists by allowing certain segments of the population to be more involved in violence.

For the four groups of countries, the differences in estimated coefficient are not very significant, except for countries with more than one main religion where the impact seems weaker. The same conclusions can be drawn for democracy, with a stronger impact in Muslim countries and no impact for countries with more than one main religion. This may be due to the fact that some countries in the latter group are more democratic than most countries in the group of Muslim States. In most Muslim countries, experiences of democracy have most often been followed by an increase in violence. Finally, as mentioned above, trade liberalization does not seem to be correlated with an increase or reduction in violence in our various samples of countries. This observation therefore does not make it possible to decide between the hypothesis of a negative impact of economic reforms on violence, if these lead to an improvement in the prospects and incomes of the population (as in Blomberg and Hess (2008) and Kurrild-Klitgaard and al (2006)), or positive, if they are perceived as a threat of income loss or worsening of inequalities (as in Freytag et al, 2011).

*Table following on the next page*

*Table 1: Fixed Effect Poisson Regression for Total Fragile Countries*

<b>Variables</b>	<b>Specif. 1</b>	<b>Specif 2</b>	<b>Specif 3</b>
<b>lpop</b>	4.318*** (0.70)	4.491*** (0.86)	2.944*** (0.79)
<b>lgdpc</b>	-1.164*** (0.32)	-1.063*** (0.37)	-0.479** (0.24)
<b>Edum</b>	0.758*** (0.17)	0.681*** (0.18)	
<b>H</b>			4.957*** (0.98)
<b>Contracts</b>	1.353* (0.77)	1.360* (0.79)	1.11 (0.88)
<b>Open</b>	(0.32) (1.00)	(0.46) (1.03)	0.09 (0.99)
<b>Demo</b>	0.113** (0.06)	0.087* (0.05)	0.262*** (0.06)
<b>Observations</b>	812	714	714
<b>Nber of counnum</b>	58.00	51.00	51.00

*Note:* Dependent variable is annual number of terrorist-based domestic incidents, robust standard errors are given in parenthesis, significance level: \*\*\*, \*\*, \* is less than 1%, 5% and 10% respectively.

*Table 2: Fixed Effect Poisson Regression for Muslim Fragile Countries*

<b>Variables</b>	<b>Specif 1</b>	<b>Specif 2</b>	<b>Specif 3</b>
<b>lpop</b>	4.431*** (0.92)	4.652*** (1.08)	2.734*** (0.88)
<b>lgdpc</b>	-1.251*** (0.27)	-1.108*** (0.30)	-0.556** (0.26)
<b>Edum</b>	0.591 (0.40)	0.452 (0.42)	
<b>H</b>			4.629*** (1.63)
<b>Contracts</b>	2.425*** (0.81)	2.518*** (0.92)	2.094*** (0.67)
<b>Open</b>	-0.082 (1.13)	-0.384 (1.22)	0.205 (1.20)
<b>Demo</b>	0.158** (0.06)	0.135** (0.06)	0.286*** (0.06)
<b>Observations</b>	350	294	294
<b>Nber of counnum</b>	25	21	21

*Note:* Dependent variable is annual number of terrorist-based domestic incidents, robust standard errors are given in parenthesis, significance level: \*\*\*, \*\*, \* is less than 1%, 5% and 10% respectively.



*Table 3: Fixed Effect Poisson Regression for Fragile Countries Affected by Major Conflicts*

<b>Variables</b>	<b>Specif 1</b>	<b>Specif 2</b>	<b>Specif 3</b>
<b>lpop</b>	4.195*** (0.66)	4.367*** (0.82)	2.682*** (0.68)
<b>lgdpc</b>	-1.180*** (0.31)	-1.078*** (0.37)	-0.471* (0.25)
<b>Edum</b>	0.750*** (0.18)	0.671*** (0.18)	
<b>H</b>			4.949*** (0.99)
<b>Contracts</b>	1.511* (0.80)	1.498* (0.84)	1.28 (0.92)
<b>Open</b>	-0.441 (1.06)	-0.593 (1.10)	-0.104 (1.03)
<b>Demo</b>	0.122** (0.06)	0.095* (0.05)	0.280*** (0.06)
<b>Observations</b>	308	280	280
<b>Nber of counnum</b>	22	20	20

*Note:* Dependent variable is annual number of terrorist-based domestic incidents, robust standard errors are given in parenthesis, significance level: \*\*\*, \*\*, \* is less than 1%, 5% and 10% respectively.

*Table 4: Fixed Effect Poisson Regression for Fragile Countries with more than One Main Religion*

<b>Variables</b>	<b>Specif 1</b>	<b>Specif 2</b>	<b>Specif 3</b>
<b>lpop</b>	8.312*** (2.87)	11.147*** (1.78)	9.497*** (1.61)
<b>lgdpc</b>	-1.531*** (0.08)	-1.571*** (0.09)	-1.090*** (0.09)
<b>Edum</b>	0.725*** (0.26)	0.499** (0.21)	
<b>H</b>			3.794*** (0.94)
<b>Contracts</b>	2.976 (2.57)	4.961** (2.20)	3.977* (2.19)
<b>Open</b>	1.867 (1.63)	1.834 (1.72)	1.907 (1.41)
<b>Demo</b>	-0.155 (0.45)	-0.409 (0.45)	-0.412 (0.40)
<b>Observations</b>	238	224	224
<b>Nber of counnum</b>	17	16	16

*Note:* Dependent variable is annual number of terrorist-based domestic incidents, robust standard errors are given in parenthesis, significance level: \*\*\*, \*\*, \* is less than 1%, 5% and 10% respectively.

#### 4. CONCLUSION

In this article, we use Fixed Effect Poisson Regression (FEPR) with robust standard errors to study the social, economic, and institutional determinants of conflict in 58 fragile states divided into 4 groups. We show that poverty and weak institutions (weak judicial system in particular) are two important dimensions positively correlated with violence in our samples of fragile countries. On the other hand, education and democracy do not seem to help reduce violence in fragile states, our two proxy variables showing a positive relationship with conflict. Our results imply that education and political rights could not have the desired effects in fragile states, which would probably first have to improve the social, economic, and institutional conditions of their population before they can benefit from political reforms and education of their population. This is also the case for economic reforms, since our indicator of trade openness is not correlated with violence in all groups. Although this general pattern works fairly well for most of our country groups, some groups experience somewhat different situations. This is the case for countries with more than one major religion, where improving incomes and improving the efficiency of the justice system seem to be more effective in reducing violence than in the other groups. This is an interesting finding which governments could take into account to reduce the escalation of violence in these particularly fragile countries. Muslim states also appear to be particularly sensitive to the deterrent effect of sanctions which, for governments, could be an effective means of combating violence. Muslim countries, on the other hand, seem to experience a comparative higher increase in violence during democratic times. These findings could mean that in countries particularly prone to the use of illegal force, political rights should probably not be reintroduced until the restoration of order and effective institutions. Conflicts in fragile states cause great suffering for people, as well as delays in development. This study highlights some tools that governments could probably use to try to limit violence in their country. Improving people's standard of living and restoring strong and reliable institutions are measures that could bear fruit in most fragile countries. On the other hand, the question of the role of education, political rights, and economic reforms is more complex to deal with. If in the short term these instruments do not seem to contribute to the reduction of conflicts and violence in the countries concerned, it may be thought that the priority of fragile states is to provide their populations with a safer economic, political, and institutional environment before these populations can benefit from more advanced reforms.

#### LITERATURE:

1. Basuchoudhary, A. and Shughart, W.F. (2010). On Ethnic Conflict and Origins of Transnational Terrorism. *Defense and Peace Economics*, 21(1):65-87
2. Berrebi, C. (2007). Evidence About the Link Between Education, Poverty and Terrorism Among Palestinians. *Peace Economics, Peace Science and Public Policy*, 13(1).
3. Blomberg, S.B. and Hess, G.D. (2008), "From (no) Butter to Guns? Understanding the Economic Role in Transnational Terrorism", in P. Keefer and Loayza, N. (eds), *Terrorism, Economic Development, and Political Openness*. United Kingdom: Cambridge University Press.
4. Brockhoff, S., Krieger, T. and Meierrieks, D. (2015). Great Expectations and Hard Times: The (Nontrivial) Impact of Education on Domestic Terrorism. *Journal of Conflict Resolution*, 59(7), 1186-1215.
5. Cameron A.C. and Trivedi, P.K. (2013), *Regression Analysis of Count Data*, Econometric Society Monograph No.53, Cambridge University Press (2nd edition)
6. Caruso, R. and Schneider, F. (2011). The Socio-Economic Determinants of Terrorism and Political Violence in Western Europe (1994–2007). *European Journal of Political Economy*, 27, S37-S49.
7. Coggins, B. L. (2015). Does State Failure Cause Terrorism? An Empirical Analysis (1999–2008). *Journal of Conflict Resolution*, 59(3), 455-483.

8. Collier, P. (2007). *The Bottom Billion: Why the Poorest Countries are Failing and What Can be Done About it*. New York: Oxford University Press.
9. Collier, P. and Hoeffler, A. (2004). Greed and Grievance in Civil War. *Oxford Economic Papers*, 56(4), 563-595.
10. Dezhbakhsh, H., Rubin, P. H. and Shepherd, J. M. (2003). Does Capital Punishment Have a Deterrent Effect? New Evidence from Post Moratorium Panel Data. *American Law and Economics Review*, 5(2), 344-376.
11. Eubank, L.B. and Winberg, W.L. (1998). Terrorism and Democracy: What Recent Events Disclose? *Terrorism and Political Violence*, 10 (1): 108-118.
12. Feenstra, R.C., Robert, I. and Marcel, P.T. (2015), "The Next Generation of the Penn World Table" *American Economic Review*, 105(10), 3150-3182, available for download at [www.ggdcd.net/pwt](http://www.ggdcd.net/pwt)
13. Freytag, A., Krüger, J. J., Meierrieks, D. and Schneider, F. (2011). The Origins of Terrorism: Cross-Country Estimates of Socio-Economic Determinants of Terrorism. *European Journal of Political Economy*, 27, S5-S16.
14. Gaibulloev, K. and Sandler, T. (2019). Terrorism and Affinity of Nations. *Public Choice*, 178(3-4), 329-347.
15. Gur, T. (1970). *Why Men Rebel*. Princeton: Princeton University Press
16. Hamilton L.C. and Hamilton, J.D. (1983). Dynamics of Terrorism. *International Studies Quarterly* 27(1): 39-54.
17. Howell, L.D. (2011). *International Country Risk Guide Methodology*. East Syracuse, NY: PRS Group
18. Humphreys, M. (2003). *Economics and Violent Conflict*. Cambridge, MA.
19. Huntington, S.P. (1996). Democracy for the Long Haul. *Journal of Democracy* 7(2): 3-13
20. Krieger, T., and Meierrieks, D. (2011). What causes terrorism? *Public Choice*, 147(1-2), 3-27
21. Krueger, A. B. and Malečková, J. (2003). Education, Poverty and Terrorism: Is There a Causal Connection? *Journal of Economic perspectives*, 17(4), 119-144.
22. Kurrild-Klitgaard, P., Justesen, M. K. and Klemmensen, R. (2006). The Political Economy of Freedom, Democracy and Transnational Terrorism. *Public Choice*, 128(1-2), 289-315.
23. Lai, B. (2007). "Draining the Swamp": An Empirical Examination of the Production of International Terrorism, 1968—1998. *Conflict Management and Peace Science*, 24(4), 297-310.
24. Li, Q. and Schaub, D. (2004). Economic Globalization and Transnational Terrorism: A Pooled Time-Series Analysis. *Journal of Conflict Resolution*, 48(2), 230-258.
25. Newman, E. (2007). Weak States, State Failure, and Terrorism. *Terrorism and Political Violence*, 19(4), 463-488.
26. Olson, M. (1963). Rapid Growth as a Destabilizing Force. *The Journal of Economic History*, 23(4), 529-552.
27. Piazza, J. A. (2008). Incubators of Terror: Do Failed and Failing States Promote Transnational Terrorism? *International Studies Quarterly*, 52(3), 469-488.
28. Rizvi, S. M. and Véganzonès-Varoudakis, M. A. (2019). Conflict, Growth and Human Development. An Empirical Analysis of Pakistan.
29. Stewart, F. (2005). Horizontal Inequalities: A Neglected Dimension of Development. In *Wider perspectives on global development* (pp. 101-135). Palgrave Macmillan, London.
30. Taydas, Z., Enia, J. and James, P. (2011). Why Do Civil Wars Occur? Another Look at the Theoretical Dichotomy of Opportunity Versus Grievance. *Review of International Studies*, 37(5), 2627-2650.
31. World Bank (2018). *Pathways for Peace: Inclusive Approaches to Preventing Violent Conflict*. World Bank: Washington DC

# AN APPLICATION OF GENERATING FUNCTION AS A PROCESS ANALYSIS TOOL

**Adela Poliaková**

*University of Žilina, Faculty of Operation and Economics of Transport and Communications,  
Department of Economics, Univerzitná 8215/1, 010 26 Žilina, Slovakia  
adela.poliakova@fpedas.uniza.sk*

## ABSTRACT

*Markov chains are considered to be the simplest type of Markov processes. By examining the processes, we find out what states the process can get into. Sometimes it is a large number of states, if we consider a system that can achieve evaluations, such as marking students at school, or it can be a process that will have only two values: yes - no, functional - non-functional, on - off, etc. The article presents some basic findings that can be used in the analysis of Markov chains. If we realize that a system can have several states, where there are a number of transitions with individual probabilities, it is obvious that monitoring similar systems is possible only with a suitable mathematical application. It is therefore advantageous to use the form of a matrix to express all probabilities. The article deals with the possibility of using a matrix in the form of a generating function. Their use is advantageous especially in the management of the company. If the reliability of the systems is known, the application of the generating function allows the prediction of the process for a sufficiently long period. The paper simulates an example where, based on the observed probabilities of state changes, we create a matrix of conditional transition probabilities. The simulation is based on both hypothetical situations: the vehicle is operational and the vehicle is not operational. The application of the generating function based on Markov chains is carried out on a simple example of determining the operability of an older car after the  $x$ -th period.*

**Keywords:** *generating function, Markov chain, Markov process*

## 1. INTRODUCTION

According to Unčovský (1980), Markov chains are considered to be the simplest type of Markov processes. By examining the processes, we find out what states the process can get into. Sometimes it is a large number of states, if we consider a system that can acquire evaluations, such as marking students at school, or it can be a process that will have only two values: yes - no, functional - non-functional, on - off, etc. A process that can acquire some states at random is called stochastic. We usually refer to the stochastic process as:  $\{X(t), t \in I\}$ , where  $t$  is a system of random variables and  $I$  is the interval resp. set of discrete numbers. The Markov process is a special type of stochastic process, where the result of one random variable  $X(t)$  depends on the result of the previous value  $X(s)$  and affects the next state, i.e. the value  $X(u)$ , where  $t > s > u$ . Thus the results of states in which the process is located, they create a consecutive system, which we are used to refer to as the Markov chain. The definition of Markov process according to Pinsky and Carlin (2011) is similar: **A Markov process  $\{X_t\}$  is a stochastic process with the property that, given the value of  $X(t)$ , the values of  $X(s)$  for  $s > t$  are not influenced by the values of  $X(u)$  for  $u < t$ . In words, the probability of any particular future behavior of the process, when its current state is known exactly, is not altered by additional knowledge concerning its past behavior. The states into which the individual processes enter in this case are characterized by their own and temporal discretion. In practice, this means that each result of such a process is unique and the process results in this result only under given specific conditions. Thus, the system under investigation may end up in one of a finite number of states or in one of an infinite but countable number of states. According to Unčovský (1980) and Oliver (2013), this fact can be recorded:**

$$S_i (i = 1, 2, \dots, m) \quad (1)$$

### 1.1. System transitions

The transition from one state to another can be realized in one step or even in several steps. (Unčovský, 1980) (Neuschl, 1988) (Berezny, 2015) This fact is usually written as follows:

$$S_1^{(k)}, S_2^{(k)}, S_3^{(k)}, \dots, S_m^{(k)} \quad (2)$$

where:

$k$  ..... means that the given state is realized in the  $k$ -th step. The state of the system in the initial step is thus denoted  $S_j^{(0)}$  and the probability that the system is in the  $j$ -th state is different and is denoted:

$$P_j^{(k)} = P(S_j^{(k)}) \quad (3)$$

Since the transition from one state to another can take place in several steps, the probability with which the state enters another state also varies. The probability of this transition (sometimes referred to in the literature as the conditional probability) indicates that the system is in the state  $S_j$  in the  $k$ -th step if in the  $(k-1)$ -th step it was in the state  $S_{j-1}$  resp. in the state of  $S_i$ . We write the conditional probability:

$$p_{ij}^{(k)} = P(S_j^{(k)} | S_{j-1}^{(k-1)}) = P(S_j^{(k)} | S_i^{(k-1)}) \quad (4)$$

Unčovský (1980) states that in addition to the mentioned elements, the Markov chain is also characterized by the well-known Markov property. The sequence of states  $S_j$  of the system is a Markov chain if the equation holds for any  $i, j, k = 1, 2, \dots$ :

$$p_{ij}^{(k)} = P(S_j^{(k)} | S_i^{(k-1)}) = P(S_j^{(k)} | S_i^{(k-1)}, S_{ik-2}^{(k-2)}, \dots, S_{il}^{(1)} | S_{i0}^{(0)}) \quad (5)$$

for each:

$$S_{ik-2}^{(k-2)}, \dots, S_{il}^{(1)}, S_{i0}^{(0)} \quad (6)$$

It follows from the above definition that in the case of a Markov chain, the probability of transition from the  $S_i$  state to the  $S_j$  state in each step does not depend on where and when the system got to the  $S_i$  state.

### 1.2. Transition probability matrix

When analyzing Markov chains, we often work with transition probability matrices. A Markov chain whose transition probabilities  $P_{ij}^{(t)}$  do not depend on  $t$  is called a homogeneous Markov chain. Thus, for each homogeneous Markov chain, the transition probabilities  $P_{ij} = P_{ij}^{(t)}$  correspond for each  $i, j \geq 1$ , which we can compile into a transition probability matrix  $P$ .

If we realize that a system can have several states, where there are a number of transitions with individual probabilities, it is obvious that monitoring similar systems is possible only with a suitable mathematical application. It is therefore advantageous to use the form of a matrix to express all probabilities. The Markov chain transition probability matrix is called  $P$ . (Neuschl, 1988) (Pinsky, Karlin, 2011)

The matrix  $P$  is a stochastic matrix, the individual elements of which are the probabilities of the transition  $p_{ij}$  and has the form:

$$P = \begin{pmatrix} p_{11} & p_{12} & \dots & p_{1m} \\ p_{21} & p_{22} & \dots & p_{2m} \\ \dots & \dots & \dots & \dots \\ p_{m1} & p_{m2} & \dots & p_{mm} \end{pmatrix} \quad (7)$$

Since it is a stochastic matrix, it is obvious that it does not contain negative numbers, i.e.  $0 \leq p_{ij} \leq 1$  and  $\sum_{j=1}^m p_{ij} = 1$ .

## 2. USE OF GENERATING FUNCTIONS

According to Valaskova, Kliestik, Misankova (2018) the financial risk may be defined as a potential financial loss of a subject, i.e. an existing realized or non-realized financial loss, but also a future loss given by the financial or commodity tools. Šalaga, Bartošová, Kicová (2015) emphasize that in determining the possible loss, it is necessary to draw data from corporate accounting. We come across a similar statement in Rybicka, Rybicki (2018), who add that "Measurement of events in the accounting system is based on information obtained from source documents on the basis of which accounting entries are made." However, the above presupposes the harmonization of requirements and standards of accounting, which they address in their contribution Hoang and Joseph (2019). Markov chains with transition probability matrices can be a useful tool in determining potential economic loss. The cost prediction is very important (Poliak et al., 2017, 2019) for economic loss determination for future periods. According to Kapusta and Kalasova (2015), the number of accidents is a good safety indicator. So we simulate an example where we monitor the failure of a vehicle.

The use of creating functions consists in determining the appropriate image transformation to a given original (pattern), while performing the appropriate operations in the scope of the transformed function and performing a reverse transformation in order to obtain a solution in the original scope. It can be shown that there is a clear representation between the original function and its image, therefore to facilitate calculations in practice, dictionaries of transformations are used for generating functions, i. j. tables of typical functions and their transformations. (Berezny, 2015)

We define a generating function to a function  $f(n)$  for  $n > 0$  as follows:

$$F(z) = f(0) + f(1) \cdot z + f(2) \cdot z^2 + f(3) \cdot z^3 + \dots = \sum_{n=0}^{\infty} f(n) \cdot z^n \quad (8)$$

where  $|z| < 1$ . The function  $f(n)$  is called the original (transformed) function and the function  $F(z)$  is called the generating function ( $z$ -transformation of the original function).

Here are some basic findings that we will use in the analysis of Markov chains. Berezny (2015) claims that the original function is given by the formula  $f(n) = 1$ , then the generating function is a function  $F(z) = 1/1 - z$ . Berezny (2015) shows that for the function  $f(n) = n$  we get the transformation:

$$F(z) = \sum_{n=0}^{\infty} n \cdot z^n = \sum_{n=0}^{\infty} n \cdot z^{n-1} \cdot z = \sum_{n=0}^{\infty} z \cdot \frac{dz^n}{dz} = z \cdot \frac{d}{dz} \left( \sum_{n=0}^{\infty} z^n \right) = \frac{z}{(1-z)^2}. \quad (9)$$

For the original function  $f(n) = a^n$ , where  $|a| \leq 1$ , is the generating function  $F(z)$  in the form:

$$F(z) = 1 + a \cdot z + a^2 \cdot z^2 + a^3 \cdot z^3 + \dots = \sum_{n=0}^{\infty} a^n \cdot z^n = \frac{1}{(1-a \cdot z)}. \quad (10)$$

The individual patterns and figures are given in the tables of  $z$ -transformations, some of which are given in Table 1:

f(n)	F(z)
1	$\frac{1}{1-z}$
n	$\frac{z}{(1-z)^2}$
a <sup>n</sup>	$\frac{1}{(1-az)}$
n · a <sup>n</sup>	$\frac{a \cdot z}{(1-a \cdot z)^2}$

Table 1: Table of z-transformations  
(Source: Berezny,2015)

In the analysis of Markov chains, vectors or matrices are often transformed. If we apply the above z-transformations to each element of the vector resp. matrix, so we say that we perform a z-transformation of the whole vector, respectively. whole matrix. We get the creating function of the vector resp. matrix. According to the relation (8) the generating function of a vector  $\vec{u}(n)$  can be written in the form:

$$F(z) = \vec{u}(0) + \vec{u}(1) \cdot z + \vec{u}(2) \cdot z^2 + \vec{u}(3) \cdot z^3 + \dots = \sum_{n=0}^{\infty} \vec{u}(n) \cdot z^n \quad (11)$$

In a similar way (according to the relation (8)) we can write a generating function for the matrix U(n), which has the form:

$$F(z) = U(0) + U(1) \cdot z + U(2) \cdot z^2 + U(3) \cdot z^3 + \dots = \sum_{n=0}^{\infty} U(n) \cdot z^n \quad (12)$$

If U(n) is denoted by A<sup>n</sup>, where A is a square matrix, based on the application of equation (10) the following equation is applied:

$$\sum_{n=0}^{\infty} A^n \cdot z^n = I + A \cdot z + A^2 \cdot z^2 + A^3 \cdot z^3 + \dots = (I - A \cdot z)^{-1} \quad (13)$$

where I is the inverse matrix and (I - A · z)<sup>-1</sup> is expressed as the sum of an infinite geometric series. If the matrix (I - A · z) is regular, then there is an inverse matrix (I - A · z)<sup>-1</sup> to the matrix (I - A · z). For the function f(n) = n · A<sup>n</sup> the transformation holds: F(z) = z · (I - A · z)<sup>-1</sup> · A · (I - A · z)<sup>-1</sup>. Let's look at the vector of absolute probabilities. We can create a generating function F(z) in the form (11):

$$F(z) = \sum_{n=0}^{\infty} \vec{p}(n) \cdot z^n \quad (14)$$

We know that for the vector of absolute probabilities the relation holds:

$$\vec{p}(n + 1) = \vec{p}(n) \cdot P \quad (15)$$

where P is the transition probability matrix. Then we can write the generating function F(z) in the form:

$$F(z) = \sum_{n=0}^{\infty} \vec{p}(n + 1) \cdot z^n = \sum_{n=0}^{\infty} \vec{p}(n) \cdot P \cdot z^n \quad (16)$$

We can modify the left side of this equation (16) and get the equality:

$$F(z) = \sum_{n=0}^{\infty} \vec{p}(n + 1) \cdot z^n = \frac{1}{z} \cdot \left[ \sum_{n=1=0}^{\infty} \vec{p}(n + 1) \cdot z^{n+1} - \vec{p}(0) \right] \quad (17)$$

The expression  $\sum_{n+1=0}^{\infty} \vec{p}(n+1) \cdot z^{n+1}$  is also a generating function of  $F(z)$ . The following applies:

$$\frac{1}{z} \cdot (F(z) - \vec{p}(0)) = F(z) \cdot P \tag{18}$$

From this equation we express  $F(z)$  and we get:

$$F(z) = \vec{p}(0) \cdot (I - z \cdot P)^{-1} \tag{19}$$

where  $I$  is the unit matrix and  $(I - z \cdot P)^{-1}$  is the inverse of the matrix  $(I - z \cdot P)^{-1}$ . From the above relation it can be seen that by using the generating functions we avoid the calculation of the  $n$ -th powers of the transition probability matrix  $P$ .

### 3. PRACTICAL APPLICATION OF GENERATING FUNCTIONS FROM ECONOMICS POINT-OF-VIEW

Consider the operation of an older passenger car, which can be in two states: state  $s_1$  - operational, state  $s_2$  - under repair. Experience with this type of car (or data from managerial accounting) allows the following statements to be made. If this car is in working order for one period of time, then in the next period it was still operational for 50% or needed to be repaired for 50%. However, if it was under repair in the period under review, then in the following period it remained in repair in 30% or in 70% of cases it was operational again. Using the transition probability matrix, we determine the probabilities of the states of this car for the next 5 time periods. In the above simple example, we can schematically record the possible development as follows (Figure 1):

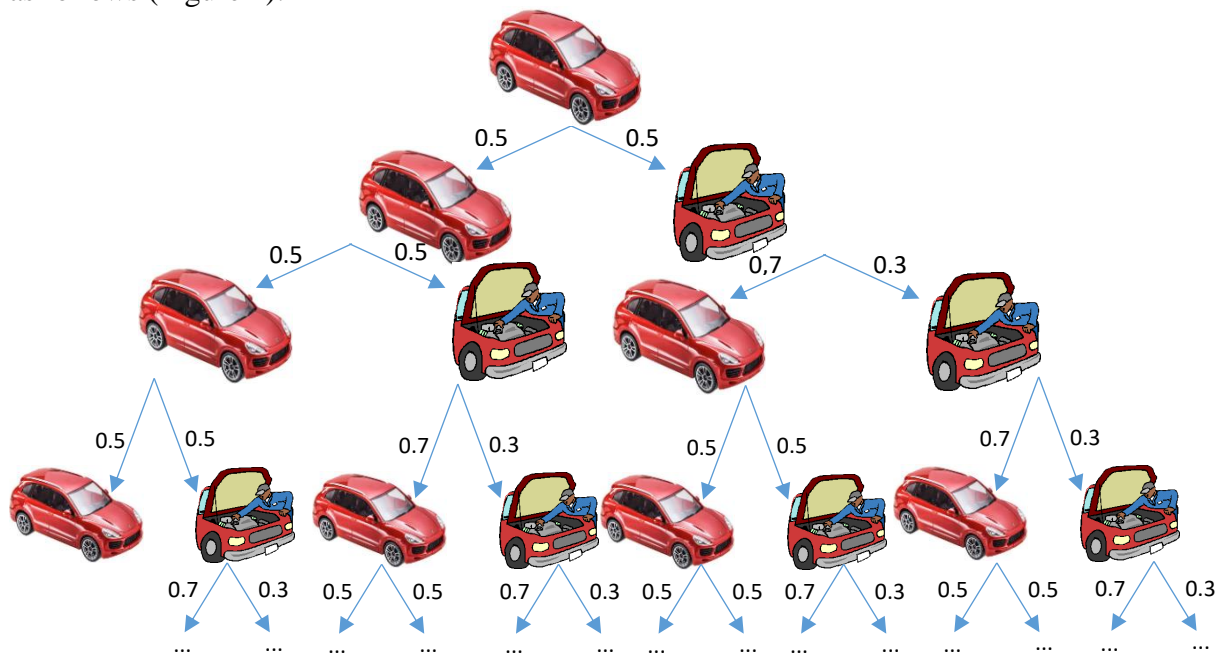

Figure 1: Possible development after three and more periods  
(Source: Own processing)

Our considered system is thus formed by two states  $s_1$  and  $s_2$ . If it is in state  $s_1$ , the car can drive, if it is in state  $s_2$ , it needs repair. How to predict a car safety after  $x$ -periods? Based on the stated probabilities of state changes, we can create a matrix of conditional transition probabilities as follows:



$$P = \begin{pmatrix} 0,5 & 0,5 \\ 0,7 & 0,3 \end{pmatrix} \quad (20)$$

We start from the state in which the car is at the beginning of the monitoring, i.e. in the operational state - in the state  $s_1$ . The initial vector of absolute probabilities has the form:

$$\vec{p}(0) = (1; 0)$$

Then the vector of absolute probabilities after the first time period after application of (15) will be:

$$\vec{p}(1) = \vec{p}(0) \cdot P = (1; 0) \cdot \begin{pmatrix} 0,5 & 0,5 \\ 0,7 & 0,3 \end{pmatrix} = (0,5; 0,5)$$

Thus, operation and repair of a car after the end of the first time period are equally likely. Let us determine the vector of absolute probabilities for the second period (we use the equation (15) again):

$$\vec{p}(2) = \vec{p}(1) \cdot P = (0,5; 0,5) \cdot \begin{pmatrix} 0,5 & 0,5 \\ 0,7 & 0,3 \end{pmatrix} = (0,6; 0,4)$$

In our case, therefore, after the second period, the vehicle will remain in working order with a probability of 60% and with a probability of 40% will need to be repaired. This is how we calculated the situation after the second time period. Similarly for the third time period:

$$\vec{p}(3) = \vec{p}(2) \cdot P = (0,6; 0,4) \cdot \begin{pmatrix} 0,5 & 0,5 \\ 0,7 & 0,3 \end{pmatrix} = (0,58; 0,42)$$

We see that the probability of a vehicle breakdown has increased slightly. In the same way, the results will be processed in the following periods as well. We use equation (15) repeatedly.

$$\vec{p}(4) = \vec{p}(3) \cdot P = (0,58; 0,42) \cdot \begin{pmatrix} 0,5 & 0,5 \\ 0,7 & 0,3 \end{pmatrix} = (0,584; 0,416)$$

$$\vec{p}(5) = \vec{p}(4) \cdot P = (0,584; 0,416) \cdot \begin{pmatrix} 0,5 & 0,5 \\ 0,7 & 0,3 \end{pmatrix} = (0,5832; 0,4168)$$

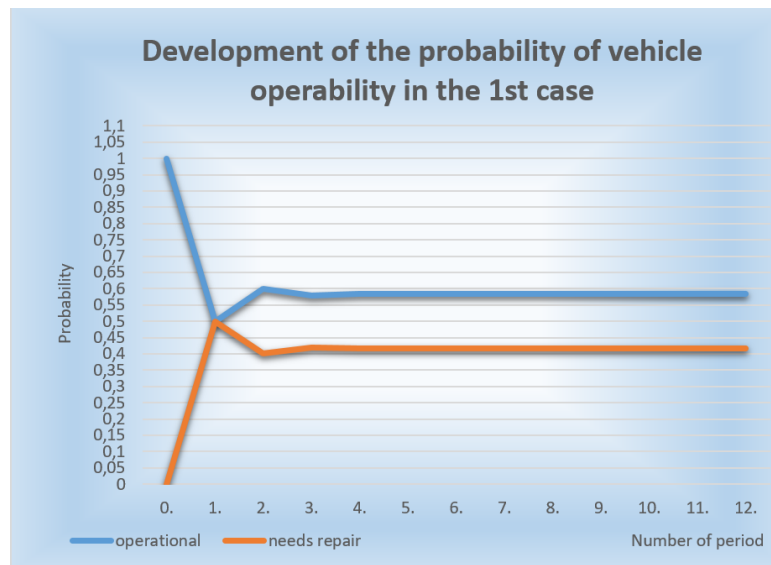

Figure 2: Possibility of vehicle operability in the 1<sup>st</sup> simulation  
(Source: Own processing)

Note that the probability that the type of vehicle under investigation will need to be repaired has not changed much in recent periods. When simulating further periods, we find that this probability does not change significantly. The following figure shows the development of probabilities up to the 12th period. It is obvious that in our simulated example, when we initially consider a serviceable vehicle, the development of probabilities after the third period is already relatively stable (Figure 2).

We would come to similar results if, at the beginning of the simulation, we assumed that we were starting to work with an older car that is currently being repaired. Thus, the considered system would be formed again by states  $s_1$  and  $s_2$ , while at the beginning the car would be in state  $s_2$ . The initial vector of absolute probabilities would change shape:

$$\vec{p}(0) = (0; 1)$$

The development of the probability of vehicle operability in this second model situation is shown in the following figure 3.

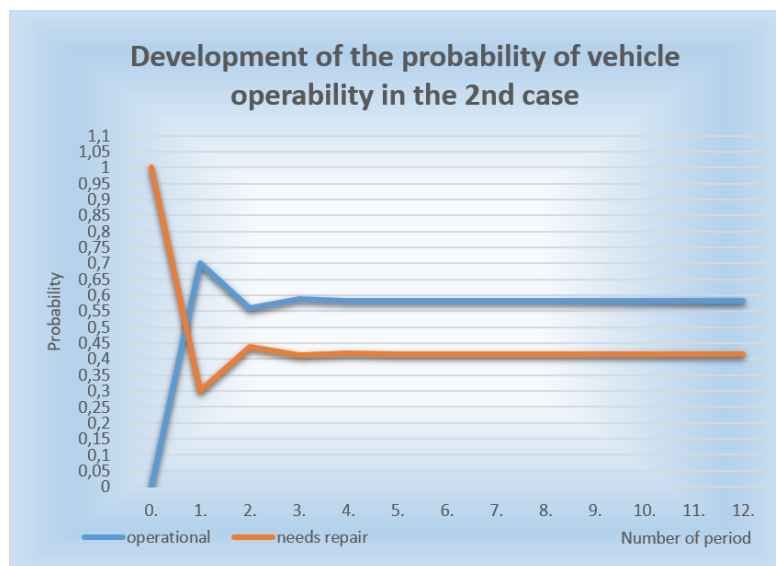

Figure 3: Possibility of vehicle operability in the 2<sup>nd</sup> simulation  
(Source: Own processing)

Again, it can be stated that after the third period there are only slight changes in probability. Both situations can be captured by the following table 2:

Initial state	n	0	1	2	3	4	5
Operational	$p_1(n)$	1	0,5	0,6	0,58	0,584	0,5832
	$p_2(n)$	0	0,5	0,4	0,42	0,416	0,4168
Needs repair	$p_1(n)$	0	0,7	0,56	0,588	0,5824	0,58352
	$p_2(n)$	1	0,3	0,44	0,412	0,4176	0,41648

Table 2: Absolute probability vectors for 5 considered periods in both model examples.  
(Source: Own processing)

In our system, we assumed that the state of operability and the need for repair can occur at any time. By simulation we found that the considered system stabilizes relatively quickly. In the fourth period, it reaches values that change very little. Since both states can recur in subsequent periods, it is possible to determine a limit vector for this system.

In our example:

$$(a_1; a_2) \cdot \begin{pmatrix} 0,5 & 0,5 \\ 0,7 & 0,3 \end{pmatrix} = (a_1; a_2)$$

$$a_1 + a_2 = 1$$

From the created system of equations we determine the coordinates of the stationary vector:

$$0,5a_1 + 0,7a_2 = a_1$$

$$0,5a_1 + 0,3a_2 = a_1$$

$$a_1 + a_2 = 1$$

We express:

$$a_1 = 1 - a_2$$

Substitute into the equation:

$$0,5 \cdot (1 - a_2) + 0,7a_2 = 1 - a_2$$

$$0,5 - 0,5a_2 + 0,7a_2 = 1 - a_2$$

$$1,2a_2 = 0,5$$

$$a_2 = \frac{5}{12}$$

Thus:

$$a_1 = \frac{7}{12}$$

Stationary limit vector values:

$$\vec{a} = \left( \frac{7}{12}; \frac{5}{12} \right) = (0,5833; 0,4167)$$

In our example, we can say that the solved older car will be operational with a probability of 58.33% and in repair with a probability of 41.67%. When comparing the results of the limit vector with the vectors of absolute probabilities, we see that our system stabilizes relatively quickly, as the vectors reach very similar values in the fourth period.

#### 4. CONCLUSION

The presented article presents the possibilities of using the analysis of Markov chains in the form of generating functions in the simple prediction of two theoretical states, into which the process can get after several theoretical periods. The use of generating functions is based on monitoring the development of the process and obtaining data on states that acquire stochastic values. The use of generating functions is mathematically conditioned by determining the transformation of the state to a given pattern - the original. There is a clear representation between the original and the transformed pattern. The example shows a simulation of a simple process in which we observe how an older vehicle behaves in unspecified time periods. The process acquires states where the vehicle is either operational or in need of repair. By applying the generating functions, we found that the process stabilizes quickly and after the fourth period we are able to predict its development with great accuracy. This provides us with a wide range of possibilities for the use of this prediction, especially in business economics and financial planning. It is clear that the simulated example is only theoretical. For more reliable results, it is necessary to obtain results from practical research, which will be carried out in cooperation

with companies from practice. At this point, it should be emphasized that without an economic link to real data from accounting or financial analysis, the application of generating functions for economic needs is very limited. This link will be the subject of further research by the author of the article.

**ACKNOWLEDGEMENT:** *This research was financially supported by the grant of VEGA 1/0121/20: Research of transfer pricing system as a tool to measure the performance of national and multinational companies in the context of earnings management in conditions of the Slovak Republic and V4 countries*

## LITERATURE:

1. Bartosova, V., Kral, P. (2016). *A Methodological Framework of Financial Analysis Results Objectification in the Slovak Republic*. 3rd International Conference on Business and Economics (BE-ci), MALAYSIA, European Proceedings of Social and Behavioural Sciences, 17, 189-197. Retrieved 19.05.2020 from [https://www.futureacademy.org.uk/files/images/upload/17\\_Beci2016.pdf](https://www.futureacademy.org.uk/files/images/upload/17_Beci2016.pdf).
2. Berezny, S. (2015). *Úvod do teórie hromadnej obsluhy. Analýza markovových reťazcov pomocou vytvárajúcich funkcií*. (First edition). Košice, Technická univerzita v Košiciach. Retrieved 25.05.2020 from <http://web.tuke.sk/fei-km/sites/default/files/prilohy/10/THO-P3.pdf>.
3. Hoang, T. C., Joseph, D.M. (2019). *The effect of new corporate accounting regime on earnings management: Evidence from Vietnam*. Journal of International Studies, 12(1), 93-104. Szczecin, Poland. Retrieved 25.05.2020 from [https://www.jois.eu/files/6\\_584\\_Hoang.pdf](https://www.jois.eu/files/6_584_Hoang.pdf).
4. Kapusta, J., Kalasova, A. (2015) *Motor Vehicle Safety Technologies in Relation to the Accident Rates*. In: Mikulski J. (eds) Tools of Transport Telematics. TST 2015. Communications in Computer and Information Science, vol 531. Springer, Cham. Retrieved 15.05.2020 from [https://link.springer.com/chapter/10.1007/978-3-319-24577-5\\_17](https://link.springer.com/chapter/10.1007/978-3-319-24577-5_17).
5. Neuschl, S., Blatny, J., Safarik, J., Zendulka, J. (1988). *Modelovanie a simulácia: Modelovanie systémov hromadnej obsluhy* (First edition). Bratislava: Vydavateľstvo ALFA.
6. Oliver C. I. (2013). *Markov Processes for Stochastic Modeling. 2 - Basic Concepts in Stochastic Processes*. (Second Edition). Elsevier Inc. Retrieved 30.05.2020 from <https://www.sciencedirect.com/book/9780124077959/markov-processes-for-stochastic-modeling?via=ihub=>.
7. Pinsky, A. M., Karlin, S. (2011). *An Introduction to Stochastic Modeling* (Fourth Edition). USA, Elsevier Inc., Academic Press. Retrieved 19.05.2020 from <http://www.sciencedirect.com/science/article/pii/B9780123814166000034>.
8. Poliak, M., Poliakova, A., Tomicova, J., Cheu, K., Fedorko, G. (2019). *The impact of the CMR protocol on carrier competitiveness*. Journal of competitiveness: The scientific periodical published by the Faculty of Management and Economics of Tomas Bata University in Zlin. 11(4). p. 132-143. Retrieved 30.05.2020 from <https://www.cjournal.cz/files/305.pdf>
9. Poliak, M., Poliakova, A., Mrnikova, M., Simurkova, P., Jaškiewicz, M. (2017). *The competitiveness of public transport*. Journal of competitiveness: The scientific periodical published by the Faculty of Management and Economics of Tomas Bata University in Zlin. 9(3). p. 81-97.

10. Rybicka, K., Rybicki, P. (2018). Chosen aspects of it systems in management and accounting in companies under globalization. University of Žilina. *Ekonomicko-manazerske spektrum* 12(2), 57-66. Žilina. Retrieved 20.05.2020 from <https://journals.indexcopernicus.com/api/file/viewByFileId/651725.pdf>.
11. Salaga, J., Bartosova, V., Kicova, E. (2015). Economic Value Added as a Measurement Tool of financial Performance. In *Procedia Economics and Finance*. 26. 484-489. Elsevier Inc. Retrieved 19.05.2020 from <http://www.sciencedirect.com/science/article/pii/S2212567115008771>.
12. Uncovsky, L. (1980). *Stochastické modely operačnej analýzy* (First edition). Bratislava: Vydavateľstvo ALFA.
13. Valaskova, K., Kliestik, T., Misanková, M. (2018). Management of financial risks in Slovak enterprises using regression analysis. In *Oeconomia Copernicana*. 9. 105-121. Institute of Economic Research, Poland.

# KAIZEN COSTING: SYSTEMATIC LITERATURE REVIEW (2015-2020)

**Pedro Miranda**

*ISCAP, Polytechnic of Porto  
Matosinhos, Portugal  
2110426@iscap.ipp.pt*

**Rui Silva**

*CETRAD, University of Trás-os-Monte and d Alto Douro (UTAD)  
Vila Real, Portugal  
rui.silva@utad.pt*

**Amélia Ferreira da Silva**

*CEOS.PP, ISCAP, Polytechnic of Porto  
Matosinhos, Portugal  
acfs@iscap.ipp.pt*

**Carina Ferreira**

*ISCAP, Polytechnic of Porto  
Matosinhos, Portugal  
2190038@iscap.ipp.pt*

## **ABSTRACT**

*This paper aims to identify and describe trends in scientific research, published in the last 5 years, on kaizen costing topics. Given the diversity of scientific approaches and theoretical perspectives under which the theme is studied we carried out a systematic literature review for the last five years. We used a web of Science as a data source. The content analyzes allow us to identify the most concept related to kaizen: Kaikaku, MUDA, PDCA, Six Sigma, Lean Manufacturing, Lean Thinking, Just in Time, Cycle Time, Lead Time, Quality Management and Benchmarking. Moreover, the recent research on the topic is mostly empirical oriented and is applied in developed countries, the industry sector maintaining a huge representation. Despite the limitations and bias inherent in the methodology followed, this study is of great interest to academics who are or intend to investigate the topic and for managers dealing with cost management challenges.*

**Keywords:** *management accounting; cost accounting; hospitals; literature review*

## **1. INTRODUCTION**

Especially from the 90s of the 20th century, kaizen costing has been continuously addressed in both scientific and professional journals. Kaizen costing represents a major change in the way costs are managed. The traditional cost control approach is grounded on the preservation of the status quo. Since costs are maintained under certain limits, things are reported as being well done. Kaizen costing focuses on cost reduction based on quality, productivity, and labor-management relations. Thus, an improvement must be created and implemented every day, to reduce the organization's costs and, at the same time, increase its productivity and quality. In a business world, continuous improvement consists of the repeated efforts made to improve something, whether it be a product, a service, or a process, exposing and eliminating existing problems. As a rule, it implies the realization of small incremental improvements, instead of an overwhelming innovation, which can be seen as an endless search for perfection. Moreover, cost reduction must be aligned with value creation.

The model emerged in Japan, where continuous improvement is the basis of its business culture. Masaaki Imai is the point as the founder of the Kaizen concept and the disseminator of it in the western world, 30 years ago. The word Kaizen has its origin in the Japanese language, the Japanese character "kai" means change and the Japanese character "zen" means improvement. This methodology, recognized as a cultural approach oriented for continuous improvement, has as main objective to provide competitive advantages to the entities where it operates. However, according to Kaizen Institute, 5 principles must be met to guaranty successful implementation: Know your Customer, Let it Flow, Go to Gemba, Empower People and Be Transparent. According to Sani and Allahverdizadeh (2012), kaizen essentially tries to ensure that everyone in the company continually reconsiders how the task is undertaken and whether there is a better way of doing it. It encourages the use of intelligent and shared thought and action through work-teams to search for improvements. The Kaizen methodology has proven to be very useful for long-term strategies of continuous improvement. Many successful cases have been reported in the literature, for example, in airlines (Modarress, Ansari, and Lockwood, 2005), construction (Robert and Granja, 2006) manufacturing (Malloch, 1997; Gupta and Jain, 2014); policing services (Alosani, 2020); make-to-order company (Rossini et al., 2019). This work aims to identify and describe the most recent trends in kaizen costing research. Thus, a systematic review of the literature was carried out, based on articles indexed on the Web of Science platform, in the last five years. In the next chapter, the methodology and procedures applied in the process of collecting, selecting, and reviewing the literature will be described. In chapter 3, the results of the analysis made to scientific publications related to kaizen costing are presented and discussed. Finally, the final considerations will be exposed, in chapter 4.

## **2. METHODOLOGY**

Systematic literature review (SLR) requires the application of very clear and explicit methodological procedures. Currently, researchers have practical guidelines to develop this type of study, namely the Cochrane Handbook; the Preferred Reporting Items for Systematic Reviews and Meta-Analyzes (PRISMA). The application of these procedures to the social sciences requires important adaptations. Our research question is formulated in the following terms: what are the most recent research trends on kaizen costing topic?

The data sources used were the electronic platforms: Web of Science. The data collected was limited to articles published in journals indexed on this platform. We started by experience the search with just one keyword: Kaizen, and without any additional criterion. The system gave us more than eight hundred papers. This search strategy brought us many technical papers related to engineering and similar. Once we were focused on the most recent research trend, we redefined our search for the last 5 years, and selected only “article” as document type and “management” as the scientific area. Thus, we excluded all works published in conference proceedings; all unpublished works, and all works published in journals not available from the selected databases. This search was conducted on April 30, 2020, on the Web of Science platform. From this research, a total of 69 articles were obtained. The graphic 1 shows the publication distribution by the last five years.

*Graphic following on the next page*

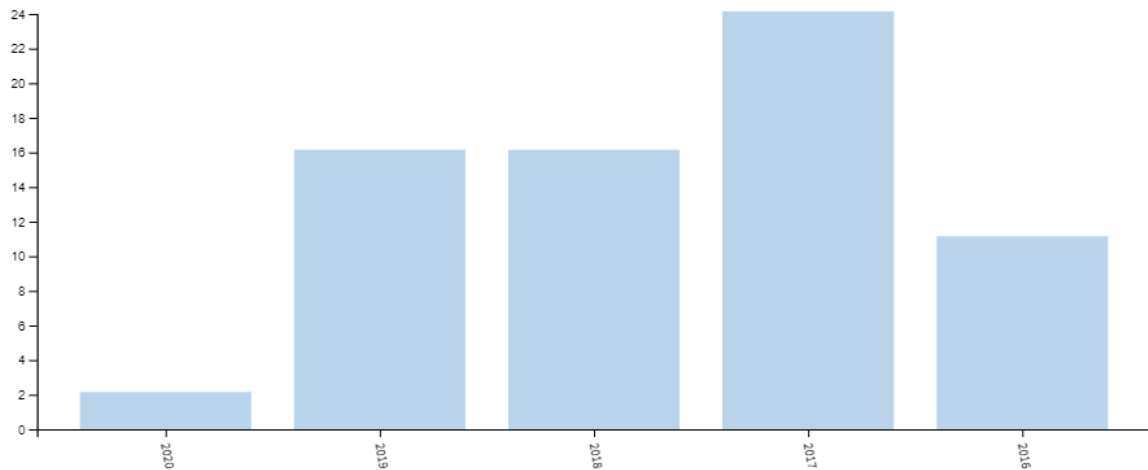

*Graphic 1: Publication by year*

During 2017, there was a significant spike in the number of publications, concerning previous years, which reflects the underlying trend of rising academic coverage of this field.

From picture 1, that follows, it is clear a significant number of publications come from a specialized journal like “Kaizen Planning Implementing and Controlling”, “International Journal of Lean Six Sigma” and International Journal of Productivity and Performance Management.



*Picture 1: Distribution by source title*

A selection process was then carried out, based on the reading of the title and the abstract, disregarding those that did not fit the objective of the study. The research procedures are applied by two researchers, on the same date, but independently. In general, there were no important divergences, and, whenever doubt persists, inclusion is chosen. The dominant criterion was the scope of the article being economic.



This criterion makes it possible to determine which studies are used in content analysis since it is decided that articles that do not meet the criteria for validity should be cited and the reason for their exclusion explained. After this selection process, there was a universe of 40 articles for analysis according to Appendix I - List of analyzed articles. To avoid the exclusion of relevant articles, it is decided to include all articles that offer doubts to at least one of the researchers.

From then on, the analysis of the articles followed a qualitative approach, applying a categorization that allows us to answer three specific research questions:

- What are the research objectives?
- What are the methodologies used?
- What conclusions were obtained?

### 3. RESULTS PRESENTATION AND DISCUSSION

Through the analysis carried out, it is possible to perceive that despite being a Japanese concept, companies from all over the world have been adopting this philosophy quite successfully, combining the best traditional Japanese practices with the strengths of Western practices. In other words, companies have been combining the benefits of teamwork with the creativity of individuals, thus developing competitive advantages in their business area.

Within the 40 papers, Sunder (2016) is the most cited one.

Table 1 presents the result of the research carried out.

Authors	Objective(s)	Methodology	Conclusions
Jagdeep Singh, Harwinder Singh	Uncover the significance of Kaizen technique in manufacturing environments	Questionnaire survey	Failure mode and effect analysis is the most important element of Kaizen
Mahmoud Awad, Yassir A. Shanshal	Propose a new framework for early design stage utilizing Kaizen events and Design for Six Sigma (DFSS)	Case study	For the method to succeed a few key enablers should be available such as management buy-in and support, effective resources utilization, and proper planning
Erez Agmoni	Examine the impact of introducing Kaizen as an ODI tool, how it is applied, how it works and whether participants believe it helps service groups form more effective working relationships that result in significant performance improvements	Archival study and action research case study	Radical improvements in both companies such as 30% financial growth and 81% productivity improvement
Thomas Bortolotti, Stefania Boscari, Pamela Danese, Hebert Alonso Medina Suni,	Identify the most influential determinants of healthcare employees' problem-solving capabilities and attitudes towards Kaizen initiatives and clarify how their determinants are related to social outcomes	Hypothesis tested through regression	Goal clarity, team autonomy, management support, goal difficulty and affective commitment to change are the most influential determinants of Kaizen capabilities and/or employees' attitude

<b>Authors</b>	<b>Objective(s)</b>	<b>Methodology</b>	<b>Conclusions</b>
Nicholas Rich, Pietro Romano			
Manuel F. Suarez-Barraza, Francisco G. Rodriguez-Gonzalez, Howard Stanley Hart	Finding common elements between the Kaizen approach and the standards of North American accrediting associations	Content analysis carried out under the comparison method	7 AACDB standards identified as having Kaizen core values
Ulrica von Thiele Schwarz, Karina M. Nielsen, Terese Stenfors-Hayes, Henna Hasson	Explore the role of Kaizen in improving employee well-being	Multi-group structural equation modeling	Kaizen serves as a mechanism that increases the level of awareness of and capacity to manage psychosocial issues, which in turn increases job satisfaction and mental health, and better integration of organizational and employee objectives, which in turn increases job satisfaction and decreases discomfort
Temitope Seun Omotayo, Udayangani, Kulatunga, Bassam Bjeirmi	Explore the critical success factors and associate drivers of Kaizen associated with the Nigerian construction industry	Questionnaires under the five-point Likert scale format	Confirmed that Kaizen can be adopted in Nigerian construction companies
Muhammad Ihsan, Rofiatul Hasanah, Humiras Hardi Purba	Understanding if Kaizen can improve the performance of machine operators and machine maintenance	Causal analysis	Application of Kaizen showed a decrease in machine engine trouble and a performance boost on the operators, which in turn also increases engine performance
Wagner Cardoso, Edson Bassi, Jessica Fernanda Bertosse, Rafael Mestre Saes, Jorge Alberto Achcar	Demonstrate that Kaizen leads to continuous improvement and cost reduction, through the implementation of 5S's	Case study	Statistical results show that Kaizen does lead to continuous improvement and cost reduction, and that the main purpose of these two tools, Kaizen and 5S's is to improve competitiveness and assure companies sustainability
Chantal Baril, Viviane Gascon, Jonathan Miller, Nadine Cole	Study how a business game can be used jointly with discrete event simulation to test scenarios defined by team members during a Kaizen event to allow a rapid and successful implementation of the solutions developed during Kaizen	Case study	Patient delays were reduced by 74% after 19 weeks

<b>Authors</b>	<b>Objective(s)</b>	<b>Methodology</b>	<b>Conclusions</b>
Roma Mitra Debnath	Represent the implementation of Kaizen in a biscuit-manufacturing unit	Case study	The biscuit-manufacturing unit yield was increased from 88.3% to 92.2%, the product complaints were reduced to zero, the product quality rating increased from 96.7 to 98.2 and the product consistency was improved
Hendro Lukman, Susanto Salim	Demonstrate how Just in Time, Kaizen, Cycle Time and Lead Time with Quality Management System as moderating variables can influence Lean Manufacturing	Case study	First test (independent variables) showed that Just in Time and Cycle Time have no effect on Lean Manufacturing. Second test (independent variables with Quality Management System as moderating variable) showed that Kaizen and Lead Time have a positive influence and that Cycle Time has a negative influence on Lean Manufacturing
Jie Ma, Zhibin Lin, Chi Keung Lau	Understand how Sino-Japanese joint ventures implemented Kaizen, Kaikaku and Kaizen Blitz	Enhanced fuzzy AHP	Personnel factor enablers are the most important factor for Kaizen, software factor enablers weight second, and hardware factor enablers weight last. Study also reviews that Kaizen is the most selected improvement method among the three
Joklan I. C. Goni, Fransisca Tharia, Nugroho Suryo	Examine factors that most strongly influence success in benchmarking	Questionnaire	Success in benchmarking correlates positively with success in Kaizen, people mindset and organizational dimensions
Vinicius Mitsuo Kojima Campos, Synthia Lemos Cotrim, Edwin Vladimir Cardoza Galdamez, Gislaine Camila Lapasini Leal	Applying Kaizen Blitz in a production cell of stamping and spirt processes	Case study	Reduction of machine setup time, reducing lead-time of item processing, the material flow within the production cell and creating conditions for a more flexible management of the production schedule
Midiala Oropesa Vento, Jorge Luis Garcia Alcaraz, Aide Aracely Maldonado	Analyze the effects of both managerial commitment and the professional development of human resources on the benefits obtained from Kaizen	Questionnaire, structural equation model	Managerial commitment has a positive impact on economic benefits and those for human resources. The major contribution of this study is the determination of

<b>Authors</b>	<b>Objective(s)</b>	<b>Methodology</b>	<b>Conclusions</b>
Macias, Valeria Martinez Loya	implementation at the planning stage		dependency measures between these variables
Chi On Chan, Huay Ling Tay	Highlighting the lessons learned from two Kaizen events for productivity improvement in a printing company, suggest how to organize lean tools to improve productivity	Field study involving participant observations	Application of a mix of lean tools resulted in significant productivity improvements of 10-30% in the assembly area of the printing company
Jie Ma, Feng Jiao, Chi Keung Lay, Zhibin Lin	Develop and refine the classic roles of shop floor management and quality control circles in Kaizen, examine the linkage between shop floor management and QCC's and test the relationships among shop floor management, QCC's and long-term Kaizen improvement outcomes	Questionnaire analyzed with the canonical correlation approach	Not all shop floor management tools are could help to identify improvement opportunities, QCC's are effective in addressing large problems and challenging current policies, however, they have low impacts on individual learning
Zakaria Dakhli, Zoubeir Lafhaj, Marc Bernard	Applying Lean Thinking to the bidding phase of a building construction company to improve its bidding outputs	Action-Research	The Lean implementation had positive side-effects on the company's organization and strategy
Ingo Kregel	Critically evaluate whether Kaizen can improve the quality of teaching	Action-Research	Learners in the pilot courses welcomed the intense participation and allowed improvements to elements such as course concepts, course material, presentation style, and content or detail selection. Kaizen could successfully improve course quality, especially in the first two years of newly developed courses
Sharfuddin Ahmed Khan, Mohamad Amin Kaviani, Brian J. Galli, Palvisha Ishtiaq	Study, analyze and implement continuous improvement techniques in an interior design case company	Case study	Implementation reduced projects in pipeline time from 16 to 9 weeks, profit margin increased from 25 to 27%, sales win ratio increased from 11 to 32%, better project and financial forecasting, and 92% of tender submission deadline achievement. Workers developed a habit of clean, tidy and organized workplaces
Manuel F. Suarez- Barraza, Su Mi Dahlgaard-Park,	Discover Muda by applying the affinity or TKJ diagram in Mexican Organizations	An exploratory qualitative	First evidence of Muda in Mexican organizations, Muda of Ohno's classification was

<b>Authors</b>	<b>Objective(s)</b>	<b>Methodology</b>	<b>Conclusions</b>
Francisco G. Rodriguez-Gonzalez, Carolina Duran-Arechiga		study using theoretical sampling	confirmed, new common patterns of Muda arose and the TKJ diagram proved to be an effective tool of quality to detect it
K. Galova, R. Rajnoha, P. Ondra	Identify the most frequently used industrial engineering methods in Czech Republic manufacturing companies, compare the use of individual industrial engineering methods in selected industrial areas	Questionnaire	The most commonly used industrial engineering methods are standardization, Material Requirement Planning, Manufacturing Resource Planning, 5S and Kaizen, the method used depends on the type on the industry in which the company operates, however, the industry does not affect whether or not TQM or MRP are used
Nuruk Fadly Habidin, Suzaituladwini Hashim, Nursyazwani Mohd Fuzi, Mad Ithnin Salleh	Determine the relationship between total productive maintenance, Kaizen event and innovation performance for Malaysian automotive industry	Questionnaire, Structural equation modeling	KE does not affect the relationship between TPM and IP, however, the impact of TPM on IP increases with mediating of KE for Malaysian automotive industry
Temitope Seun Omotayo, Prince Boateng, Oluyomi Osobajo, Adekunle Oke, Loveline Ifeoma Obi	Present a capability maturity model developed to implement continuous improvement in small and medium scale construction companies in Nigeria	Qualitative studies, interviews, system thinking	CMM provided a five-level approach for the inclusion of investigated variables such as team performance, culture, structure, post-project reviews, financial risk management, waste management policy and cost control
Vijaya M. Sunder	Present various quality constructs, their application, success, and shortcomings, in higher education	General review	Quality construct is required in higher education
Manuel F. Suarez-Barraza, Francisco G. Rodriguez-Gonzalez	Investigate cornerstone root causes through the application of CEDs in 40 Mexican companies that began an effort to improve some of their organizational processes	Case study	There were at least 7 typical patterns that show the first signs of cornerstones root causes in organizations
Desmond Eseoghene Ighravwe, Sunday Ayoola Oke	Ranking production lines in a cement plant to benchmark the highest-ranked performer to identify areas where others need improvement	Stepwise weight assessment ratio analysis and fuzzy topics	Results show that the production line 1 had the highest rank and shows potentials of performance enhancement as a benchmarking tool for production systems

<b>Authors</b>	<b>Objective(s)</b>	<b>Methodology</b>	<b>Conclusions</b>
Ibere Guarani de Souza, Daniel Pacheco Lacerda, Luis Felipe Riehs Camargo, Aline Dresch, Fabio Sartori Piran	Analyzing the impact of continuous improvement and teaming processes regarding efficiency and production volume in an armament manufacturer	Survey, longitudinal case study comprising a period of 6 years of analysis, data envelopment analysis combined with ANOVA test and linear regression	Technology upgrade is an important factor, variables related to Kaizen events did not increase the efficiency, in fact, production volume negatively impacted efficiency in one of the lines
Ahmed Mohamed Elsheikh, Mohamed S. Emam, Sultana Ali AlShareef	Discussion about securing a balanced system of current practice and matching documentation	Case study	Document vitalization led to a 16.7% reduction in average time per prescription in inpatient pharmacy and 20% reduction in emergency room pharmacy
Karla Alvarado Ramirez, Victor Pumisacho Alvaro	Evaluate the practices of continuous improvement in medium and large manufacturing companies and services of the Metropolitan District of Quito, examine the benefits and difficulties in sustaining continuous improvement and to study the participation of the different hierarchical organizational levels in the practice of continuous improvement	Exploratory study	Results show a preference for the use of simpler techniques to identify and solve problems such as the seven basic quality tools
Alidiane Xavier, Murilo de Melo Gonzalez	Analyze the overall results of implementing Kaizen philosophy in an automaker of construction machinery	Action research	Continuous improvement activities directly impact the elimination of waste from the assembly process improving efficiency by 30%
Thomas Farrington, Jiju Antony, Kevin D. O’Gorman	Note trends, parallels, inconsistencies, and opportunities towards a clearer understanding of current scholarship	Systematic literature review	Studies of continuous improvement methodologies are published infrequently and tend to focus on TQM in European contexts, identifies clear needs for continuous improvement research with a specific hospitality management focus
Shumpei Iwao, Mihail Marinov	Examine factors that inhibit and facilitate the contribution of continuous improvement activities	Routine dynamics theory	Paper argues that the presence/absence of an incentive to perform

<b>Authors</b>	<b>Objective(s)</b>	<b>Methodology</b>	<b>Conclusions</b>
	to advance performance in lean factories		operations according to the SOP is dependent on whether the responsibility of the performance lies with the SOP or employees, and also that the SOP not only limits employees' creativities but also supports creative activities for the development of continuous improvement as an organizational activity
Jose Carlos Toledo, Rodrigo Valio Dominguez Gonzalez, Fabiane Leticia Lizarelli, Renato Arima Pelegrino	Show the outcomes of an action research that analyzed and developed leadership practices	Action research	Leadership practices implemented were shown to be adequate to the lean production system
Seyed Mojib Zahraee	Identify effective practices and tools of lean manufacturing implementation in an Iranian Manufacturing industry	Questionnaire	Processes and equipment, planning and control, supplier relationship, human resources, and customer relations are significant practices in lean manufacturing in Iranian manufacturing companies
Keivan Zokaei, Ioannis Manikas, Hunter Lovins	Review how the field of lean and green has been evolving	Literature review, benchmarking	There is no trade-off between lean and green, lean and green should be brought together in a symbiosis which requires a strategy that is well developed and well deployed across all levels of business
Martin Christopher Saier	Investigating the beginning of project management with a focus on business models similar to the PDCA cycle, to find an approach which could be used as a new standard procedure for the eradication of projects in Lean project management, CPD	Literature review, interviews	CPD is a Lean variant of the Ian Do Check Act, CPD cycle can be used on different planning levels in analogy to the hoshin kanri logic

<b>Authors</b>	<b>Objective(s)</b>	<b>Methodology</b>	<b>Conclusions</b>
Matloub Hussain, Raid Al-Aomar, Hussein Melhem	Empirically assess the impact of integrated lean and green practices on the sustainable performance of a hotel supply chain	Literature review, case study	Kaizen, quality, productive maintenance, health and safety, waste disposal, and green certifications have a substantial impact on the sustainable performance of hotel supply chains, LeGreen impacts are complementary. Lean techniques have the highest impact on economic performance and the least impact on environmental performance. Green practices have opposite impacts
Ashish Thomas	Explore how to harness the power of an integrated system of quality tools and techniques to create operational excellence	Literature review, interviews, case study	Quality systems in a complex competitive environment must consider an integrated iterative approach, an iterative development of lean quality tools for multiple phases produces an integrated quality system

*Table 1: Qualitative analyses of literature*

The most studied theme is the Kaizen in the industrial sector, of the 40 articles, 23 dealt with this reality. The research is developed in high different companies from different countries, mainly in developing countries. The main purpose of the authors is to identify, if, and in what way, Kaizen influences the production processes. Several authors explored the impact of holding Kaizen events at different stages of the production process, namely the design, planning, and production phases. Some authors have also chosen to focus their study on the factors that contribute to the success of these initiatives. To a large extent, studies focus on improving performance, associated with operations and their maintenance, with a focus on reducing costs, increasing production, quality of service, and customer satisfaction. However, the well-being of employees also had an important focus in several studies, in these cases, the majority try to analyze the subsequent impact of these events, not only in the production process but also in the development of human resources. Although the origin of Kaizen is associated with production processes, its application has been extended to several other sectors. Of the 40 articles analyzed, 12 study the application of this concept to service sectors, namely the health, education, hospitality, project management, and audit sectors, among others. In general, the authors opted for an approach that analyses the successful implementation of Kaizen, together with other quality management tools, such as, for example, MUDA, PDCA, Six Sigma, Lean Manufacturing, Lean Thinking, Just in Time, Cycle Time, Lead Time, Quality Management and Benchmarking. The main contribution of these articles is practical, with only one of the analyzed articles proposing a new framework, the creation of a new procedure, the Check Plan Do, which is a Lean variation of the Plan Do Check Act.

#### **4. CONCLUSION**

The content analysis carried out on the articles showed that in addition to the best-known applications of Kaizen events in the industrial sector, they can be successfully applied in the



service sectors. It was also possible to identify the main factors that contribute to the success of these events, namely management buy-in and support, the effective use of resources, and assertive planning. Also, it was possible to determine that the realization of these events has a positive transversal impact on the organization, not only in its production process but also in terms of cost reduction, quality of service, customer satisfaction, well-being of customers, employees and the development of human resources. Finally, it is important to note that most of the articles analyzed were published by international newspapers, namely the International Journal of Quality & Reliability Management, the International Journal of Productivity and Performance Management, the International Journal of Lean Six Sigma, and the International Journal of Quality and Service Sciences. In future studies, it would be interesting to extend the research to a longer period, also resorting to the use of other keywords, in order to better relate the practical application of the different quality management tools. It may also be interesting to conduct a study about the origins of these tools and the way they have evolved over the years.

**ACKNOWLEDGEMENT:** *This work is financed by Portuguese national funds through FCT - Fundação para a Ciência e Tecnologia, under the project UIDB/05422/2020*

#### LITERATURE:

1. Alosani, M. S. (2020). Case example of the use of Six Sigma and Kaizen projects in policing services. *Teaching Public Administration*, 0144739420921932.
2. Gupta, S., & Jain, S. K. (2014). The 5S and kaizen concept for overall improvement of the organization: a case study. *International Journal of Lean Enterprise Research*, 1(1), 22-40.
3. Malloch, H. (1997). Strategic and HRM aspects of kaizen: a case study. *New Technology, Work and Employment*, 12(2), 108-122.
4. Modarress, B., Ansari\*, A., & Lockwood, D. L. (2005). Kaizen costing for lean manufacturing: a case study. *International Journal of Production Research*, 43(9), 1751-1760.
5. Robert, G. T., & Granja, A. D. (2006, July). Target and kaizen costing implementation in construction. In *Annual Conference of the International Group for Lean Construction* (Vol. 14).
6. Sani, A. A., & Allahverdizadeh, M. (2012). Target and kaizen costing. *World Academy of science, engineering, and technology*, 6(2), 40-46.

#### APPENDIX: LIST OF ANALYZED ARTICLES

1. Agmoni, E. (2015). The role of Kaizen in creating radical performance results in a logistics service provider. *Logforum*, 12(3), 225–245. <https://doi.org/10.17270/J.LOG.2016.3.4>
2. Awad, M., & Shanshal, Y. A. (2017). Utilizing Kaizen process and DFSS methodology for new product development. *International Journal of Quality and Reliability Management*, 34(3), 378–394. <https://doi.org/10.1108/IJQRM-09-2014-0139>
3. Baril, C., Gascon, V., Miller, J., & Côté, N. (2016). Use of a discrete-event simulation in a Kaizen event: A case study in healthcare. *European Journal of Operational Research*, 249(1), 327–339. <https://doi.org/10.1016/j.ejor.2015.08.036>
4. Bortolotti, T., Boscarri, S., Danese, P., Medina Suni, H. A., Rich, N., & Romano, P. (2018). The social benefits of kaizen initiatives in healthcare: an empirical study. *International Journal of Operations and Production Management*, 38(2), 554–578. <https://doi.org/10.1108/IJOPM-02-2017-0085>

5. Campos, V. M. K., Cotrim, S. L., Galdamez, E. V. C., & Leal, G. C. L. (2016). Introduction of Lean Manufacturing Philosophy by Kaizen Event: Case Study on a Metalmechanical Industry. *Independent Journal of Management & Production*, 7(1), 151–167. <https://doi.org/10.14807/ijmp.v7i1.388>
6. Cardoso, W., Bassi, E., Bertosse, J. F., Saes, R. M., & Achcar, J. A. (2018). The implementation and use of the “5s” and Kaizen program for the management of sewing offices of a middle family company. *Independent Journal of Management & Production*, 9(3), 767–784. <https://doi.org/10.14807/ijmp.v9i3.726>
7. Chan, C. O., & Tay, H. L. (2018). Combining lean tools application in kaizen: a field study on the printing industry. *International Journal of Productivity and Performance Management*, 67(1), 45–65. <https://doi.org/10.1108/IJPPM-09-2016-0197>
8. Dakhli, Z., Lafhaj, Z., & Bernard, M. (2017). Application of lean to the bidding phase in building construction: A French contractor’s experience. *International Journal of Lean Six Sigma*, 8(2), 153–180. <https://doi.org/10.1108/IJLSS-03-2016-0010>
9. de Souza, I. G., Lacerda, D. P., Camargo, L. F. R., Dresch, A., & Piran, F. S. (2018). Do the improvement programs really matter? An analysis using data envelopment analysis. *BRQ Business Research Quarterly*, 21(4), 225–237. <https://doi.org/10.1016/j.brq.2018.08.002>
10. Elsheikh, A. M., Emam, M. S., & AlShareef, S. A. (2017). Bridging the gap between documents and practice in medication management “Documents Vitalization.” *Business Process Management Journal*, 23(4), 830–841. <https://doi.org/10.1108/BPMJ-02-2017-0030>
11. Farrington, T., Antony, J., & O’Gorman, K. D. (2018). Continuous improvement methodologies and practices in hospitality and tourism. *International Journal of Contemporary Hospitality Management*, 30(1), 581–600. <https://doi.org/10.1108/IJCHM-03-2017-0141>
12. Gálová, K., Rajnoha, R., & Ondra, P. (2018). The use of industrial lean management methods in the economics practice: An empirical study of the production companies in the Czech Republic. *Polish Journal of Management Studies*, 17(1), 93–104. <https://doi.org/10.17512/pjms.2018.17.1.08>
13. Goni, J.I.C., Tharia, F. and Suryo, N. (2018). An empirical study on relationships amongst success in benchmarking, success in Kaizen, people mindset and organizational dimensions. *Benchmarking: An International Journal*, 25(9), 3505–3518. <https://doi.org/10.1108/BIJ-04-2017-0080>
14. Habidin, N. F., Hashim, S., Fuzi, N. M., & Salleh, M. I. (2018). Total productive maintenance, kaizen event, and performance. *International Journal of Quality and Reliability Management*, 35(9), 1853–1867. <https://doi.org/10.1108/IJQRM-11-2017-0234>
15. Hussain, M., Al-Aomar, R., & Melhem, H. (2019). Assessment of lean-green practices on the sustainable performance of hotel supply chains. *International Journal of Contemporary Hospitality Management*, 31(6), 2448–2467. <https://doi.org/10.1108/IJCHM-05-2018-0380>
16. Ighravwe, D. E., & Oke, S. A. (2020). Sustenance of zero-loss on production lines using Kobetsu Kaizen of TPM with hybrid models. *Total Quality Management and Business Excellence*, 31(1–2), 112–136. <https://doi.org/10.1080/14783363.2017.1415754>
17. Ihsan, M., Hasanah, R., & Purba, H. H. (2019). Fanuc CNC machine damage analysis using the PDCA cycle and Kaizen implementation effort in increasing skill up operator performance in PT YPMI. *Independent Journal of Management & Production*, 10(1), 259–280. <https://doi.org/10.14807/ijmp.v10i1.590>

18. Iwao, S. and Marinov, M. (2018). Linking continuous improvement to manufacturing performance. *Benchmarking: An International Journal*, 25(5), 1319-1332. <https://doi.org/10.1108/BIJ-06-2015-0061>
19. Khan, S. A., Kaviani, M. A., J. Galli, B., & Ishtiaq, P. (2019). Application of continuous improvement techniques to improve organization performance: A case study. *International Journal of Lean Six Sigma*, 10(2), 542–565. <https://doi.org/10.1108/IJLSS-05-2017-0048>
20. Kregel, I. (2019). Kaizen in university teaching: continuous course improvement. *International Journal of Lean Six Sigma*, 10(4), 975–991. <https://doi.org/10.1108/IJLSS-08-2018-0090>
21. Lukman, H., & Salim, S. (2016). Factors Influencing Implementation of Lean Manufacturing: Case on Manufacturing in Indonesia. *Managing the Asian Century*, 47–58. [https://doi.org/10.1007/978-981-10-2281-4\\_4](https://doi.org/10.1007/978-981-10-2281-4_4)
22. Ma, J., Jiao, F., Lau, C. K., & Lin, Z. (2018). The relationships between shop floor management and QCCs to support Kaizen. *International Journal of Quality and Reliability Management*, 35(9), 1941–1955. <https://doi.org/10.1108/IJQRM-09-2017-0192>
23. Ma, J., Lin, Z., & Lau, C. K. (2017). Prioritising the enablers for the successful implementation of Kaizen in China: a Fuzzy AHP study. *International Journal of Quality & Reliability Management*, 34(4), 549–568. <https://doi.org/10.1108/IJQRM-12-2015-0173>
24. Mitra Debnath, R. (2019). Enhancing customer satisfaction using Kaizen: a case study of Imperial Tobacco Company (ITC). *Journal of Advances in Management Research*, 16(3), 277–293. <https://doi.org/10.1108/JAMR-01-2018-0009>
25. Mojib, S. (2016). A survey on lean manufacturing implementation in a selected manufacturing industry in Iran. *International Journal of Lean Six Sigma*, 7(2), 136–148.
26. Omotayo, T.S., Boateng, P., Osobajo, O., Oke, A. and Obi, L.I. (2019). Systems thinking and CMM for continuous improvement in the construction industry. *International Journal of Productivity and Performance Management*, 69(2), 271-296. <https://doi.org/10.1108/IJPPM-11-2018-0417>
27. Omotayo, T.S., Kulatunga, U. and Bjeirmi, B. (2018). Critical success factors for Kaizen implementation in the Nigerian construction industry. *International Journal of Productivity and Performance Management*, 67(9), 1816-1836. <https://doi.org/10.1108/IJPPM-11-2017-0296>
28. Ramírez, K. A., & Álvaro, V. P. (2017). Prácticas de mejora continua, con enfoque Kaizen, en empresas del distrito metropolitano de Quito: Un estudio exploratorio. *Intangible Capital*, 13(2), 479–497. <https://doi.org/10.3926/ic.901>
29. Saier, M. C. (2017). Going back to the roots of W.A. Shewhart (and further) and introduction of a new CPD cycle. *International Journal of Managing Projects in Business*, 10(1), 143–166. <https://doi.org/10.1108/ijmpb-11-2015-0111>
30. Singh, J., & Singh, H. (2016). Enigma of KAIZEN approach in Manufacturing Industry of Northern India- A Case Study. *International Journal of Quality & Reliability Management*, 35(1), 187–207. <https://doi.org/10.1108/IJQRM-12-2016-0220>
31. Suárez-Barraza, M. F., & Rodríguez-González, F. G. (2019). Cornerstone root causes through the analysis of the Ishikawa diagram, is it possible to find them?: A first research approach. *International Journal of Quality and Service Sciences*, 11(2), 302–316. <https://doi.org/10.1108/IJQSS-12-2017-0113>
32. Suárez-Barraza, M. F., Dahlgaard-Park, S. M., Rodríguez-González, F. G., & Durán-Arechiga, C. (2016). In search of “Muda” through the TKJ diagram. *International Journal of Quality and Service Sciences*, 8(3), 377–394. <https://doi.org/10.1108/IJQSS-04-2016-0028>
33. Suárez-Barraza, M. F., Rodríguez-González, F. G., & Stanley Hart, H. (2019). Finding Kaizen core values in AACSB standards accreditation: a conceptual study. *Total Quality*

- Management and Business Excellence*, 30(sup1), S53–S73.  
<https://doi.org/10.1080/14783363.2019.1665793>
34. Sunder, M. V. (2016). Constructs of quality in Higher Education services. *International Journal of Productivity and Performance Management*, 65(8), 1091–1111.  
<http://doi.org/10.1108/IJPPM-05-2015-0079>
  35. Thomas, A. (2018). Developing an integrated quality network for lean operations systems. *Business Process Management Journal*, 24(6), 1367–1380. <https://doi.org/10.1108/BPMJ-02-2018-0041>
  36. Toledo, J. C., Gonzalez, R. V. D., Lizarelli, F. L., & Pelegrino, R. A. (2019). Lean production system development through leadership practices. *Management Decision*, 57(5), 1184–1203. <https://doi.org/10.1108/MD-08-2017-0748>
  37. Vento, M. O., Alcaraz, J. L. G., Macías, A. A. M., & Loya, V. M. (2016). The impact of managerial commitment and kaizen benefits on companies. *Journal of Manufacturing Technology Management*, 27(5), 692–712. <https://doi.org/10.1108/JMTM-02-2016-0021>
  38. von Thiele Schwarz, U., Nielsen, K. M., Stenfors-Hayes, T., & Hasson, H. (2017). Using kaizen to improve employee well-being: Results from two organizational intervention studies. *Human Relations*, 70(8), 966–993. <https://doi.org/10.1177/0018726716677071>
  39. Xavier, A., & Gonzalez, M. D. M. (2016). Analysis and improvement of production efficiency in a construction machine assembly line. *Independent Journal of Management & Production*, 7(5), 606–626. <https://doi.org/10.14807/ijmp.v7i5.453>
  40. Zahraee, S.M. (2016). A survey on lean manufacturing implementation in a selected manufacturing industry in Iran. *International Journal of Lean Six Sigma*, 7(2) 136–148. <https://doi.org/10.1108/IJLSS-03-2015-0010>
  41. Zokaei, K., Manikas, I. and Lovins, H. (2017). Environment is free; but it's not a gift. *International Journal of Lean Six Sigma*, 8(3) 377–386. <https://doi.org/10.1108/IJLSS-01-2017-0004>

## US PRESIDENTS AS FOREIGN POLICY ACTORS: GEORGE W. BUSH AND BARACK OBAMA

**Tesa Klopotan**

*Master of Political Science*

*University of Zagreb, Faculty of Political Science*

*tklopotan15@gmail.com*

### **ABSTRACT**

*In this paper, the author compares President George W. Bush's foreign policy with President Barack Obama's foreign policy. The comparison of their foreign policies is based on three key points: unilateralism vs. multilateralism in their foreign policies towards the UN and towards NATO, and their tendency towards using force. Having in mind that the president's role in American foreign policy-making process is claimed to be bigger and more important than the role of other actors, one may refer to the American foreign policy as a certain president's foreign policy. Based on the comparison of Bush's and Obama's foreign policies, it can be concluded that President Obama made a turn when compared to President Bush because he embraced multilateralism. However, it cannot be said that President Obama was less prone to using force because of his intervention in Libya and use of drones against the ISIS. The main difference between them is the way in which they were using force. While Bush was acting unilaterally, Obama embraced multilateral action.*

**Keywords:** *foreign policy, George W. Bush, Barack Obama, UN, NATO, use of force*

### **1. INTRODUCTION**

Since the Cold War, American foreign policy has been marked by an increasing engagement in international relations. With its status of superpower, United States were taking over broad global obligations which led to a permanent foreign policy dilemma. On the one hand, it was considered that America has to fulfil its global obligations and continue to strengthen its influence because no other country had greater political, military and economic power and resources to accomplish its goals abroad. On the other hand, it was considered that American engagement needs to be reduced and American interests and influences need to be directed towards areas crucial to American national security (Vukadinović, 1971). One of the global obligations of the US is to spread democracy abroad, present since the Cold War when foreign policy goals were to spread democracy and prevent the spread of communism, which is the result of the idea that democracy abroad contributes to American security and prosperity. That foreign policy goal is also present in more recent history. While the foreign policy of President George W. Bush was promoting democracy towards war on terrorism, President Barack Obama advocated every country's right to choose its own political organization and was highlighting a common interests-based alliance and not necessarily a common political organization. However, during the Arab Spring, President Obama has occasionally emphasized the need for political reforms in Arab states, believing that instability is the result of rejecting the reforms (Bouchet, 2013). In this paper, the author compares foreign policies of two US presidents – George W. Bush and Barack Obama, in order to show whether American foreign policy has changed with the change of administration and whether some aspects remain the same. After the 9/11 terrorist attacks, the main concern of President Bush's administration were security challenges and war on terrorism. Because of Bush's unilateralism, the main concern of President Obama's administration was the decline of American popularity abroad and the need for strengthening and rebuilding alliances. Their foreign policies will be compared on the points of unilateralism vs. multilateralism in foreign policies towards the UN and NATO and on their

tendency towards using force. Most authors agree that the US president has been dominant in foreign policy decision-making since the end of World War II because of the constitutional interpretations of the Supreme Court, according to which the president represents the country abroad. Since World War I, the presidents conducted personal diplomatic activity and created their own doctrines which they represented personally. Another reason is that presidents often dragged the state into war without prior or subsequent approval from Congress, and even if Congress formally declared war, the President has, in a state of war, the broadest decision-making powers. Having that in mind, the president's role in American foreign policy-making process is bigger and more important than the role of other actors, so one may refer to the American foreign policy as a certain president's foreign policy (Visković, 2007). In the first part of this paper, President Bush's foreign policy towards the UN, NATO and his tendency towards using force is described. In the second part of paper, President Obama's foreign policy is described based on the same three key points and compared to President Bush's foreign policy. Based on President Bush's foreign policy towards the UN and NATO, one can conclude that he was prone to unilateral action, unlike President Obama who embraced multilateral action and a diplomatic approach. Having that in mind, Obama's foreign policy seems more peaceful than Bush's. Considering the fact that Bush's foreign policy was marked by war on terrorism and interventions abroad and the fact that Obama's administration has intervened in Libia and that American forces trained and equipped Syrian rebel forces, it cannot be said that Obama was less prone to using force than Bush. The main difference between them is the way in which they were using force. While Obama believed in the need for approval from multilateral institutions, Bush thought that America can intervene even without multilateral approval, with the help of the coalition of the willing.

## **2. FOREIGN POLICY OF GEORGE W. BUSH**

### **2.1. Unilateralism in foreign policy**

Even before September 11th 2001, a day marked by an unprecedented terrorist attack on a number of buildings in the US, including the Twin Towers in New York and the Pentagon, President Bush was showing he is prone to unilateral action because he refused to ratify the Kyoto Protocol on global warming and because of his unilateral threat of withdrawal from the Anti-Ballistic Missile Treaty from 1972. The European Union had considered it a provocation which could lead to a new arms race, so he received criticism from European countries (Dumbrell, 2002). After 9/11, European states were concerned because of Bush's statement in which he has called Iran, Iraq and North Korea the axis of evil and a threat to the world security and peace. France and Germany were particularly concerned because of his ignoring of the allies. It was not clear how the war on terrorism became a war on weapons of mass destruction and included the countries which had no clear connection with the terrorist attack (Dumbrell, 2002). Bush's unilateralism has created a crisis in transatlantic relations, but Bush and his advisors were convinced that, although their allies may not agree with the way the US handles things, they will eventually shift to their side. Bush's doctrine of preventive attack was first applied in Afghanistan, after the UN approved all that was necessary to respond to the terrorist attacks. For the first time in history, NATO has activated Article 5 stating that the attack on one member is the attack on all members of alliance and that the alliance will defend its members. The US Congress has approved Bush's use of necessary and appropriate force against the states, organizations or persons involved or associated with the 9/11 attacks (Lindsay, 2011).

#### *2.1.1. Foreign policy towards the UN*

After 9/11, the United States reported to the UN Security Council on the measures taken and sought approval from the UN and NATO, while also seeking to establish a coalition to fight terrorism through diplomacy. The US and its allies have managed to secure good legal support

for their actions, while the justification for the use of military force has been found in the claim that it was necessary self-defence. Bush has justified the bombing in Afghanistan as a measure well-suited to the challenge posed by the terrorist attacks. In addition to the importance of the UN role in ensuring the legality of the war, it also had political significance for European allies, Russia and China, which emphasized the importance UN's central role (Hurrell, 2002). After the end of the war in Afghanistan and the relatively rapid decline of the Taliban regime, European states played a central role in peacekeeping, humanitarian aid and post-war reconstruction, and played an important role in the establishment of a post-war government. However, the UN was responsible for establishing a provisional government. The UN-backed Bonn Peace Agreement was soon reached, forming an interim Afghani government, and international security forces under the UN were tasked with overseeing the transition process. There was also the establishment of a multilateral peacekeeping mission during the conflict between Israel and Palestine, made up of the US, Russia, the European Union and the UN (Peterson, 2002).

The war in Iraq has created divisions between the United States and some members of the European Union, but it has also divided the European Union itself. While France and Germany were the main opponents of the war, Britain, Italy, Portugal and Spain gave their support to Washington. After the US shifted its focus from the military campaign to establishing a legitimate and stable government in Iraq, additional divisions were created as France and Germany demanded a central role for the UN, especially France, which emphasized that only the UN should have this task. On the other hand, Bush believed that the UN should have a limited role in post-war Iraq because, in his view, the UN needed serious reforms before it could be handed major responsibilities, while the US assumed too much responsibility with a preventative war and should play a leading role in post-war Iraq (Young i Crawford, 2004).

Since the UN Security Council did not support Bush's military action in Iraq, the administration challenged the role and status of the UN. Secretary of State Colin Powell, who stressed the importance of US cooperation with the UN, felt betrayed after Russia and France refused to support US policy on Iraq in the Security Council. At the same time, the lack of co-operation within the UN has strengthened the position of Powell's opponents during the Bush administration - John Bolton and Dick Cheney - who used the Security Council's blocking on this issue to advocate direct and unilateral US action against Iraq. France and Germany have argued for the UN to have a central role in post-war Iraq in order to legitimize US policy but also to protect economic ties in Iraq, but Bush argued that the role of the UN was necessary but also limited, and implemented a program to manage the transition to a new Iraqi Pentagon-led government. Meanwhile, the US has been in charge of key positions in Iraq, including oil. After the Iraqi regime fell and the war ended, Bush asked the UN to lift sanctions on Iraq so that a post-war regime could be established. France first threatened to abstain from voting in the Security Council, but after being given a greater overseeing role by the UN, they voted to lift sanctions on Iraq (Young i Crawford, 2004). After Iran threatened to exit the negotiations with European countries and restore nuclear development in late 2005, President Bush insisted that the problem be presented to the UN Security Council. Also, in 2006, the administration offered to negotiate with Iran about the future of Iraq. Bush announced the need to further counter the Iranian threat, which represented a dramatic turnaround over earlier statements about Iran as the axis of evil. In 2005, he began negotiations with North Korea to provide energy assistance and normalize relations in exchange for leaving the nuclear program. Even though the negotiations failed, they were a major step forward (Gordon, 2006).

### *2.1.2. Foreign policy towards the NATO*

The 9/11 challenged NATO's role as the US spent ten times more on defence than Britain, which was second in line for defence spending within the Alliance. The 9/11 terrorist attacks were also a challenge for the EU countries, as they needed to show solidarity with the US and respond unanimously. Immediately after the attack, they jointly announced that they would stand side by side with the US (Peterson, 2002). On September 12, 2001, NATO activated Article 5 of the NATO Charter stating that the attack on one member is the attack on all members of the Alliance and that the Alliance will defend its members. The NATO also presented President Bush with a proposal listing possible military functions that he could pursue in the fight against terrorism in Afghanistan. However, differences have emerged among NATO members regarding the course of action and the role of NATO in security challenges. Bush was prepared to accept NATO's contribution as long as it did not threaten the ultimate US goal of destroying Al-Qaeda's headquarters, arresting its leaders and overthrowing the Taliban regime, so he eventually declined direct assistance, and the United States had prepared operations in Afghanistan with the assistance of several allies. US Secretary of Defense Donald Rumsfeld said in an attempt to define the war on terrorism and modifications of military operations that the mission would define the coalition, not the other way around, which was a blow to NATO (Hoehn i Harting, 2010).

In the fall of 2001, the United States launched an independent war in Afghanistan, rejecting European aid in the form of military means and with indirect support from NATO, as they sought to avoid possible alliance restrictions that could hamper efforts to achieve the goals quickly. Because of this, criticisms of Bush's unilateralism began, especially by France and Germany. The European Union was ready to support its military campaign, as long as it was limited only to Afghanistan (Peterson, 2002). Bush, with the help of a coalition of the willing, wanted to achieve his goals and gain operational control in Afghanistan. The purpose of the Afghanistan invasion was to prevent terrorists from using their bases in the Afghan territory and to attack the military resources of the Taliban regime. First, Bush demanded that Afghan leader Mullah Omar surrender Osama bin Laden to the United States, and since he refused, the United States, with the help of forces from nearly twenty countries, attacked Afghanistan (Lindsay, 2011).

After the end of the war and the fall of the Taliban regime, European states were given a central role in peacekeeping, humanitarian aid and post-war reconstruction, and played an important role in establishing a post-war government (Peterson, 2002). Shortly after the end of the war, the Bonn peace treaty, which established an interim Afghan government, was reached and international security forces under the UN were tasked with overseeing the transition process. Given the fact that most of the countries participating in the mission were NATO members, the idea that the Alliance could play a greater role in the mission had spread. In early 2003, the Netherlands and Germany requested NATO's support in planning, logistics, communication and intelligence, which France initially opposed, but members agreed that NATO should assume greater responsibilities in Afghanistan (Hoehn i Harting, 2010). Most allies believed that Bush decided to invade only Afghanistan, while in reality he pursued an "Afghanistan first" strategy, and after the Taliban regime was overthrown, he turned to Iraq (Lindsay, 2011). The Bush's administration was considering a possibility of using force to overthrow Saddam Hussein's regime in Iraq, and NATO was divided over whether it should be involved in Iraq at all. France and Germany opposed this, claiming that if there is a weapon of mass destruction, it must first be located, and that any action requires UN approval. They thought that the war would increase rather than reduce the dangers. Given NATO's split, a new coalition of the willing has been created (Hoehn i Harting, 2010).



After the victory in Iraq, criticism subsided, but gained momentum again after the US failed to find the weapons of mass destruction, which was the central justification for the war. After the French President Jacques Chirac showed his willingness to approve a US-led NATO peacekeeping mission and involve French troops in it, Bush appeared open to NATO's role in post-war Iraq, but continued to build relations with European countries which initially supported the war. The victory in Iraq allowed expansion of US influence in the region, promoting democratic reforms and reviving the Middle East peace process, but after Bush's decision to unilaterally reconstruct post-war Iraq, numerous criticisms around the world have emerged and many Arab and European states had doubts about the real cause of the war in Iraq (Young i Crawford, 2004).

### **2.3. Tendency towards using force**

After 9/11, President Bush felt it was the responsibility of the US to respond to the attacks and free the world of harm. However, he did not want to respond defensively and passively, but by attacking terrorist bases and terrorist states. In his 2002 speech in Congress, Bush called Iran, Iraq and North Korea the axis of evil and stressed that the United States would not allow the world's most dangerous regimes to threaten with weapons of mass destruction. He believed that the United States was militarily dominant enough to act unilaterally, without the help of allies, as evidenced by his statement: "At some point we may be the only ones left. That's OK. We are America." (Woodward, 2002: 81, as quoted in Lindsay, 2011: 767). After the terrorist attacks of 9/11/ George W. Bush determined a revolutionary foreign policy that marked the beginning of America's war on terrorism. The administration considered American power to be the cornerstone of the global order, and the spread of democracy and freedom are key to establishing a safe and peaceful world (Gordon, 2006). After the terrorist attacks, Bush instituted the doctrine of preventative war against a hostile state or terrorist group to deter any potential attack, a unilateral action in which the US would act alone if necessary, and to spread democracy and freedom around the world (Gregg II, 2019).

After 9/11, Bush and his advisers debated whether to invade Iraq immediately, but decided that the doctrine of preemptive strike would first be applied in Afghanistan. Although President Bush initially ruled out the possibility of the war spreading to Iraq, he left the issue open until the situation in Afghanistan stabilized (Gregg II, 2019). Despite the fact that intelligence agencies did not find evidence which would link Iraqi leader Saddam Hussein and Al-Qaeda, Bush believed they were connected. Prominent members of the Bush administration had been giving numerous interviews and public speeches to reassure the public that Iraq owns weapons of mass destruction that pose an unacceptable threat to the United States. In 2002, the US Congress approved the war on Iraq, and Bush sought approval from the UN. He thought the approval would increase public support and put more pressure on Iraq, although he did not really believe he needed it. Since the UN did not give its approval for the attack, Bush attacked Iraq in March 2003 with a "coalition of the willing" (not NATO, which did not agree on the issue), with criticism from around the world (Lindsay, 2011).

Given his initial distance from the Allies that led to high costs, military overload, lack of international legitimacy and support from the US public, Bush set a different foreign policy direction in his second term in order to stabilize the situation. The failure in Iraq and Afghanistan has been compounded with other mistakes, such as forcing free and fair elections throughout the Middle East, where it seems that the administration did not think about what would happen if radical Islamists win the election. The war on terror has also alienated allies in Europe and Latin America over time.

Yet Bush has developed good relations with India, increased foreign aid to Africa in the fight against AIDS, and succeeded in convincing the Libyan leader to abandon the program of developing weapons of mass destruction. Nevertheless, toward the end of Bush's term, global support for the US was constantly low. Bush's main foreign policy contributions are not military action, but the fact that he has signed more free trade agreements than any other US president (Drezner, 2013).

### **3. FOREIGN POLICY OF BARACK OBAMA**

#### **3.1. Multilateralism in foreign policy**

After taking office in January 2009, President Barack Obama had vowed to change the basis of foreign policy over his predecessor, President Bush whose foreign policy has exhausted US resources and cooled US relations with much of the world, especially the Muslim states. For the first two years, Obama was burdened with defining national security challenges concerning the wars in Afghanistan and Pakistan, the proliferation of Iran's nuclear weapons, the Israeli-Palestinian conflict and the start of the Arab uprisings in 2011 (Owens, 2012). Obama was committed to open diplomacy, which he saw as an adequate response to a world in transition. He initially opposed the war in Iraq, while emphasizing that Afghanistan is a major area in the war on terror and that the US and its allies must redirect their resources there. He argued that Iraq would never be the perfect place and the US did not have the resources to make it perfect (Randall, 2009). Obama considered the Iraq war to be unilateral, preventative and in violation of fundamental principles of international law, as well as reckless, without clear explanation and without international support. On the other hand, he considered the war in Afghanistan legal since it began after the UN approval and was a response to a direct attack on the United States, and it was led by a broad international coalition, primarily within NATO. International co-operation and establishing coalitions have been key factors in Obama's approach to Iran and North Korea, and in addressing international terrorism. Obama felt that if he showed good will and openness to dialogue, other states were more likely to cooperate. He also believed that if the US showed good will to Iran, Iran would change its perception of the US, possibly leading to negotiations and abandonment of its nuclear program (Ondrejcsak, 2009). During his election campaign, Obama promised to withdraw US troops from Iraq, and after taking the office as President, presented a plan to reduce troops and eliminate all combat forces by August 2010. He also announced that the remaining troops would be withdrawn by the end of 2011 (Nelson, 2019). In 2009, he ordered an increase in the number of US troops in Afghanistan, and in 2011 he announced US military support for the Libyan resistance movement. While President Bush was focused on unilateral action, preventative war and promoting democracy, Obama pursued a pragmatic foreign policy. In 2010, he set out his main foreign policy goals, from which it can be seen that he had embraced multilateralism. These goals were: to defeat Al-Qaeda, slow climate change, restore American reputation, especially in the Muslim world, promote democracy and human rights around the world (America's soft power), and restore the US economy as a source of both hard and soft power. Unlike President Bush, Obama knew how to recognize the limits of US military power, and wanted to end the wars in Iraq and Afghanistan while avoiding the possibility of wars breaking out with Iran and North Korea (Owens, 2012).

##### *3.1.1. Foreign policy towards the UN*

Obama believed that the UN was an inevitable, but also an imperfect forum. He announced that the United States has rejoined the world and is ready to reconnect with all member states, and that multilateral action, especially within the UN, will be of paramount importance to US foreign policy during his tenure because global challenges the world faces require action from global institutions (Weiss, 2009).

Given the fact that the U.S. did not dominate the world as before, there was a need to renew US leadership in the UN. It had been argued that the US could not continue to achieve its goals without rebuilding multilateral mechanisms and institutions. Problems such as climate change, migration, terrorism, and the proliferation of weapons of mass destruction are transnational, and addressing them does not require unilateral or bilateral action but a global one, so the UN has important global functions in monitoring international crime, drug and human trafficking statistics, and nuclear energy control. However, the interests of the great powers, especially the United States, but also of smaller and poorer states that protect their sovereignty, create obstacles to UN action (Weiss, 2009).

In 2011, the UN Security Council adopted a resolution approving military intervention in Libya. Obama explained that the goal of the intervention was to save the lives of pro-democracy protesters against Libyan dictator Muammar al-Gaddafi. Two days after the UN approved military intervention, the United States, with the help of NATO, established a no-fly zone and began bombing Gaddafi's forces. Obama had significant and uninterrupted assistance from Western countries in his military campaign. After months of military campaigning, rebel forces seized most of Libyan territory and killed Gaddafi. In doing so, Obama demonstrated U.S. support for the Arab Spring, avoided genocide in Libya, and eliminated it as a potential source of terrorism (Kuperman, 2015). However, it will later be shown that it simultaneously destroyed the stability of that country, resulting in anarchy and chaos that continues to this day.

Although President Bush had secured approval from the UN before intervening in Afghanistan, and after the fall of the Taliban regime the UN had a primary responsibility in establishing an interim government, he believed in a limited role of international institutions that should not jeopardize US goals. However, the UN played a role in post-war Afghanistan as it supported the Bonn peace agreement which established an interim government of Afghanistan and the international security forces under the UN were responsible for overseeing the transition process. But after the end of the military campaign in Afghanistan, Bush turned his attention to Iraq and, despite seeking UN approval before the attack, he did not really believe he needed it. After the UN did not approve of the military action, Bush, with the help of a coalition of the willing, started the war in Iraq. Unlike President Bush, who bypassed the UN and was suspicious of international organizations, especially the UN for its lack of support for the war in Iraq, President Obama secured his approval before the military intervention in Libya and believed in the necessity of multilateral action. especially within the UN, which provides legitimacy and is necessary to address global challenges. Obama wanted to strengthen the UN's global role and emphasized the need to build a new international consensus to address global security issues.

### *3.1.2. Foreign policy towards the NATO*

During Obama's administration, the interests of NATO member states were less compatible than ever before. Eastern European countries wanted NATO to protect them from the Russian threat, the US and the United Kingdom wanted NATO to protect them from international terrorism, and France wanted to increase NATO's leadership role in Europe. Bush thought of NATO as an alliance of democracies that needed enlargement in order to serve American interests. Unlike Bush, Obama dismissed the war on terror as a pervasive paradigm of US foreign policy. While Obama acknowledged the threat of international terrorism, he did not think of the war on terrorism as a purely military challenge, but emphasized the strengthening of moderate forces in Islamic states and the US leadership through multilateral cooperation (Keller, 2009).

Obama believed that the outcome in Afghanistan would affect NATO's status, strategy and credibility, and promised to send additional troops to Afghanistan, announcing that it would rely on allies within NATO. He indicated that he was aware of the fact that NATO should play a leading role in stabilizing Afghanistan, and emphasized the importance of its role in the security and stability of the Euro-Atlantic area. He felt that NATO needed to be reformed in order to reduce its limitations and establish greater flexibility of commanders on the ground and streamline the decision-making process (Keller, 2009). Obama's approach to Russian intervention in Georgia (started in 2008, during Bush's term) was multilateral, requiring a unified NATO response, reducing dependence on Russian oil and gas, encouraging deeper integration of Eastern European countries into the global system, including Russia, and the direct involvement of Russia in nuclear proliferation and arms reduction issues. This approach showed his preference for long-term solutions, rather than rushed reactions (Randall, 2009).

After the 9/11 terrorist attacks, for the first time in history, NATO has invoked Article 5 stating that an attack on any member state will be considered an attack on the entire Alliance, and that the Alliance will defend any of its members. NATO also presented President Bush with a proposal listing possible military functions that he could play in the fight against terrorism in Afghanistan. However, differences among NATO members regarding views on NATO's course of action and its role in security challenges have emerged. Bush was prepared to accept NATO's contribution, but without jeopardizing the ultimate goal of the US, so he eventually declined direct assistance and prepared operations in Afghanistan with the help of several partners. Since NATO was divided over whether it should be involved in Iraq, because some members believed that if there were weapons of mass destruction, they should first be located and approval for the attack should be secured from the UN, a new informal coalition was created (the "coalition of the willing") with the help of which Bush invaded Iraq. Unlike Bush, Obama first secured UN's approval during military intervention in Libya, after which he established a no-fly zone with NATO's assistance and began bombing Gaddafi's forces, with continued and strong support from Western states.

### **3.2. Tendency towards using force**

After two President Bush's mandates in which he was pursuing an expansive foreign policy with the belief that the U.S. should be able to unilaterally use force abroad to defend its own national interests and the interests of its allies, Obama was more committed to home affairs and his foreign policy and security approach was non-interventionist. He argued that military action must be limited to defending American vital interests and must act multilaterally, working with its allies to reduce US obligations abroad, restore America's position in the world, and shift the burden to global allies. The reason for such an approach is the legacy of the wars in Iraq and Afghanistan, which caused high costs and declining support of the American public for such actions. However, this approach did not mean a complete rejection of military action (Krieg, 2016). Since the start of the Arab Spring, Obama has emphasized the fact that authoritarian states cause additional instability by rejecting reforms and denying citizens their freedom. Also, he thought that the biggest cause of instability in the Middle East was not the demand for change, but the rejection of change. For Obama's administration and its predecessors, US security and prosperity go hand in hand with overseas democratization, as it is seen that promoting democracy abroad means strengthening the prosperous, capable and democratic states which will become US allies in stopping conflicts and fighting key global challenges. This approach includes fighting Al-Qaeda, defending US allies and securing energy supplies, and the basis for addressing these challenges may be the democratization of the Middle East and North Africa (Bouchet, 2013).

After the UN Security Council approved Obama's intervention in Libya in 2011 to protect pro-democracy protesters from dictatorial rule, the United States, with the help of NATO, established a no-fly zone and began bombing Gaddafi's forces, with strong support from Western states. After months of military campaigning, rebel forces seized most of Libyan territory and killed the Libyan leader. In doing so, Obama supported the Arab Spring, avoided genocide in Libya, and eliminated it as a potential source of terrorism. Although a moderate coalition government won the first democratic elections, it did not last. Libya did not develop into a democracy, but more into a failed state with brutal human rights violations and providing refuge for members of terrorist groups. In 2014, Libya was engulfed in another civil war, between liberals and Islamists. Because of the intervention, Obama violated the US goal of non-proliferation of nuclear weapons, because when Gaddafi came to power, he stopped a nuclear and chemical program and handed over his arsenal to the United States, and his overthrowing and assassination complicated the US goal of persuading other states to give up their nuclear programs (Kuperman, 2015).

Even though there were reports of the use of chemical weapons in Syria against civilians Obama first decided not to launch airstrikes against the authoritarian regime of Bashar al-Assad. Still, he acknowledged that his administration had misjudged the threat of ISIS in Syria and Iraq. ISIS's continued progress and strong public reaction to videos depicting the murder of two US journalists prompted Obama to take action. In 2014, he began airstrikes on ISIS in Syria. He claimed that he, as President, had the authority to address this threat thanks to the Resolution from 2001 which Congress authorized President Bush's use of the necessary military force against those terrorist organizations that carried out or were involved in the 9/11 attacks, and he viewed ISIS as Al Qaeda's successor (Nelson, 2019).

In 2014, the US Air Force provided indirect air support to combat ISIS in Iraq and Syria, following an approach whereby the US would engage partners and allies and share the strategic and operational costs of the war if US national interests were not directly threatened. US airstrikes on ISIS positions in Iraq in 2014 and 2015 were supplemented by Iran's Islamic Revolutionary Guard on the ground. The US also provided military assistance to its allies in the Middle East, most notably Egypt and Jordan, and during the NATO-led military campaign in Libya, the US provided air support to its allies. Among other things, Obama tacitly approved the training and deployment of Libyan rebel forces in the field to work alongside the coalition's air force. US forces have also trained and equipped Syrian rebel forces to combat the Assad regime since 2012, while in northern Iraq trained Kurdish fighters against ISIS militants. The Obama administration relied on air forces, especially drones (Krieg, 2016).

#### **4. CONCLUSION**

The recent era of American foreign policy is mainly a review of foreign policy programs and initiatives of American presidents, so it can be concluded that the president dominates the foreign policy decision-making process, which is why we can talk about the foreign policy of a particular American president. Looking at President Bush's foreign policy and President Obama's foreign policy, it can be said that Obama made a turn in comparison to Bush because, unlike him, Obama embraced multilateralism and a diplomatic approach to everyone, including American allies and hostile states. Even though Bush secured UN's approval before intervening in Afghanistan, and after the fall of the Taliban regime the UN had a primary responsibility in establishing an interim government, he believed in the limited role of international institutions and did not want to allow them to jeopardize US goals. After the end of the military campaign in Afghanistan, Bush turned his attention to Iraq and, despite seeking for UN's approval before the attack, he did not really believe he needed it. After the UN did not approve the military

action, Bush began a war with Iraq with the help of the coalition of the willing. Unlike Bush's bypassing of the UN, Obama believed in the necessity of multilateral action, especially within the UN, which guarantees legitimacy and is necessary to address global challenges, so he has secured UN's approval before military intervention in Libya. After the 9/11 terrorist attacks, NATO invoked Article 5 and submitted a list of possible military functions it could play in the war on terrorism in Afghanistan. Bush was prepared to accept NATO's indirect contribution and support so it could not jeopardize the ultimate US goals, however, he formed a coalition of few countries and with their help he prepared operations in Afghanistan. Since NATO was divided on whether it should be involved in Iraq, a new coalition of the willing was created to attack Iraq. Unlike Bush, Obama secured UN's approval before the start of the military intervention in Libya, after which he intervened in Libya with the help of NATO and a strong support from western countries. In the election campaign, Obama's foreign policy approach seemed less interventionist than Bush's. However, his decision on the US intervention in Libya in 2011 with the help of NATO has shown that Obama is also prone to using military force. Obama initially opposed the Iraq war because he considered that Bush's administration used military force unilaterally without the prior approval of multilateral organizations, while considering the war in Afghanistan legal and legitimate because it had a clear aim, justification and approval from international organizations. Obama's belief in the need for multilateral action is demonstrated by the fact that he sought UN's approval before intervening in Libya. Also, the intervention was carried out with NATO's assistance and a continued support from Western states. Since 2014, the US Air Force has provided indirect air support in the fight against ISIS in Iraq and Syria. US forces have also trained and equipped Syrian rebel forces to combat the Assad regime since 2012, and have trained Kurdish fighters against ISIS militants in northern Iraq. These facts show that Obama was not less inclined to use military force, but, unlike Bush, emphasized the need for prior international approval and multilateral action.

## LITERATURE:

1. Bouchet, Nicolas (2013) The democracy tradition in US foreign policy and the Obama presidency. *International Affairs*, 89(1): 31-51.
2. Drezner, Daniel W. (2013) Rebooting Republican Foreign Policy: Needed: Less Fox, More Foxes. *Foreign Affairs*, 92(1): 143-152.
3. Dumbrell, John (2002) Unilateralism and „America first“? President George W. Bush's Foreign Policy. *The Political Quarterly*, 73(3): 279-287.
4. Gordon, Philip H. (2006) The End of the Bush Revolution. *Foreign Affairs*, 85(4): 75-86.
5. Gregg II, Gary L. (2019) George W. Bush: Foreign Affairs. *Millercenter.org*. <https://millercenter.org/president/gwbush/foreign-affairs> (accessed on July 2nd, 2019)
6. Hoehn, Andrew R.; Harting Sarah (2010) *Risking NATO – Testing the Limits of the Alliance in Afghanistan*. SAD: Rand Corporation.
7. Hurrell, Andrew (2002) „There are no Rules“ (George W. Bush): International Order After September 11. *International Relations*, 16(2): 185-204.
8. Keller, Patrick (2009) Revitalizing NATO: Obama's Neglected Challenge? *American Foreign Policy Interests*, 31(2): 104-114.
9. Krieg, Andreas (2016) Externalizing the burden of war: the Obama Doctrine and US foreign policy in the Middle East. *International Affairs*, 92(1): 97-113.
10. Kuperman, Alan J. (2015) Obama's Libya Debacle: How a Well-Meaning Intervention Ended in Failure. *Foreign Affairs*, 94(2): 66-77.
11. Lindsay, James M. (2011) George W. Bush, Barack Obama and the future of US global leadership. *International Affairs*, 87(4): 765-779.
12. Nelson, Michael (2019) Barack Obama: Foreign Affairs. *Millercenter.org*. <https://millercenter.org/president/obama/foreign-affairs> (accessed on July 3rd, 2019)

13. Ondrejcsak, Robert (2009) American Foreign and Security Policy under Barack Obama: change and continuity. *Cenaa.org*. <http://www.cenaa.org/analysis/american-foreign-and-security-policy-under-barack-obama-change-and-continuity/> (accessed on June 14th, 2019.)
14. Owens, Erik (2012) Searching for an Obama Doctrine: Christian Realism and the Idealist/Realist Tension in Obama's Foreign Policy. *Journal of the Society of Christian Ethics*, 32(2): 93-111.
15. Peterson, John (2002) Europe, America and 11 September. Irish Studies in *International Affairs*, 13(?): 1-20.
16. Randall, Stephen J. (2009) The American Foreign Policy Transition: Barack Obama in Power. *Journal of Military and Strategic Studies*, 11(1/2): 1-24.
17. Visković, Ivo (2007) *Između zavere i diplomatskog haosa – kako se stvara spoljna politika SAD-a*. Beograd: Fakultet političkih nauka.
18. Vukadinović, Radovan (1971) Vanjsko političke dileme suvremene Amerike. *Politička misao: časopis za politologiju*, 8(4): 421-429.
19. Weiss, Thomas G. (2009) Toward a Third Generation of International Institutions: Obama's UN Policy, *The Washington Quarterly*, 32(3): 141-162.
20. Woodward, Bob (2002) *Bush at war*. New York: Simon & Schuster.
21. Young, Terry; Crawford, Peggy (2004) Hands Across The Atlantic? *International Business & Economics Research Journal*, 3(1): 89-96.

## FARMING ECONOMY IN FUNCTION OF THE LAND AREA: THE CASE OF DOURO WINEGROWING SYSTEMS

**Ana Marta-Costa**

*University of Trás-os-Montes e Alto Douro, Centre for Transdisciplinary Development  
Studies, Pólo II - ECHS, Quinta de Prados; 5000-801 Vila Real, Portugal  
amarta@utad.pt*

### **ABSTRACT**

*Companies use a set of production factors that they combine and transform into a final product. This process gives rise to a set of costs and revenues, respectively, which are at the root of the farms' profitability. Several factors influence and conditionate the quantities and types of the used production factors. The area of the land cultivated is an important factor that has been highlighted in the literature. This work aims to analyse the productive systems that characterise grape production in the Portuguese Douro region, at the level of their inputs and outputs and associated economic values, as well as to identify whether the dimensions of production units influence the obtained values. To achieve this purpose, a face-to-face survey was used to collect specific input-output information from a sample of 110 wine-growing farms. The findings show that the quantities of production factors and corresponding costs as well as its yields change according to the size of the farm. In general, farms with an average size of 10 to 20 hectares of vineyard area stand out as those which present a better balance between the yields and costs, and better compensate the remuneration of the entrepreneurial factor and the capital involved in the company.*

**Keywords:** *Inputs, production system, profitability, outputs, winegrowing system*

### **1. INTRODUCTION**

Production units use a set of production factors to obtain their final product, which vary as a whole depending on the final output quantities. However, the used production systems may enhance the combined use of factors and the economy of others, allowing more profitable situations, with reflexes on environmental externalities. In this context, and in the agricultural sector, the used area of production conditionates the used production system and may influence the economic performance, which can be a competitive advantage. This is a subject that has appeared in literature with some controversy, namely in the works of Delord et al. (2015), Diewert and Fox (2010), Galindro et al. (2018), Gleyses (2007), Hooper et al. (2002), Sellers and Alampì-Sottini (2016), Sheng et al. (2015) and Townsend et al. (1998).

Smaller farms use smaller quantities of inputs as a whole, but per unit of area (conventionally the hectare) there may be an excessive use of inputs in order to improve the system, which may be greater than the system's capacity and reduce its profitability. However, it is also in the smallest farms that the use of own resources, such as labour of family origin, can give rise to conditions conducive to its profitability. There are about 570 million farms in the world, most of them smallholdings or family-operated with less than two hectares (Lowder et al., 2014), which makes it relevant to assess whether the management of the system practiced is correctly developed. Sellers and Alampì-Sottini (2016) analysed the influence of firm size on the economic performance of Italian wineries, and their results showed that the size of the firm is positively correlated with all indicators of performance. They found that the company may achieve the optimum size and higher efficiency with increasing returns to scale when the unitary costs are minimized, which confirms the previously results obtained by Diewert and Fox (2010) and Sheng et al. (2015).



Hooper et al. (2002) attribute a fundamental role in this context to the technological progress and access to improvements can also explain why big farms have more productivity. They often have more capital available and easier access to finance than small farms to invest in new technologies that allow reaching higher productivity levels. Nevertheless, the positive relationship between the size and performance or productivity of a company is not always confirmed. Berry and Cline (1979) detected an inverse correlation between farm size and productivity, mainly concerning developing countries. Such situations are also identified in Portuguese viticulture from Douro, declared the oldest demarcated and regulated region in the world, whose production systems have been adapted to the mountainous terrain that hinder productive activity, but allow the production of an excellent quality product - Port wine - known worldwide. Galindro et al. (2018) reveal that medium-sized farmers' vineyards display higher marginal increment for a subregion from Douro and, more recently, Santos et al. (2020) found that the efficiency scores increases with farmers' vineyards size up to 10 to 20 and farmers' vineyards with more than 20 hectares appear to be the least efficient. The aim of this work is to know the viticultural production system used in the Douro region, namely its production factors, products obtained, yields and costs structure, and to analyse the existing relationships according to the obtained production area. The knowledge of the economic impacts of the options taken by the managers of the agricultural production units, may contribute to identify their main potentialities and weaknesses, in order to better adjust them to the used production area.

## 2. METHODOLOGY

### 2.1. Used Model

In this paper we start from the definitions of costs, income and results adopted for the agricultural farms by Avillez et al. (2004). Costs represent the consumption of production factors and income are the benefits obtained directly by the farming system and indirectly by the monetary aid received annually in the form of subsidies. The results are the difference between the incomes and some categories of costs and three types were considered in this work, which represent, respectively, the entrepreneur factor remuneration (Equation 1), the labour factor remuneration (Equation 2) and the capital factor remuneration (Equation 3).

$$\text{Entrepreneur and family income (EFI)} = \text{Gross Production} - \text{Real charges} + \text{subsidies to current activity} \quad (1)$$

$$\text{Labour income (LI)} = \text{Gross Production} - \text{Purchase of goods and services abroad} - \text{Taxes and insurance on land and non land assets} - \text{Depreciation} - \text{Allocated interest} + \text{subsidies to current activity} \quad (2)$$

$$\text{Company's capital income (CCI)} = \text{Gross Production} - \text{Purchase of goods and services abroad} - \text{Taxes and insurance on land and non land assets} - \text{Depreciation} - \text{Rents} - \text{Wages and social charges paid and allocated} + \text{subsidies to current activity} \quad (3)$$

### 2.2. Data

The data used for this work was gathered from a sample of 110 Douro grape producers by a structured face-to-face survey (Table 1). The main criteria for selecting the universe surveyed were the geographical distribution and the size of the farm, which is relevant to the subject under study, in order to ensure the diversity and heterogeneity of production systems present in the farms of Douro. The sample consisted of 31, 32, 30 and 17 farms, belonging respectively to area classes one to five, five to ten, ten to twenty and more hectares, distributed proportionately among the three sub-regions of the Douro. The selected farms with an area equal to or greater than 20 ha were fewer in number due to their lower representation in the Douro region.

The farms of the study were generally contacted in advance by their farmers' associations or cooperative wineries. The data were collected through face-to-face surveys of winegrowers and/or entrepreneurs on the farms, on the farms themselves or on the facilities of their farmers' associations and wineries cooperatives. The agricultural season of inquiry was 2017. The gathered data was then validated by a formal meeting with the respondents and their representative associations through the use of the World Café model realized at 2019.

### 3. RESULTS

Figure 1 illustrates the representative winegrowing production system of the Douro region. Table 1 shows the results obtained by category of costs, yields and their respective results by groups composed by similar sized farms. The ranges of used area correspond to those used for the collection of information and are coincident with those observed in various statistical sources in the sector.

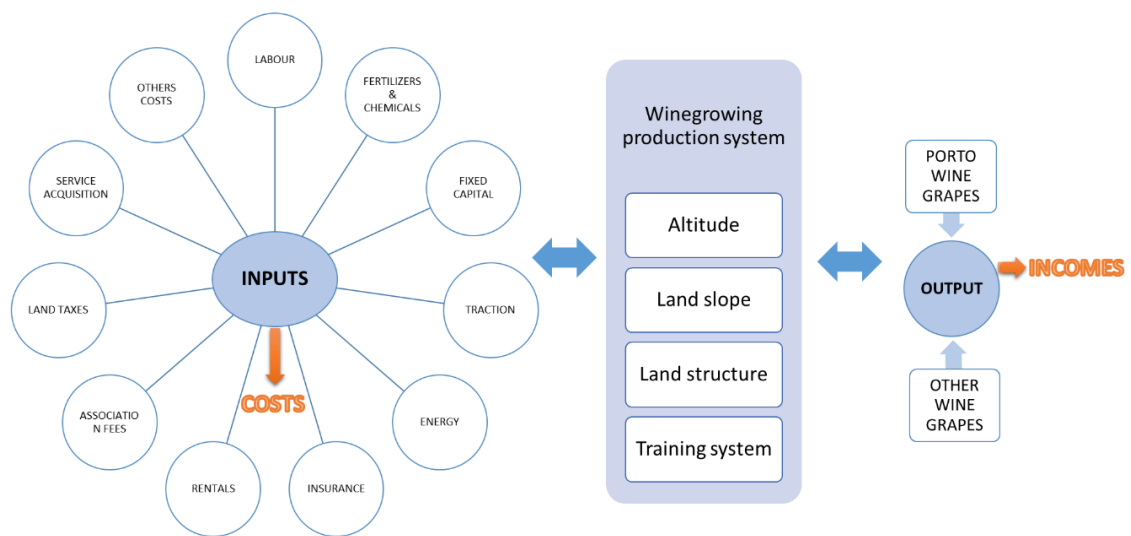

*Figure 1: Winegrowing production system  
(Source: Own elaboration)*

The observation of the exposed elements makes it possible to identify labour as one of the most important production factors in Douro winegrowing systems, whose costs, including social charges, reach, in larger farms, almost 70% of their total real costs. Smaller farms, despite having less spending on labour due to the use of family labour, when quantifying the corresponding opportunity cost, reach values of total cost very close to those evidenced in larger production units. The costs of fertilisers and other chemical products as well as depreciation and amortisation are lower on larger farms as the total value is diluted by a larger number of hectares. In general, the costs with the remaining factors shown in Table 1, as well as the total volume of costs, including or not the attributed costs, are lower for the area size between 10 and 20 hectares. In terms of income, although farms of up to 5 hectares have the highest volume of production and the highest volume of subsidies, they also have the highest expenditure, so they do not stand out as the most profitable farms. Farms with an average size of between 10 and 20 hectares have a volume of production just behind smaller farms. The fact that a large part of their volume is intended for the production of port wine and, therefore, more highly valued on the market allows them to stand out as those with the highest total economic yield obtained per unit area.

Farms area (ha)	[1, 5[	[5, 10[	[10, 20[	[20, ∞[
<b>Costs</b>				
Labour costs purchased and social costs (€/ha)	1177,4	1559,3	1849,4	2403,2
Total labour costs (€/ha)	2358,4	2197,7	2079,7	2403,2
Costs with fertilizers and chemical products (€/ha)	614,4	493,7	486,3	351,8
Costs with energy (€/ha)	27,3	39,7	24,2	67
Amortization/Depreciation costs (€/ha)	805,6	699,1	527,8	434,9
Insurance, rentals, associations fees, land taxes (€/ha)	199,5	171,9	121,3	161,6
Real total costs (€/ha)	3707,5	3389,4	3189,3	3635,4
Total costs (€/ha)	5317,7	4680,3	3864	4074,4
<b>Incomes</b>				
Grapes production in volume (kg/ha)	6050,9	5772	5861,1	5182,4
Grapes production for Port wine (kg/ha)	2005,3	2271,9	2734,2	2620
Grapes production in value (€/ha)	4409,1	4081,1	4593,6	4094,7
Annual subsidies (€/ha)	687,8	498,5	252,8	207,7
Total benefits (€/ha)	5096,9	4579,6	4846,4	4302,4
<b>Results</b>				
EFI - Entrepreneur and family income (€/ha)	1389,4	1109,1	1656,9	667,1
LI - Labour income (€/ha)	712,6	1214	2420,9	2460,6
CCI - Company's capital income (€/ha)	957,9	1182,2	2095,7	1200,3

Table 1: Costs, incomes and economic results with Winegrowing production system of Douro (Source: Own elaboration)

The economic results reflect the observations made previously, highlighting once more the farms with an average size between 10 and 20 hectares at the level of remuneration of the entrepreneur (EFI) and the capital (CCI) factors. These results are in line with those obtained by Berry and Cline (1979), Galindro et al. (2018) and Santos et al. (2020). Large farms above 20 hectares, despite being the group with the highest burden by labour factor, are also the ones standing out the most in terms of remuneration for this factor of production (CCI), regardless of the type of work and its form of remuneration. These situations confirm the analysis from Diewert and Fox (2010), Sellers and Alampì-Sottini (2016) and Sheng et al. (2015).

#### 4. CONCLUSION

This work has made possible to identify the set of production factors that intervene directly in the Douro winegrowing system and enable the gathering of excellent quality grapes, which are responsible for making wines worldwide recognised. In terms of production costs, labour, depreciation of fixed capital and fertilisers and chemical products stand out in order of importance, as the main contributors to the high volume of costs achieved in the region. Being a mountain wine-growing region, the need for this production factor is very high, with a strong weight in the production cost structure, namely in farms without the use of family labour. In general, farms with a vineyard area of 10 to 20 hectares have the most beneficial indicators for the economy of the farm. This is due to the lower volume and value of costs, but also due to the better economic returns provided, in particular, by the higher selling price of grapes intended for Port wine. In conclusion, the production system used in this area dimension (10 to 20 hectares) provides better economic results and, when not depending on structural factors, can be an example to be reproduced in other dimensions.

**ACKNOWLEDGEMENT:** *This work was supported by the R&D Project INNOVINE & WINE – Vineyard and Wine Innovation Platform - Operation NORTE -01-0145-FEDER-000038, co-funded by the European and Structural Investment Funds (FEDER) and by Norte 2020 (Programa Operacional Regional do Norte 2014/2020) and by national funds, through the FCT – Portuguese Foundation for Science and Technology under the project UIDB/04011/2020*

#### LITERATURE:

1. Avillez, F., Jorge, M.N., Serrano, P., Pereira, N., Ribeiro, I. and Trindade, C.P. (2004). Rendimento e Competitividade Agrícolas em Portugal. Evolução recente, situação actual e perspectivas futuras. Almedina Ed.
2. Berry, R.A. and Cline, W.R. (1979). Agrarian Structure and Productivity in Developing Countries. *Ann. Phys.* 24, 118–173. [http://dx.doi.org/10.1016/0003-4916\(63\)90068-X](http://dx.doi.org/10.1016/0003-4916(63)90068-X).
3. Delord, B., Montaigne, E., and Coelho, A. (2015). Vine planting rights, farm size and economic performance: Do economies of scale matter in the French viticulture sector? *Wine Econ Policy*, Vol. 4, n. 1, pp. 22-34. <http://dx.doi.org/10.1016/j.wep.2015.03.001>.
4. Diewert, W. and Fox, K. (2010). Malmquist and törnqvist productivity indexes: returns to scale and technical progress with imperfect competition. *J. Econ.* 101 (1), 73–95. <http://dx.doi.org/10.1007/s00712-010-0137-0>.
5. Galindro, A., Santos, M., Santos, C., Marta-Costa, A., Matias, J. and Cerveira, A. (2018). Wine productivity per farm size: a maximum entropy application. *Wine Economics and Policy*, 7 (1), 77-84. <https://doi.org/10.1016/j.wep.2018.03.001>
6. Gleyses, G. (2007). Rendement d'échelle et économies d'échelle en agriculture. In: T. editor (Ed.), Cemagref, Action 4, UMR G-Eau, Montpellier, p. 29, politiques publiques, aversion au risque des agriculteurs et demande en eau d'irrigation.
7. Hooper, S., Martin, P. and Fisher, G.L. (2002). Farm size and productivity: where are the trends taking us? *Aust. Commod.* 9 (3), 495–500.
8. Lowder, S.K., Skoet, J. and Singh, S. (2014). What do we really know about the number and distribution of farms and family farms worldwide? Background paper for The State of Food and Agriculture 2014. ESA Working Paper No. 14-02. Rome, FAO.
9. Santos, M., Rodríguez, X.A. and Marta-Costa, A. (2020). Efficiency Analysis of Viticulture Systems in the Portuguese Douro Region. *International Journal of Wine Business Research*. <http://dx.doi.org/10.1108/IJWBR-10-2019-0052>.
10. Sellers, R. and Alampi-Sottini, V. (2016). The influence of size on winery performance: evidence from Italy. *Wine Econ. Policy* 5 (1), 33–41. <http://dx.doi.org/10.1016/j.wep.2016.03.001>.
11. Sheng, Y., Zhao, S., Nossal, K., Zhang, D. (2015). Productivity and farm size in Australian agriculture: reinvestigating the returns to scale. *Aust. J. Agric. Resour. Econ.* 59(1), 16–38. <http://dx.doi.org/10.1111/1467-8489.12063>.
12. Townsend, R., Kirsten, J., Vink, N. (1998). Farm size, productivity and returns to scale in agriculture revisited: a case study of wine producers in South Africa. *Agric. Econ.* 19(1–2), 175–180.

## A DEEPER INSIGHT INTO POLITICAL BRAND TRUST – HOW TRUST IN PARTY'S LEADER AND PARTY'S PROGRAM INFLUENCES VOTING STABILITY?

**Ana Pap**

*Faculty of Economics in Osijek, Trg Ljudevita Gaja 7, 31 000 Osijek, Croatia  
anapap@efos.hr*

### **ABSTRACT**

*In recent times, political behavior has become unstable, which led to the fact that analyzing voter choice and behavior has become inevitable for a better understanding of voters. Many researchers have accepted political parties and politicians as brands and political branding has been described as a new area of research. Many studies in the field of political marketing proved that political brand trust positively influences voters' loyalty and their voting stability. This study is trying to get deeper insights into political brand trust by analyzing political brand trust from two aspects: trust in the political party's leader and trust in the political party's program. The purpose of this research is to determine the differences in the influence of trust in the political party's leader and trust in the political party's program on voting stability. In other words, this research is trying to answer the question: What drives voting stability more – trust in the political party's leader or trust in the political party's program? The primary research was conducted in five counties from Eastern Croatia using a highly structured questionnaire. For the purposes of obtaining survey results, regression analysis was performed with the Statistical Package for Social Sciences (SPSS) 21.0. The study results confirmed the positive influence of both trust in the political party's leader and the political party's program on voting stability. Results have shown that trust in political party's leader(s) had a much stronger influence on voting stability than trust in the political party's program. The study has resulted in practical implications for political party marketing managers.*

**Keywords:** *political brand trust, voting stability, political party leader, political party program*

### **1. INTRODUCTION**

One of the most important topics in political marketing research is focused on understanding how voters make their voting decisions and what influences them. The choice of a specific political party is an important decision that a citizen faces in a democratic country. Considering the fact that voters can elect, but not affect policies, the only means at their disposal is to elect the political party (or a politician) that will most likely satisfy their needs and wants (Padovano, 2013). Accordingly, political parties are continuously interested in gaining knowledge about the factors that influence voters' decisions. As political behavior has become unstable and fluctuating for political parties, analyzing voter choice and behavior is becoming inevitable for their better understanding. Voters choose political parties the same way as consumers make their choices about the brand (Reeves et al., 2006). Voters are special kinds of consumers, and there is a resemblance between voting behavior and consumer behavior. Drawing a parallel with commercial marketing – an election can be seen as the moment of sale: the point of choice, where voters employ the knowledge they have about a political party or a candidate and make their choice (Needham, 2005). In this exchange system, trust plays a significant role (Aaker, 1991; Gundlach and Murphy, 1993; Keller, 1993; Ahmed et al., 2011; Banerjee and Chaudhuri, 2016). There is also a well-established fact that there is a positive relationship between political trust and voter turnout (Shaffer 1981, and Hetherington, 1999) and a positive relationship between trust and voter stability (Banerjee and Chaudhuri, 2016). This study is trying to get deeper insights into political brand trust by analyzing political brand trust from two aspects: trust in the political party's leader and trust in the political party's program.

The purpose of this research is to determine the differences in the influence of trust in the political party's leader and trust in the political party's program on voting stability. In other words, this research is trying to answer the question: What drives voting stability stronger – trust in the political party's leader or trust in the political party's program?

## **2. LITERATURE REVIEW**

A brand is defined as “A name, term, sign, symbol, or design, or a combination of them which is intended to identify the goods or services of one seller or a group of sellers and to differentiate them from those of competitors” (AMA, 1960). It is clear that political parties satisfy this definition and that they can be seen as a political brand. In recent times, many researchers have accepted political parties and politicians as brands and political branding has been described as a new area of research (Kotler and Kotler, 1999; Baines et al., 1999; Needham, 2005; French and Smith, 2010; Chou, 2014; Rachmat, 2014, Lees-Marshment, 2015). A political brand is defined as an associative network of interconnected political information and attitudes (Smith, 2005), and both political parties and politicians are viewed as brands (Smith, 2001).

O’Shaughnessy and Henneberg (2007) state that political brands have three clearly distinct elements: a trinity with the party as the brand, the politician as its tangible characteristics, and policy as core service offerings. However, because political brands operate in consumers' minds like other brands, not all associations will have equal importance. Keller (1993) argues that brand associations vary in their relative strength, favourability and uniqueness. This means that the more positive (or negative) these associations are, a political brand will be stronger (or weaker) in a voter's mind. Smith and French (2009) explain that the three key sources of associations of the overall political brand are highly interrelated in the minds of voters. Their relative importance in terms of the overall brand will vary depending on the competitive nature of the political market (i.e., the presence of differentiated or valence policies); the credibility, attractiveness and personality of its leaders; and the party’s perceived salience and credibility in fulfilling its promises.

Trust is a key to build a relationship with others (Kimpakorn and Tocquer, 2009) and it has been proved to be the primary binding force in strengthening the relationship between the political leaders and the voters. The fundamental objective of marketing is to develop an intense bond between the brand and its consumer, and trust plays the most significant role in building this bond (Hiscock, 2001). Trust occurs when one party has confidence in an exchange partner's reliability and integrity (Morgan and Hunt, 1994). Trust has played a significant role in ensuring confidence and managing relationship by lowering the perception of uncertainty and risk in purchasing behavior (Elliot and Yannopoulou, 2007). Brand trust is the confident expectations of brand’s reliability and intentions (of the party) in a risk situation for the consumer (Delgado-Ballester, 2004). Political brands communicate expectations and propositions attached to them to create influence on the thought process of voters. Accordingly, image of the political party and trust in it become the strongest determinant of a consumer's expectation (Banerjee and Chaudhuri, 2016). Burton and Netemeyer (1992) identified that the stability of preferences for a candidate during an election is important. Nevertheless, the same authors also argue that the stability of voting behavior from one election to the next or over many elections is just as important. The stability of voter behavior is a primary concern for political parties. In this paper, the term voting stability refers to the extent that a voter consistently votes for the same candidate or party overtime. This behavior may be because of firmly held preferences or as a means of reducing decision-making effort. Understanding what marketing strategies are likely to shift swing voters (late deciders or non-loyal) is a primary concern in many election campaigns, and previous voter research has shown different effects on stability depending on the level of voter

involvement. Burton and Netemeyer (1992) examined the effects of situational and enduring involvement on voters' response involvement and preference stability. This research has shown some support for the view that stability of preference and involvement are related. Beatty et al. (1988) have argued that involvement with a purchase leads to commitment or brand loyalty in which brand choice is stable over time and situations.

In more recent studies, O' Cass (2005) proved that voter decision involvement, positive affect and voter satisfaction have a significant positive influence on voting stability. Also, O' Cass and Pecotich (2005), in their research, identified opinion leadership as one of the significant antecedents of voting stability. Previous literature lacks research that examines the connection between political party trust and voting stability, especially examining political brand trust separately as a trust in political leaders and political programs. This study is trying to fill this gap by testing separate influences of trust in political leaders and trust in a political program of a certain party on voting stability.

### 3. RESEARCH METHODOLOGY

The research was conducted in five Croatian counties using an in-person survey method. Interviewers have administered paper questionnaires to participants over 18 years of age who are eligible to vote. Interviewers were instructed to choose one male and one female respondent from different age groups (18-31 years, 32-45 years, 46-59 years, and over 60 years old). The research was conducted in the year 2017, and 681 questionnaires were obtained. After preliminary analysis, 19 questionnaires were eliminated due to a large number of missing values, and 662 questionnaires were analyzed. The data analysis was performed with the statistical program SPSS 21.0.

As a research instrument, a structured questionnaire was formulated based on previous research in this area. A total of 3 scales were used in the study. *Voting stability* was adapted from the research of O' Cass and Pecotich (2005), while *Trust in people* and *Trust in the political party* were developed by the author.

*Voting stability* construct consisted of three statements: 1. *I am loyal to one political party.* 2. *I strongly prefer one political party.* 3. *I always vote for the same political party.* *Trust in people* construct consisted of three statements: 1. *Most of the things that leaders of the party I support say about it, is true.* 2. *I trust the leaders of the party I support* 3. *I think that the leaders of the party I support are capable of achieving their goals.* *Trust in the program* construct also consisted of three statements: 1. *I think that the political program of the party I vote for is of quality.* 2. *I believe that the political program of the party I vote for can significantly contribute to the country's development.* 3. *I think that the political program of the party I vote for is feasible.* Respondents were asked to evaluate their level of agreement or disagreement for each statement on the scale from 1 to 5 (1 – I completely do not agree; ... 5 – I completely agree).

As it is shown in Table 1, all proposed constructs have adequate construct reliability (Cronbach's Alpha coefficients above 0.7).

*Table following on the next page*

<i>Measurement scale</i>	<i>Number of items</i>	<i>Mean</i>	<i>Cronbach's Alpha</i>
Trust in people	3	2,856	0,886
Trust in the political program	3	3,341	0,925
Voting stability	3	2,645	0,945

*Table 1. Construct reliability  
(Source: Authors' work)*

## 4. RESEARCH RESULTS

### 4.1. Sample description

The socio-demographic characteristics of the sample consisting of a total of 662 respondents are shown in Table 2.

	<b>n</b>	<b>%</b>
<b>Gender</b>	<b>658</b>	<b>100</b>
Men	328	49,7
Women	331	50,3
<b>Age</b>	<b>657</b>	<b>100</b>
18-31	170	25,9
32-45	169	25,7
46-59	163	24,8
60+	155	23,6
<b>Level of education</b>	<b>658</b>	<b>100</b>
Elementary school	62	9,4
High school	372	56,5
Higher education	224	17,7
<b>Employment status</b>	<b>662</b>	<b>100</b>
Student	110	16,6
Unemployed	64	9,7
Employed	320	48,3
Retired	168	25,4
<b>Income</b>	<b>650</b>	<b>100</b>
Up to 400 €	67	10,3
401 – 800 €	192	29,5
801 – 1200 €	173	26,6
1201 – 1600 €	129	19,8
1601 – 2000 €	51	7,8
More than 2000 €	38	5,8

*Table 2. Socio-demographic characteristics of the sample  
(Source: Author's work)*



## 4.2. Regression analysis

The aim of this paper was to determine what influences more on voting stability – trust in people or trust in the program. Linear regression was performed to test the potential influence. The results of the test are depicted in Tables 3 and 4.

Model	R	r <sup>2</sup>	Adjusted r <sup>2</sup>	Std. Error of the estimate	Change Statistics				
					R square change	F change	Df1	Df2	Sig. F Change
1	.564 <sup>a</sup>	.318	.316	1,27357	.318	153,440	2	659	.000

a. Predictors: (Constant), trust in people, trust in the program

b. Dependent Variable: Voting stability

*Table 3. Model summary  
(Source: Authors' work)*

The proportion of explained variance, as measured by R-Squared for the regression, is 31,8%, as depicted in Table 3. This proportion is relatively high, given the fact that only two influential factors were included.

ANOVA results show that the model reaches statistical significance (Sig = 0,000).

Model		Unstandardized coefficients		Standardized coefficients	t	Significance
		B	Std. Error	Beta		
1	(Constant)	.290	.149		1,941	.053
	Trust in people	.484	.068	.371	7,094	.000
	Trust in program	.237	.068	.223	4,277	.000

*Table 4. Regression coefficients  
(Source: Authors' work)*

The results of linear regression analysis (Table 4) show that both trust in people and trust in the program has a significant positive influence on voting stability. However, as can be seen in Table 4., trust in people has a relatively stronger influence ( $\beta=0,371$ ,  $t=7,094$ ) than trust in the program ( $\beta=0,223$ ,  $t=4,277$ ).

## 5. CONCLUSION

This study contributes to the understanding of voter and consumer behavior in general. Political parties need to know how to allocate their resources during campaigns and develop better knowledge about how and why voters make the choices they do. The fundamental aim of this study was to determine which part of political brand trust influences voting stability more. As the results have shown, trust in people (leaders of the party) has a stronger influence on voting stability than trust in a political program of a party.

Previous research (Banerjee and Chaudhuri, 2016) has proven that political campaign plays a significant role in shaping voters' preference for political party and that it also influences brand trust positively. For political marketing professionals, some significant points emerge from the results. First of all, an effective political campaign should aim at building political trust. Secondly, the projection of a leader in political campaigns should be made carefully after assessing the ground realities. Since the research has shown that trust in political leaders influences voting stability, political parties, in order to achieve and contain voters' stability, must invest more in building a great image of the party leader(s). Party leaders should be in highlighted in a campaign and that is why it is necessary for them to be credible, trustworthy and consistent in their political attitudes. This, however, does not mean that party program should be neglected. Party program has a strong influence on voting stability and without a good party program, no party leader will retain voters' to vote for the party continuously. The main limitation of this research is the sample. The research was conducted on the convenience sample in only one region in Croatia, so the results may be treated with caution in terms of the generalizations of the same to other regions and countries because of the influence of cultural, economic, and political differences. Research should be conducted on the national level, and also, it would be interesting to make some international comparisons. Future research should also include a deeper insight into specific characteristics that make political leader(s) trustworthy.

#### LITERATURE:

1. Aaker, D. (1991). *Managing Brand Equity: Capitalizing on the Value of a Brand*. New York, NY: Free Press.
2. Ahmed, M. A., Lodhi, S. A., Shahzad, M. N. (2011). Political Brand: trusting a candidate in the age of mistrust. *Journal of Business and Retail Management Research*, 5(2), pp. 131-141.
3. American Marketing Association (AMA) (1960) *Marketing Definitions: A Glossary of Marketing Terms*. Chicago, IL: American Marketing Association.
4. Baines, P.R., Lewis, B.R., Ingham, B. (1999). Exploring the positioning process in political campaigning. *Journal of Communication Management*, 3(4), pp. 325-336.
5. Banerjee, S., Chaudhuri, B. R. (2016). Factors responsible behind political brand preference: an empirical study on Indian voters. *Marketing Intelligence & Planning*. 34(4), pp. 559-582.
6. Beatty, S., Kahle, L. and Homer, P. (1988). The Involvement-Commitment Model: Theory and Implications. *Journal of Business Research*, 16 (2), 149-167.
7. Chou, H. Y. (2014). Effects of endorser types in political endorsement advertising. *International Journal of Advertising*, 33(2), pp. 391-414.
8. Delgado-Ballester, E. (2004). Applicability of a Brand Trust Scale across Product Categories: A Multi-group Invariance Analysis. *European Journal of Marketing*, 38(5& 6), pp. 573-529.
9. Elliot, R., Yannopoulou, N. (2007). The Nature of Trust in Brands: A Psychosocial Model. *European Journal of Marketing*, 41(9 & 10), pp. 988-998.
10. French, A., Smith, I. G. (2008). *Measuring Political Br& Equity: A Consumer Approach*. Proceedings of the 5th International Conference on Political Marketing, Manchester Business School.
11. Gundlach, G.T. and Murphy, P.E. (1993). Ethical and legal foundations of relational marketing exchanges. *Journal of Marketing*, 57, pp. 35-46.
12. Hetherington, M. (1999). The Effect of Political Trust on the Presidential Vote, 1968-96. *American Political Science Review*, 93(2), pp. 311-326.
13. Hiscock, J. (2001). Most trusted brands. *Journal of Marketing*, pp. 32-33.

14. Keller, K. L. (1993). Conceptualizing, Measuring, and Managing Customer-based Brand Equity. *Journal of Marketing*, 57(1), pp. 1–22.
15. Kimpakorn, N., Tocquer, G. (2009). Employees' commitment to brand in the service sector: Luxury hotel chains in Thailand. *Journal of Brand Management*, 16, pp. 532-544.
16. Kotler, P., Kotler, N. (1999). Generating Effective candidates, Campaigns, & causes. In B. Newman (ed.) *Handbook of Political Marketing*, Sage: Thousand Oaks, CA.
17. Lees-Marshment, J. (2015). *Political marketing: Principles & applications* (2nd ed.). New York: Routledge.
18. Morgan, R.M., Hunt, S.D. (1994). The commitment-trust theory of relationship marketing. *Journal of Marketing*, 58, pp. 20-38.
19. Needham, C. (2005). Brand Leaders: Clinton, Blair and the Limitations of the Permanent Campaign. *Journal of Political Studies*, 53, pp. 343–361.
20. O'Cass, A. (2003). Electoral choice: The effect of voter control and involvement on satisfaction and voting stability. *Journal of Political Marketing*, 3(1), pp. 61-85.
21. O'Cass, A., Pecotich, A. (2005). The dynamics of voter behavior and influence processes in electoral markets: a consumer behavior perspective. *Journal of Business Research*, 58(4), pp. 406-413.
22. O'Shaughnessy, N.J., Henneberg, S.C. (2007). The Selling of the President 2004: A Marketing Perspective. *Journal of Public Affairs*, 7, pp. 249–268.
23. Padovano, F. (2013). Are we witnessing a paradigm shift in the analysis of political competition?. *Public Choice*, 156(3), pp. 631–651.
24. Rachmat, M. (2014). The Impact of Political Brand Trust on Voting Intention: Evidence from 2013 North Maluku Governor Election. *The IUP Journal of Brand Management*, 11(2), pp. 56-70.
25. Reeves, P., de Chernatony, L., Carrigan, M. (2006). Building a political brand: Ideology or voter-driven strategy. *Journal of Brand Management*, 13(6), pp. 418–428.
26. Shaffer, S. (1981). A Multivariate Explanation of Decreasing Turnout in Presidential Elections, 1960-1976. *American Journal of Political Science*, 25(1), pp. 68-95.
27. Smith, G. (2001). The 2001 General Election: Factors Influencing the Brand Image of Political Parties & Their Leaders. *Journal of Marketing Management*, 17(9), pp. 989-1006.
28. Smith, I. G. (2005). Politically Significant Events & Their Effect on the Image of Political Parties: A Conceptual Approach. *Journal of Political Marketing*, 4(2/3), pp. 103–26.
29. Smith, G., French, A. (2009). The political brand: A consumer perspective. *Marketing theory*, 9(2), pp. 209-226.

## **APPROACHES IN MANAGEMENT IN A SELECTED SERVICE SECTOR FOCUSED ON CUSTOMER SATISFACTION**

**Simona Jaculjakova**

*University of Zilina, Slovakia*  
*simona.jaculjakova@fpedas.uniza.sk*

**Dominik Laitkep**

*University of Zilina, Slovakia*  
*dominik.laitkep@fpedas.uniza.sk*

**Peter Jucha**

*University of Zilina, Slovakia*  
*peter.jucha@fpedas.uniza.sk*

### **ABSTRACT**

*Slovak Post is a company with a long tradition, which is also a national postal operator. This organization is a stable company in the postal sector in the Slovak Republic and in order to maintain its monopolistic position, it is necessary to constantly maintain stability in the postal market. The Office for the Regulation of Electronic Communications and Postal Services oversees the maintenance of the stability and quality of the provided postal services, which annually monitors the state of provision of the universal service provided by Slovak Post. In the article, we relied on the results of the primary research, which monitored customer satisfaction with the services of Slovak Post. This primary research was carried out by the University of Žilina for the benefit of the regulatory authority throughout Slovakia in selected towns and villages where it was necessary to focus mainly on small, medium and large branches of the Slovak Post. The aim of the article was to evaluate customer satisfaction with the services of Slovak Post. In the theoretical part of the scientific article we define the postal sector, Slovak Post, universal service in the postal sector as well as the definition of the tasks of the regulatory authority. In the practical part of the scientific article, we focused on the evaluation of primary research and specifically on the extent to which customers are satisfied or dissatisfied with specific services of Slovak Post. The conclusion contains an evaluation of the quality of individual services based on respondents' answers and suggestions for improvement in services with which customers are least satisfied in quality.*

**Keywords:** *Customer, Satisfaction, Service, Slovak Post*

### **1. INTRODUCTION**

The postal sector could be defined as a community which is dedicated to improving the quality of postal services. Subsequently, we could also define the postal sector as a community governed by a regulatory framework and various measures to guarantee the providing of universal service and to setting maximum limits for postal services that EU Member States may reserve for selected universal service providers with a view to guaranteeing and providing universal services. It is also important in this sector to maintain universal service in order to gradually and progressively reduce the timelines for deciding on further market opening by competition in order to create a quality internal market for postal services. Part of the postal sector in the Slovak Republic is also Slovak Post, originally Slovak Post. Since 1993 is Slovak Post the national postal operator in the Slovak Republic. It means it is a leading provider of advanced communication, distribution and payment services in the domestic market. Slovak Post has the establishment of logistical conditions for doing business in Central Eastern Europe as well. The main goal of Slovak Post it is to be a trusted provider of postal services which meet

the changing needs of customers and also offers new products and comprehensive solutions with added value and high quality. Slovak Post has a monopolistic position on the postal market in the Slovak Republic. The national postal operator, which is Slovak Post provides the following services:

1. Provision of universal postal service to the extent defined by a postal license on the basis of a special regulation granted by the Office for the Regulation of Electronic Communications and Postal Services.
2. Provision of postal services.
3. Implementation of postal operations in the Slovak Republic.
4. Rapid courier transport of items.
5. Implementation of the construction, operation and development of a unified postal network in the Slovak Republic.
6. Publishing of professional literature, regulations, information materials, etc.
7. The issue of postage stamps.
8. Management of archiving postage securities, etc.
9. Agenda associated with postage stamps, setting up occasional compartments, etc.
10. Activities of the Postal Museum.

The main activity of Slovak Post is the provision of universal service. By universal service we understand the offer of postal services, according to 324/2011, Coll. Of the Postal Services Law, which defines that the universal service must serve to ensure the minimum satisfaction of the needs of all users of postal services in the Slovak Republic, so as to ensure the availability of public postal network access points, public postal network contact points under the same conditions, of specified quality, at a reasonable price, every working day with at least one pick-up and delivery per day. The universal service provider uses a postal network consisting of postal network units and resources when providing postal services. The basic function of the postal service is the safe delivery of items to the addressees' doors using the shortest and fastest methods. The Office for the Regulation of Electronic Communications and Postal Services grants the right or imposes an obligation to provide universal service and determines the scope and conditions for the provision of universal service such a license granted to Slovak Post. The Office for the Regulation of Electronic Communications and Postal Services is a state regulatory authority which is responsible for regulating the postal services market together with the supervision of this market. From the point of view of the postal sector, the Office for the Regulation of Electronic Communications and Postal Services performs the following activities:

- State regulation of postal services and postal payment system;
- State supervision over the provision of postal services and postal payment system;
- Cooperation with regulatory authorities of other states in the field of postal services;
- The function of a notifying body in the field of state regulation;
- Other activities according to the law;
- Statistical survey for postal services.

## **2. METHODOLOGY**

In implementing the practical part of the scientific article, we focus on selected issues of primary research, which was conducted at the request from the Office for the Regulation of Electronic Communications and Postal Services in order to survey the area of the postal sector. The survey was conducted through survey directly, like reaching and asking customers at branch offices of Slovak post in every part of Slovak Republic. As part of this survey, it was necessary to find out how the universal service is provided for the customers of Slovak Post are satisfied with the provision of this service. As part of the survey, it was necessary to focus on small, medium and

large post offices. Throughout the Slovak Republic, we conducted a survey at 107 branches of the Slovak Post. The condition was to reach at least 10 customers at one branch. Another condition was to address customers who are at least 18 years old. We addressed a total of 1 044 Slovak Post customers who were over 18 years of age in the survey.

### 3. RESULTS

The following section provides answers to selected questions from the primary research, which were focused exclusively on customer satisfaction with specific mail services. Figure 1 shows customer satisfaction with the service of providing information to customers at branches offices of the Slovak Post. These information should be provided by employees of specific post offices.

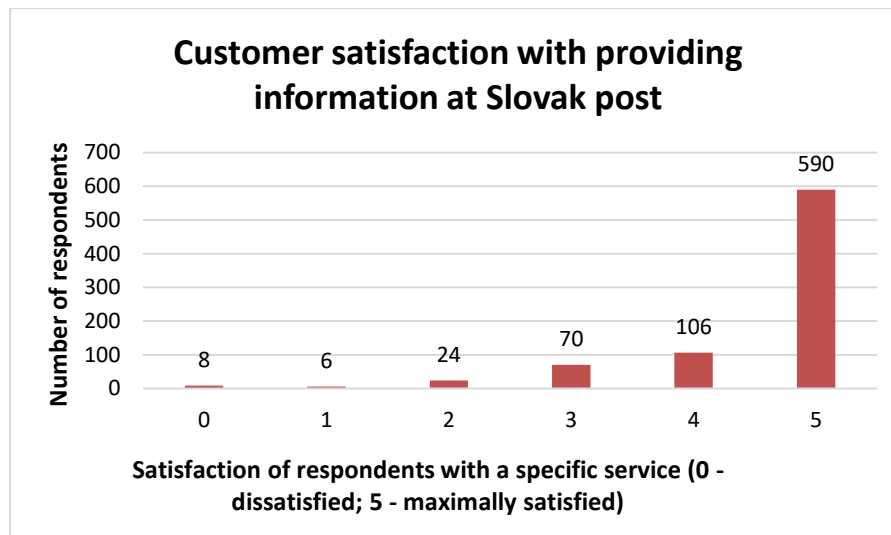

Figure 1: Customersatisfactionwithprovidinginformation at Slovak post  
(Source: Authors)

As you can see, customers are very satisfied with the provision of information at Slovak Post officebranches. Often, as a complementary answer, respondents stated that the staff are very nice and helpful and staff have no problem with advice and help. Only in exceptional cases, customers did complain about the unwillingness of employees to advise in case of problems. Figure 2 shows customer satisfaction with the provision of information on the Slovak Post website.

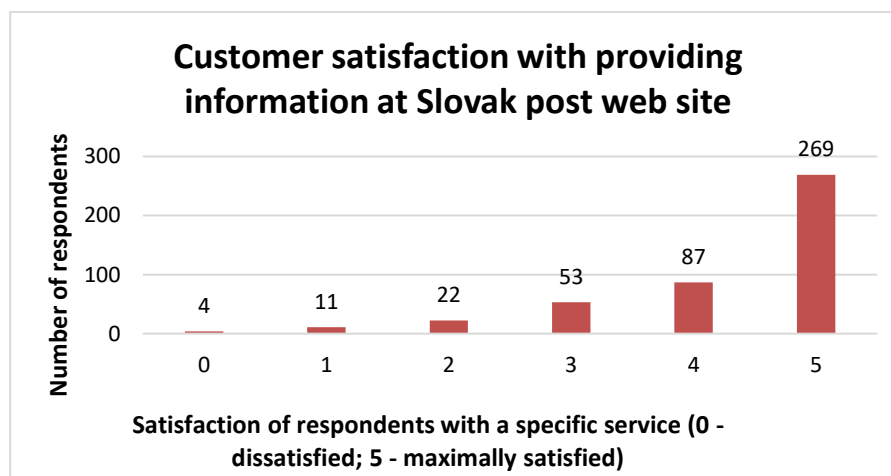

Figure 2: Customersatisfactionwithprovidinginformation at Slovak post web site  
(Source: Authors)

In this case it wasn't that many respondents, because customers do not visit the Slovak Post website frequently. Most of the respondents were older, but there were also younger people among them, who do not need to visit the Slovak Post website. Most of the were satisfied with how they can find the information on the Slovak Post's website.

Next three Figures, Figure 3, Figure 4 and Figure 5 show how satisfied customers are with the services PACKAGES, LETTERS and POSTAL MONEY ORDERS. These are classic services for sending letters, parcels and postal orders. In these figures, respondents stated whether or not they had a problem in using these services, whether they know how to fill requests in the necessary forms and write the address, or whether everything is understandable for a specific service.



Figure 3: Customer satisfaction with use of service PACKAGES  
(Source: Authors)

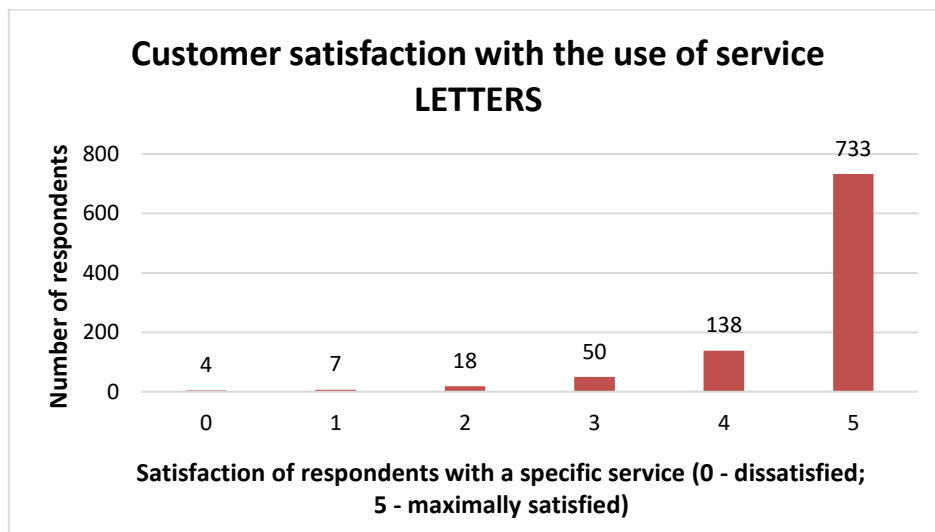

Figure 4: Customer satisfaction with use of service LETTERS  
(Source: Authors)

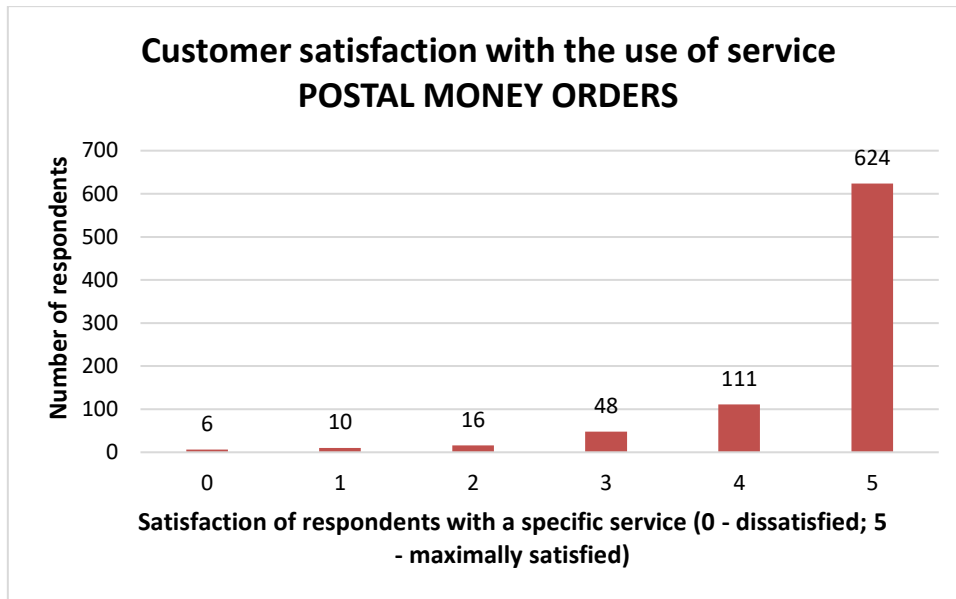

Figure 5: Customersatisfactionwithuse of servicePOSTAL MONEY ORDERS  
(Source: Authors)

Based on the answers, which you can see from Figures 3-5 we can say respondents generally answered that they are satisfied with the use of these three services. The majority stated there is no significant problem with filling in forms or sending shipments. Everything for them was understandable. Several respondents stated that information on what they had to do could be more accurately and better explained. The smallest number of respondents stated that they had problems with specific services and the main problem was that they did not know how to fill in the relevant forms correctly. The following Figure 6 shows customer satisfaction with the service of collection of the notified consignment. These are consignments when the customer receives a notification at home stating that he has a consignment stored at a specific office branch of Slovak Post. The consignee of the consignment must come with such a ticket to a specific office branch of Slovak Post and pick up the consignment.

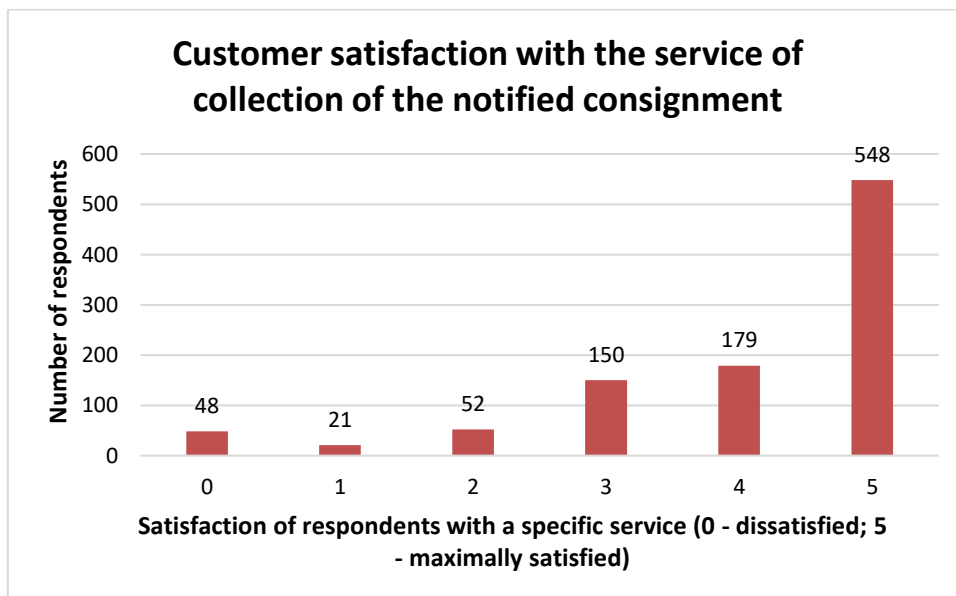

Figure 6: Customersatisfactionwiththeservice of collection of thenotifiedconsignment  
(Source: Authors)



Respondents were also in this case with the implementation of this service satisfied. However, there were also more cases of less satisfied respondents or completely dissatisfied respondents than in previous services. A common problem was that the couriers or postmen did not test whether the customer was at home so that customers could take over the shipment immediately from them, but automatically left a notification in the mailbox about the shipment at the Slovak Post office branch. Figure 7 shows the latest customer satisfaction with the complaint handling service of Slovak Post by customers.



Figure 6: Customersatisfactionwiththecomplainthandlingservice  
(Source: Authors)

Significantly fewer respondents commented on this issue than on the previous ones, due to the fact that very few respondents dealt with complaints at Slovak Post. However, as can be seen, among the respondents who dealt with complaints, the positive attitude to how complaints were handled by Slovak Post employees did not significantly exceed. Dissatisfaction with their handling was almost equal to maximum satisfaction.

#### 4. CONCLUSION

The primary research, which was carried out at the request of the Office for the Regulation of Electronic Communications and Postal Services for the purpose of a statistical survey for the postal sector, showed that Slovak Post's customers are most satisfied with postal services. In most cases, customers had no problem with any services and understood everything perfectly. The biggest problem represented handling of complaints. Slovak Post should focus on this service and try to improve them in the future. The only advantage is that the respondents submitted complaints to the post office in a minimum number, and overall the complaint handling service is the least used. It is also worth mentioning the service of picking up announced shipments, which is slightly worse than other services. In this case, the biggest problem was the behavior of postmen and couriers. The post office should focus on this problem and try to minimize it even more. Despite the fact that the respondents were very satisfied with the postal services, there is still few services for improvement.

**ACKNOWLEDGEMENT:** This paper was supported by project VEGA 1/0755/18 and VEGA 1/0518/19.

## LITERATURE:

1. DIRECTIVE OF THE EUROPEAN PARLIAMENT AND OF THE COUNCIL 2008/6/ES. (2008). Retrieved 15. 05. 2020 from [https://eur-lex.europa.eu/legal-content/SK/TXT/PDF/?uri=CELEX%3A32008L0006&from=EN&fbclid=IwAR3nqUersR8i3iQb7KTVVPTYh4XsPMx\\_lFBBqme5Z0x8gHq-2UncBI8gzGE](https://eur-lex.europa.eu/legal-content/SK/TXT/PDF/?uri=CELEX%3A32008L0006&from=EN&fbclid=IwAR3nqUersR8i3iQb7KTVVPTYh4XsPMx_lFBBqme5Z0x8gHq-2UncBI8gzGE)
2. Profile of Slovak Post. (2020). Retrieved 21. 05. 2020 from <https://www.posta.sk/informacie/profil-spolocnosti>
3. General Post conditions. (2020). Retrieved 23. 05. 2020 from <https://www.posta.sk/subory/36961/postove-podmienky-vseobecna-cast-vnutrostatny-styk.pdf>
4. The Postal license. (2020). Retrieved 27. 05. 2020 from <https://www.teleoff.gov.sk/postova-licencia/>
5. General informations. (2020). Retrieved 01. 06. 2020 from <https://www.teleoff.gov.sk/onas/>
6. Sustainable postal service design: integrating quality function deployment from the customers perspective. (2020). Retrieved 23.05.2020 from <https://link.springer.com/content/pdf/10.1007/s13198-019-00906-6.pdf>  
An integrated approach to analysing the cost efficiency of postal networks. (2020). Retrieved 23.05.2020 from <https://www.sciencedirect.com/science/article/pii/S0957178719303558?via%3Dihub>
7. Stofkova, J., Stricek, I., Stofkova, K.. Data analysis in quality management of the network enterprise
8. Conference: International Conference on Engineering Science and Production Management. ESPM Production management and engineering sciences, pp. 273-278. (2016). Retrieved 21.05.2020

## HOW TO IDENTIFY GROSS R&D POTENTIAL IN INDUSTRY 4.0

**Miroslav Balog**

*Centre of Social and Psychological Sciences, Slovak Academy of Sciences, Slovak Republic  
progmiba@savba.sk*

**Lubica Kotorova Slusna**

*Strategos, s.r.o., Slovak Republic  
lubica.slusna@gmail.com*

### **ABSTRACT**

*The Fourth Industrial Revolution brings numerous technological concepts and innovations that catalyse the industry transformation and increase productivity level. High development dynamics is determined by the undertaken intensive research and development in various technological domains. Important stakeholders in the development of Industry 4.0 are public R&D organisations. They are considered traditional knowledge providers, and their ability to participate in the development of Industry 4.0 depends on a variety of factors, such as human resources, technologies, knowledge networks, etc. In the case of human resources, it is possible to identify the gross potential representing the theoretical capacities of public R&D organisations. The aim of this paper is to present a pilot mapping of the national gross R&D potential, specifically Industry 4.0 in the Slovak Republic. Gross potential is identified via comprehensive mapping of human resources as well as international activities of the public R&D organisations. Defined gross potential represents the base for the identification of public R&D networks related to Industry 4.0.*

**Keywords:** *Gross potential, Research & Development*

### **1. INTRODUCTION**

The current COVID-19 pandemic has shown the vulnerability of the economy, as well as civilisation as a whole, to unforeseen events. Industry is declining due to the quarantine of human resources. The systematic approach of replacing human resources in industry involves the use of state-of-the-art technologies associated with automation and digitisation of production. This is the so-called Fourth Industrial Revolution – also known as Industry 4.0.

The Industry 4.0 label comes from a project originally initiated by the German government to stimulate development and enhance the competitiveness of domestic industry. This strategic initiative is a response to the growth in the quality of main competitors in industrial production. Similar activities were gradually launched by a number of countries, including Slovakia. Currently, the Fourth Industrial Revolution is at the beginning of its longer run to massive industry penetration through advanced technologies. The Fourth Industrial Revolution is built on the mobile and ubiquitous Internet, the application of a number of sensors, artificial intelligence, and machine learning (Schwab, 2016). Industry 4.0 is considered the next stage in the digitisation of the manufacturing sector, driven by factors such as (Lee et al., 2013) a large increase in data, computing power and connectivity, increased analytical capabilities, new forms of human-machine interaction (touch interfaces and augmented reality), but also improvements in transferring digital instructions to the physical world (advanced robotics, 3D printing). Industry 4.0 is a trend towards automation and data exchange in the manufacturing sector, which includes cyber physics systems, the Internet of Things, and cloud computing (Kagermann, 2013). Industry 4.0 is understood as the stage at which integration takes place between manufacturing operating systems and ICT, especially the Internet of Things, thus creating cyber physical systems (Wang, 2015). There is currently an uneven development of

various technologies and an increase in the importance of some technologies, such as cyber security (Lezzi, 2018). The implementation of Industry 4.0 in companies stimulates the development of various technical domains that are interconnected. The dynamics of technologies development depends on the changing needs of industry, which is considered a key determining factor. The implementation of a wide range of technologies is transforming current factories into smart factories. At present, we are on the edge of the phase involving transformation of individual companies and entire industries to a qualitatively new level with higher performance and production quality. Industry 4.0 has the potential to dramatically increase overall industry productivity and value added. Industry 4.0 is transforming automatic production and elevating it to a new level by introducing customised and flexible mass production technologies (Kagermann, 2013). It is possible to assess company readiness on such technological upgrading (Herčko, 2020). The concept of Industry 4.0 is heterogeneous and involves the integration of more than 30 different technological areas that are constantly evolving (Chiarello, 2018), while the usability of individual technological domains is not the same (Delanogare, 2018). In addition, it is possible to integrate Industry 4.0 into business planning, research and development (R&D), asset optimisation and supply chain development, which brings additional business value, delivering strategic and operational benefits (Telukdarie, 2018). Industry 4.0 is thus not a single technology, but a socio-technical concept where technological, social and organisational aspects interact (Beier, 2020). The Industry 4.0 development, as well as implementation, depend on the quality of human resources beyond the R&D (Cagaňová, 2019). Leadership is essential in organisations in order to successfully promote a culture of innovation. As a result, leaders play a key role in changing the paradigm towards Industry 4.0 (Guzmán, 2020). Human resources are also important in the field of R&D. The challenge is to identify the gross R&D potential of human resources at the national level, which can contribute to the Industry 4.0 development. This means that gross potential represents overall theoretical national R&D capacity embedded within public R&D organisations. Such an approach can support smart specialisation in defined technology domains. The primary interest of this paper is to identify this (quantitative) theoretical gross potential in the public R&D organisations that are traditional knowledge providers. On the other hand, it is also important to assess available human resources from a broader qualitative perspective.

## 2. METHODOLOGY

Gross R&D potential was determined by mapping the number of R&D workers at selected public R&D organisations. There are 23 public universities officially registered by the Ministry of Education, Science, Research and Sport of the Slovak Republic. Public universities operating in areas outside the scope of Industry 4.0, such as theology, medicine, or veterinary medicine, were excluded from the study (a total of eight universities). In addition, the Slovak Academy of Sciences was also included in the research, since it represents one of the largest R&D-orientated public organisation in Slovakia. The mapping was carried out by collecting information published on the official websites of all public R&D organisations. The research was focused on determining the number of R&D employees at individual units such as institutes and/or departments relevant to Industry 4.0. The individual departments/institutes were selected according to their names and R&D activities published on the webpages. In principle, two kinds of departments/institutes were identified at 13 universities. There were units directly focused on Industry 4.0 (e.g. robotics, artificial intelligence) as well as organisations indirectly related to Industry 4.0 (e.g. mathematics, energy machines). Moreover, human resources have also been identified in selected areas of the cultural and creative industries, which have the greatest relevance to Industry 4.0 (additional two universities).

The identified human resources were classified into the following groups according to their positions: professor, associated professor, assistant professor/PhD, and PhD students. The other resources, such as external experts and technicians, were also taken into consideration. Information published on the official webpages determined the obtained results. To minimise the effects of inaccurate data, annual reports of the selected public R&D organisations were used as a source of missing data. Therefore, it is expected that discrepancies between the obtained results and the real potential will be limited. The mapping took place during October and November 2019. The identified gross potential of human resources represents the theoretical human resources capacity of public R&D organisations which may be involved in the development of Industry 4.0. In addition, the geographical distribution of human resources was determined according to the location of headquarters at faculty level. The mapping of the gross R&D potential was supplemented by international activities investigated on an individual basis. Participation of public R&D organisations within the European Union Horizon 2020 programme on the topic of Industry 4.0 were investigated in detail. The most efficient organisations in the trans-European Horizon 2020 programme were selected. The identification was carried out using the public database of the Slovak Centre of Scientific and Technical Information. The database included data about project proposals submitted to Horizon 2020, as well as an approved project until December 2019. This database comprised data about 1,166 applications that were prepared by 853 organisations. A total of 303 applications were approved under Horizon 2020. Project proposals and approved projects relevant to Industry 4.0 were selected via keyword identification in each abstract, as well as the title, of the proposals. The following keywords were used: robot, IoT, Internet of Things, industrial Internet, simulation, augmented reality, additive manufacturing, 3D printing, big data, cloud, cyber, cyber security, artificial, artificial intelligence, Industry 4.0. Nevertheless, some of the selected projects were not relevant to Industry 4.0, since another R&D domain contains the same word. Specifically, IoT is included in the word biotechnology. Therefore, all selected proposals and projects were checked individually. Finally, a total of 159 project applications relevant to Industry 4.0 were selected, of which 51 were approved.

### **3. MAIN FINDINGS**

#### **3.1. Gross R&D**

A comprehensive assessment of Slovak public R&D organisations according to their focus/activities showed (theoretical) gross potential for Industry 4.0 development. Organisations dealing with the following topics were taken into considerations as relevant to Industry 4.0:

- Automation, robotics, cybernetics, artificial intelligence
- Informatics, information and communication technologies, informatisation, software engineering, multimedia, telecommunications, geoinformatics, digitisation, digital engineering
- Machine design, mechatronics, applied mechanics, structural mechanics, mechanical engineering, production biosystems, production technologies, progressive technologies, technical systems, production management, industrial engineering, quality engineering, recycling technologies, aerospace engineering, transport, transport technology, transport engineering, ecochemistry, biophysics
- Electrical engineering, applied electrical engineering, power engineering, photonics, nuclear and physical engineering, energy machines, process engineering, electronics, production and process technology
- Mathematics, physics, numerical methods, statistics, geometry, statistics, operations research

This list corresponds to the names of the individual departments and/or institutes located at universities. A detailed web investigations showed that many of those departments are directly focused on various technological domains relevant to Industry 4.0, such as augmented reality, cyber security, additive manufacturing, simulations, big data, etc. However, these technology domains are not included within the official names of selected departments/units. As such, none of the technology domains of Industry 4.0 were excluded from the study. There are 118 departments and/or institutes at the national public universities in Slovakia operating on the topics mentioned above. A total of 310 professors, 506 associate professors and 1,014 assistant professors and researchers (PhD) work at these identified organisations. Within the departments and/or institutes identified, 569 PhD students are preparing for their research careers. In addition to that, there are also 193 external experts and 172 technicians. In total, 2,764 human resource elements relevant (potentially) to Industry 4.0 are available at the selected (13) universities. For comparison, a total of 1,394 professors and 2,480 associate professors, as well as 5,032 assistant professors (PhDs), are operating at all 23 public universities. This means that approximately 22% of professors, 20.4% of associated professors and 20.2% of assistant professors/PhDs operate in departments/institutes potentially relevant to Industry 4.0. Said finding indicates that sufficient gross potential to engage in addressing the challenges associated with the development of Industry 4.0 is available in Slovakia. The most significant gross potential (Tab. 1) was identified at three universities, namely the Slovak University of Technology in Bratislava (STU), the Technical University of Košice (TUKE) and the University of Žilina (UNIZA). The identified potential at other universities and the Slovak Academy of Sciences was significantly lower.

University	Human resources			
	Professors	Associate professors	Assistant professors (PhD)	PhD students
The Slovak University of Technology in Bratislava	105	143	366	175
The University of Žilina	60	84	241	159
The Technical University of Košice	77	126	167	129

*Table 1: The three largest Slovak universities and their gross potential in Industry 4.0  
((Source: own research))*

The greatest gross R&D potential for the development of Industry 4.0 lies at the Slovak University of Technology in Bratislava. A total of 105 professors, 143 associate professors, 366 assistant professors and 175 PhD students operate at the departments and/or institutes relevant to Industry 4.0. At the STU, the potential was identified at the Faculty of Electrical Engineering and Information Technology, the Faculty of Chemical and Food Technology, the Faculty of Informatics and Information Technologies, the Faculty of Materials Science and Technology in Trnava, the Faculty of Mechanical Engineering, and the Faculty of Civil Engineering. The second most important university in terms of the number of researchers potentially utilised for Industry 4.0 is the University of Žilina, with 60 professors, 84 associate professors, 241 assistant professors and researchers, and 159 PhD students. At the University of Žilina, the potential was identified at the Faculty of Electrical Engineering and Information Technology, the Faculty of Management Science and Informatics, the Faculty of Security Engineering, the Faculty of Mechanical Engineering, and the Faculty of Civil Engineering, but also at the Faculty of Operation and Economics of Transport and Communication. The Technical University of Košice is the third most important university in terms of the number of researchers available for Industry 4.0 development. There are 77 professors, 126 associate professors, 167 assistant

professors and researchers, and 129 PhD students in relevant fields. At this university, potential was found at the Faculty of Electrical Engineering and Informatics, the Faculty of Manufacturing Technologies, the Faculty of Materials, Metallurgy and Recycling, the Faculty of Mechanical Engineering, and the Faculty of Civil Engineering, but also partly at the Faculty of Aeronautics. It can be stated that even within the three most important universities there is sufficient potential for the development of selected technological areas of Industry 4.0. Together they have approximately 242 professors, 353 associate professors and 774 assistant professors, as well as 463 PhD students. This means that these 3 universities cover almost 80% of overall human resources relevant to Industry 4.0 available at public universities. The Slovak Academy of Sciences (SAS) is one of the largest public R&D organisations in Slovakia. In the case of the SAS, the following four institutes are dealing with Industry 4.0 issues: the Mathematical Institute SAS, the Institute of Measurement Science SAS, the Institute of Informatics SAS, and the Institute of Materials and Machine Mechanics SAS. The overall capacity of the SAS comprises more than 200 scientists, including professors (14) and associated professors (26). Its potential is catalysed by available PhD students. In addition to these technically-orientated domains, there are also some additional fields relevant to cultural and creative industries with the potential to contribute to the development of Industry 4.0. The following indirectly-relevant fields may be considered as likely to be utilised: visual communication, design, graphics, digital media or media. An additional 8 professors, 13 associate professors, 34 assistant professors and 17 PhD students increase the broader human capacity/potential allocated at two art-orientated universities.

### **3.2. Geographic distribution of human resources**

The Slovak Republic is divided into eight self-governing regions (NUTS 3). The public R&D organisations engaged in the mapping have headquarters located in all of them, but their regional distribution is uneven. There is at least one public university or institute with a potential link to the Industry 4.0 concept located in each region. In terms of the headquarters' location, the most important is the Bratislava self-governing region, where the majority of organisations operate. Concerning the human capacity, the most important region is Bratislava, where the highest number of researchers (1,268) operate, followed by the Žilina region (601) and the Košice region (547). The Prešov region is the smallest from the perspective of human resources located at the university (83). From the detailed perspective, the highest number of professors (131) and associate professors (209) also operate specifically in the Bratislava region, followed by the Košice region (77 professors and 126 associate professors) and the Žilina region (60 professors and 86 associate professors). In other regions, the number of high-quality researchers is significantly lower. The geographical distribution of human resources relevant to Industry 4.0 is in line with the size of the universities as well as their quality. Moreover, the capacity of public R&D organisations in the field of Industry 4.0 correlates with the regional industry concentration (Fig. 1), as well as regional projection of the business cycle and labour force shortages (Moravcikova, 2020).

*Figure following on the next page*

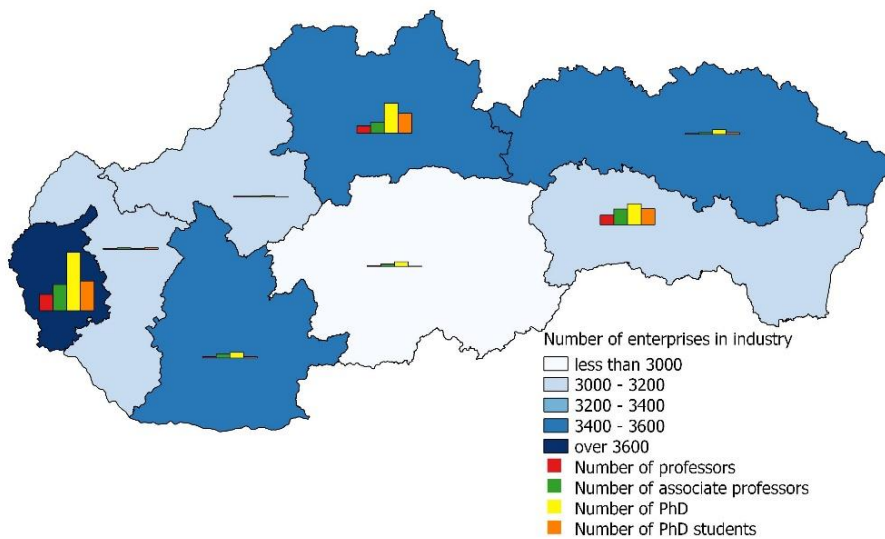

*Figure 1: Regional distribution of industry and gross R&D potential  
(Source: own research)*

### 3.3. International activities – quality check

The involvement of public R&D organisations in international R&D schemes can be considered an indicator of the quality of their R&D activities. The trans-European mechanism Horizon 2020 is an internationally respected programme which supports high-quality projects. From the available databases, projects with relevance to Industry 4.0 were identified via keywords selection. A total of 159 project applications relevant to Industry 4.0 were submitted by Slovak entities, of which 51 were approved. Public R&D organisations submitted a total of 90 project proposals, of which 25 were approved. Some projects included more than one public R&D organisation. Those project proposals relevant to Industry 4.0 were submitted by public R&D organisations to various Horizon 2020 funding schemes (Fig. 2). The highest share of project proposals were submitted to the RIA (Research and Innovation Actions) scheme.

The second most numerous group comprised project proposals submitted to the IA (Innovation Actions) scheme. Approximately 11% of proposals were submitted to the CSA scheme (Coordination and support actions), which supports activities such as standardisation, awareness raising, networking, dissemination, etc. Under the MSCA-ITN mobility scheme (Marie Skłodowska-Curie – Innovative Training Networks), 9% of the project proposals were submitted. Other proposals were submitted under the JTI-ESCEL-IA (Joint Technology Initiative-Electronic Components and Systems for European Leadership-Innovation Actions), MSCA-RISE (Marie Skłodowska-Curie-Research and Innovation Staff Exchange), and MSCA IF-EF schemes, as well as the JTI-ECSEL-RIA or Eranet Cofund Joint Technology Initiative scheme.

Concerning the approved projects submitted by the public R&D organisations, the RIA and the IA are the two most important schemes. Within the approved projects, the percentage of Eranet Cofund and JTI-ECSEL RIA/IA projects was high (12%). Other schemes which have achieved the same 8% share in approved projects are the CSA and the MSCA-RISE.



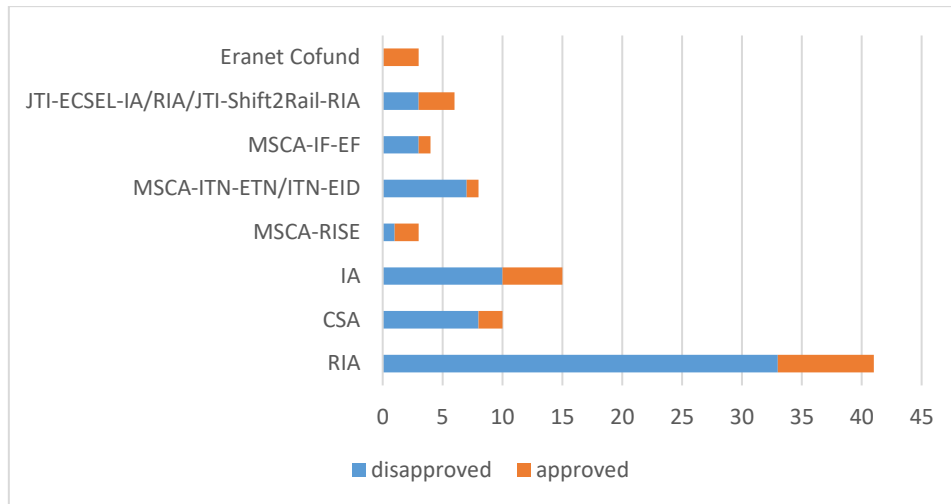

*Figure 2: Number of project proposals and approved projects of public R&D organisations relevant to Industry 4.0 in Horizon 2020 (Source: SCSTI, own research)*

Industry 4.0 keywords were identified up to 106 times in all project proposals submitted by public R&D organisations (Fig. 3). According to the keywords frequency, the project proposals were dealing with the following technology domains: simulation (24), artificial intelligence (19), cyber (15) and cloud (14). These four words were present in up to 62% of cases. On the other hand, another set of keywords was relevant in the case of approved projects. The Industry 4.0 keywords occurred 31 times within all approved projects. The following were mentioned most often: robot (5), artificial intelligence (3), simulation (4) and big data (4). This means that these four technology domains represent the strengths of the public R&D organisations from the international point of view. The lowest intensity of international success (approved project) as well as activities (project proposals) was identified within augmented reality and additive manufacturing.

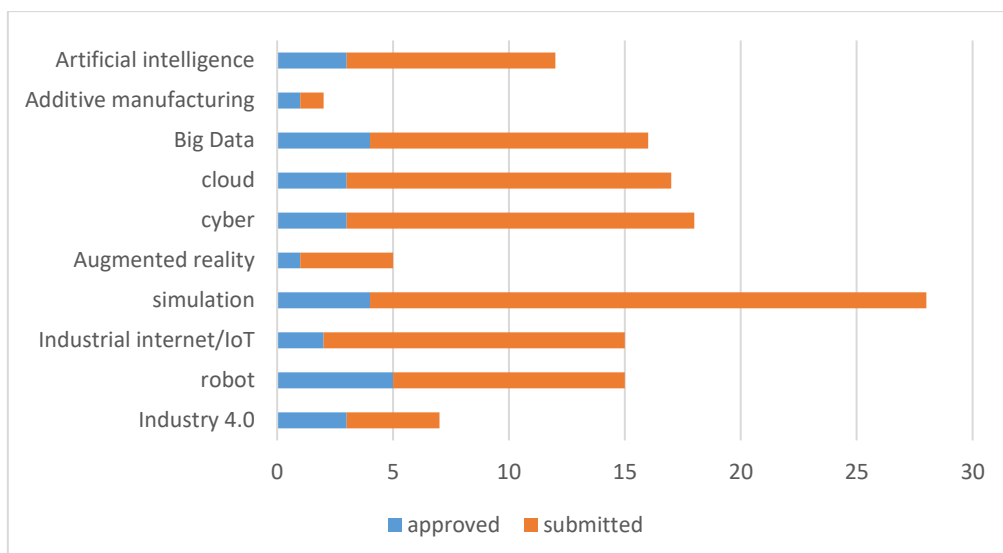

*Figure 3: Occurrence of keywords within project proposals and approved projects in Horizon 2020 (Source: SCSTI, own research)*

According to the keywords mapping, the following organisations are the most successful in the Horizon 2020: the Slovak Academy of Sciences, the Technical University of Košice, the Slovak University of Technology in Bratislava, the Comenius University in Bratislava, and the University of Žilina (Fig. 4).

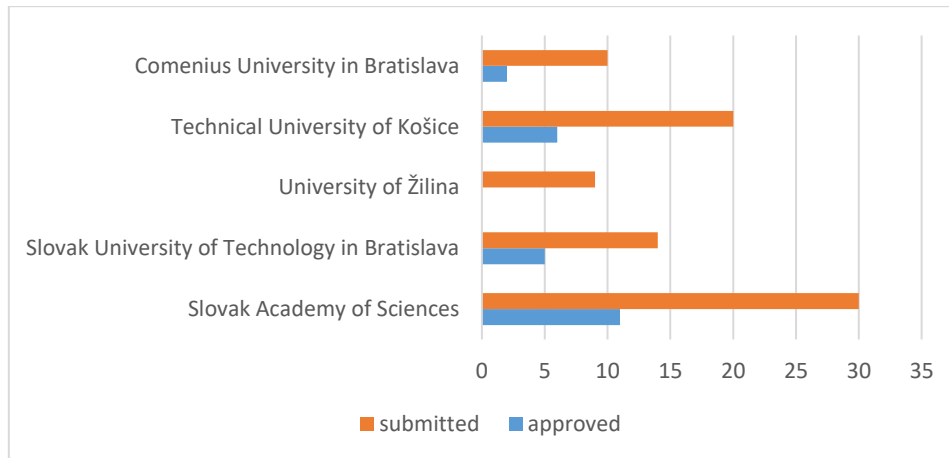

Figure 4: The five most active public R&D organisations in Horizon 2020  
(Source: SCSTI, own research)

The Slovak Academy of Sciences participated in 30 project proposals, while the Institute of Informatics SAS covered 12 of them. The Institute of Informatics SAS is the most successful organisation, since a total of six projects were approved. The Technical University of Košice participated in 20 projects while it was successful in 6 cases. Moreover, the Slovak University of Technology in Bratislava is the key player, listed as a partner or leader in 14 project proposals. A total of five projects were approved under Horizon 2020 schemes. In addition to this, the Comenius University in Bratislava participated in ten projects, two of which were approved. The University of Žilina participated in nine projects, while none were approved. The overall international activities of public R&D organisations under Horizon 2020 can be considered low. From a geographical point of view, project applications under Horizon 2020 with relevance to Industry 4.0 were submitted by organisations from six cities. More than 60% of them had headquarters in Bratislava, and more than 20% in Košice. The same trend was observed for the approved projects. It seems that geographical distribution of the international activities of the public R&D organisations under Horizon 2020 is in line with the identified gross human potential. These findings point to a disproportion between broader gross R&D potential and the ability to involve public R&D organisations in competitive international R&D schemes. As such, RDI policies should decrease this (quality) gap through greater promotion of international activities, supporting high-quality R&D as well as knowledge capitalisation. This also indicates an insufficient average quality of public R&D organisations. On the other hand, the teams involved in Horizon 2020 can be considered as the best domestic teams operating in the technology domains relevant to Industry 4.0.

#### 4. CONCLUSION

The upcoming Fourth Industrial Revolution brings numerous challenges associated with the implementation of state-of-the-art technologies. The development of key Industry 4.0 technologies depends on the capabilities of innovation stakeholders to carry out high-quality R&D projects. Public R&D organisations are considered crucial knowledge providers. In the case of Slovakia, there are public universities, as well as the Slovak Academy of Sciences,

which should be broadly engaged in the development of the technologies related to Industry 4.0. The detailed mapping of the gross potential of the public R&D organisations in the Industry 4.0 showed a large number of human resources that operate directly in the area of Industry 4.0 or in complementary fields. The mapping was carried out by collecting information provided on the websites of individual R&D organisations. The gross potential of human resources of universities in Slovakia in the field of Industry 4.0 consists of 310 professors, 506 associate professors and 1,014 PhD experts. These capacities represent more than 20% of the total human resources in public R&D organisations. The largest human capacities are located at the Slovak University of Technology in Bratislava (STU), the Technical University of Košice (TUKE), and the University of Žilina (UNIZA). They cumulatively allocate approximately 80% of the total number of human resources relevant to Industry 4.0 within public universities. In terms of geographical distribution, most capacities are located in three of the eight regions of Slovakia. There are also some capacities at the Slovak Academy of Sciences, as well as art-orientated universities. Complementarily, the international R&D activity was mapped through the involvement of public R&D organisations in Horizon 2020. Out of the total number of 90 project proposals submitted to Horizon 2020 by a public R&D organisation within the Industry 4.0 topics, 25 were approved. Most project proposals were submitted in the field of simulation, artificial intelligence, cyber and cloud. On the other hand, approved projects were focused on robotics, artificial intelligence, simulation and big data. These areas represent the technological strengths of public R&D organisations from the international perspective. The most successful organisations involved in Horizon 2020 are the Institute of Informatics of the Slovak Academy of Sciences, followed by the STU, TUKE and UNIZA. There are some teams which are successful within Horizon 2020 schemes that can be considered the most valuable part of the public R&D organisations relevant to Industry 4.0. However, the overall activities of public R&D organisations in terms of participating in international R&D cooperation schemes can be considered insufficient. This means that the gap between relatively significant gross R&D potential and incorporation of R&D teams in global knowledge networks (through international projects) is large. Therefore tailor-made policies are needed to improve current status and capitalise on gross potential in real applications as well as increased international cooperation.

**ACKNOWLEDGEMENT:** *This work was supported by grant VEDA No. 2/0002/18.*

#### **LITERATURE:**

1. Beier, G., Ullrich, A., Niehoff, S., Reissing, M., Mabich, M., (2020). Industry 4.0: How it is defined from a sociotechnical perspective and how much sustainability it includes e A literature review. *Journal of Cleaner Production* 259 (2020) 120856
2. Cagáňová, D., Ridzoňová Hlásniková, P., Vraňáková, N., Chlpeková, A.: Intellectual capital as a key factor in the automotive industry. *ACM Mobile Networks and Applications*. online, 03, 1-8 (2019).
3. Chiarello, F., Trivelli, L., Bonaccorsi, A., Fantoni, G. Extracting and mapping industry 4.0 technologies using wikipedia, *Computers in Industry* 100 (2018) 244–257
4. Dalenogare, L.S., Benitea, G. B., Ayala, N. F., Frank, A. G. (2018) The expected contribution of Industry 4.0 technologies for industrial Performance. *International Journal of Production Economics* 204, p. 383–394
5. Guzmán, V.E., Muschard, B., Gerolamo, M., Kohl, H., Rozenfeld, H. (2020). Characteristics and Skills of Leadership in the Context of Industry 4.0.. *Procedia Manufacturing* 43 (2020) 543–550

6. Herčko J., Fusko M., Kotorová Slušná L. (2020). Concept of the Factories of the Future in Slovak Industrial Companies. In: Cagánová D., Hornáková N. (eds) *Mobility Internet of Things 2018. Mobility IoT 2018. EAI/Springer Innovations in Communication and Computing*. Springer, Cham, ISBN 978-3-030-30910-7. p. 251-260.
7. Kagermann, H., Wahlster, W., Helbig, J., 2013. *Recommendations for Implementing the Strategic Initiative Industrie 4.0*. Industrie 4.0 Working Group, Germany.
8. Lee, J., Lapira, E., Bagheri, B., Kao, H., 2013. Recent advances and trends in predictive manufacturing systems in big data environment. *Manuf. Lett.* 1 (1), 38–41.
9. Lezzi, M., Lazoi, M., Corallo, A. (2018). Cybersecurity for Industry 4.0 in the current literature: A reference framework, *Computers in Industry* 103, p. 97–110
10. Moravčáková, K., Baláž, V. (2020). Active Labour Market Policies, the Business Cycle and Labour Force Shortages. In *Economic and Social Development: 51st International Scientific Conference on Economic and Social Development Development, Rabat, 26-27 March 2020: book of proceedings*. p. 14-27. ISSN 1849-7535.
11. Schwab, K., 2016. *The Fourth Industrial Revolution*. Penguin Random House, U.K.
12. Telukdarie, A., Buhulaiga, E., Bag, S., Gupta, S., Luo, Z., (2018). Industry 4.0 implementation for multinationals. *Process Safety and Environmental Protection* 118, p. 316–329
13. Wang, L., Törngren, M., Onori, M., 2015. Current status and advancement of cyberphysical systems in manufacturing. *J. Manuf. Syst.* 37, 517–527. <https://doi.org/10.1016/j.jmsy.2015.04.008>.

## **STUDYING THE FACTORS INFLUENCING THE AUDITOR'S OPINION ON THE BUSINESS CONTINUITY OF THE AUDITED ENTITY**

**Bibigul Amanzholova**

*Novosibirsk State Technical University; Novosibirsk State University of Economics and  
Management, Russia  
amanzholova@corp.nstu.ru*

**Lidiya Nagovitsina**

*Siberian University of Consumer Cooperation; Novosibirsk State University of Economics  
and Management, Russia  
vestnik@sibupk.nsk.su*

**Galina Maksimova**

*Baikal State University; Novosibirsk State University of Economics and Management, Russia  
buh\_ut@bgu.ru*

**Natalia Fadeykina**

*Siberian Academy of Finance and Banking; Novosibirsk State University of Economics and  
Management, Russia  
rektor@nnet.ru*

### **ABSTRACT**

*The article presents the results of the analysis of factors influencing the auditor's opinion on the business continuity. The authors reviewed publications studying factors that determine the inclusion of a disclaimer into the auditor's report. Publications were chosen for the review provided that they contained conclusions drawn from the results of the audit opinions' sample study of companies reports in various countries and industries. Resulting from the review, the following factors were identified as significant: changes in macroeconomic conditions, national models of audit regulation, as well as their transformation. The influence of the evolution of audit standards on the probability of Russian auditors expressing an unsubstantiated opinion on business continuity is investigated.*

**Keywords:** *Audit, Professional conduct, Reporting, The assumption of business continuity*

### **1. INTRODUCTION**

The reporting indicators based on the assumption of business continuity has been a long-standing subject of scientific research and has become an established accounting practice. However, the practical applicability of science-based developments is limited to the following. Management's assessment of the company's ability to continue as a going concern requires judgment at a particular moment of time and with respect to the inherently uncertain outcomes of any events or conditions. The degree of uncertainty associated with the consequences of material events or conditions is always relevant to this judgment. In its turn, the auditor's judgment about the business continuity of the audited entity is rather associated with the uncertainty factor. The degree of such uncertainty increases significantly given that the auditor takes into account events or conditions that affect the ability of the audited entity to run its business continuously, in dynamics – on the reporting date, on the date of signing the statements, on the date of signing the auditor's report. In addition, the auditor's judgment is influenced by factors related to the activities of the audited entity (the size of the company and the complexity of operations, the nature and conditions of the business), as well as external

factors. At the same time, external factors influence not only the assessment of events or conditions, but also the level of professional skepticism of the auditor when collecting and evaluating evidence. The fact is that any judgment regarding past and future periods is based on information available at the moment the judgement is made, *inter alia*, made under the influence of external factors. It is obvious that the auditor's judgment on business continuity included in the auditor's report may influence the conclusions and decisions of the qualified users of the reports. For example, many researchers believe that poor-quality audit, including the erroneous opinion of auditors about the continuity of companies' operations, was among the causes of the global financial crisis in 2008. That is why the formation of such a judgment should result from a dialogue between auditors and actual and potential users of the reports. While the rules of such a dialogue can be defined by audit standards and other regulations, its effectiveness is largely determined by the professional behaviour of the auditor. The above has determined the need to study factors that affect the auditor's judgment on the going concern of the audited entity.

## **2. REVIEW OF SCIENTIFIC PUBLICATIONS IN THE RESEARCH AREA**

The analysis of publications on the stated issues allowed us to draw the following major conclusions. First, the works of Russian and foreign authors pay great attention to the methodological aspects of business continuity audit. This is why the analytical tools required for the audit assessment of the going concern assumption are highly developed. Secondly, the publications of foreign scientists are much more focused, compared to Russian publications, on the influence of specific factors on the manifestation of professional skepticism when making judgments about the continuity of activities. In our opinion, research on the impact of such factors becomes rather relevant in the uncertain environment. In studies on the development of analytical tools for the audit assessment of business continuity, two focuses can be identified. The first focus is on supplementing or detailing events and conditions that may cause significant doubts about the organization's ability to operate continuously. These supplements or details are based on the conclusion that the International Auditing Standard 570 'The Business Continuity Principle' does not fully consider market factors. Researchers believe that market factors significantly enrich audit evidence by predicting the impact of competitors' behaviour on the business activity and performance of the audited entity. Highlighting the second focus, we consider it necessary to note the desire of researchers to improve the quality of audit assessment through the widespread use of statistical methods and methods of economic and mathematical modeling as part of audit procedures in essence [6,5]. In our opinion, the development of audit tools should be synchronized not only with changes in the role of audit in socio-economic systems, but also meet expectations that are formed both at the global level and within national economies. The validity of this conclusion is confirmed by the results of the publications review for the period of 2015-2019, presented in the Scopus and Web of Science abstract and citation databases. An important conclusion of the review is the clear focus on sustainable development. The transformation of socio-economic systems at various levels in accordance with the goals of sustainable development has also affected the auditor's profession. The study of the auditing transformation in the paradigm of sustainable development highlights a new approach to understanding audit as a necessary condition for a "green economy"; expanding the boundaries of audit procedures due to the lack of verification of exclusively financial information to ensure the sustainable development of public companies. The emergence of new subject areas of verification requires new competencies from auditors, since it has been proven that financial reports, as a source of operational indicators of the company, give a one-sided assessment, which does not allow investors and authorities to get a full assessment of the company's business prospects [1].

The study by Li-Chang HSU, Shang-Ling OU, Yih-Chang OU (2015) proved that financial indicators do not provide a complete picture of the company's performance, and in the long term, a positive correlation between social and environmental performance indicators and profit on the stock exchange was found [7]. Some of the results of the review, which made it possible to identify significant external factors, are presented in table 1.

Source	Sampling
<b>Linda, A. Myers, Jonathan, E., Shipman, Quinn, T., Swanquist, Robert, L., Whited (2018) – Measuring the market response to going concern modifications: the importance of disclosure timing [8]</b>	897 companies that first received an audit report with a modification in relation to the going concern (March 2003-may 2014)
<b>Mohammad Noor Hisham Osman, Zaidi Mat Daud, Ahmed Razman Abdul Latiff, Zulkarnain Muhamad Sori (2018) – The impact of management, family, and institution on the auditor's going concern opinion issuance decision [9]</b>	644 Malaysian public companies in a difficult financial situation, that contributed significantly to the development of the country's economy (2006-2012)
<b>Jean Bedard, Carl Brousseau, Ann Vanstraelen (2018) – Investor reaction to auditor's going concern emphasis of matter: evidence from a natural experiment [3]</b>	9,457 companies with reports in SEDAR (electronic document analysis and search system) based on Compustat database (2005-2014)
<b>Sanoran Kanyarat (2018) – Auditors' going concern reporting accuracy during and after the global financial crisis [12]</b>	883 US companies that received an audit report with doubts about business continuity for the first time and 537 failed companies on the Compustat database (2005-2010)
<b>Thomas C.Omer, Nathan Y.Sharp, Dechun Wang (2018) – The Impact of Religion on the Going Concern Reporting Decisions of Local Audit Offices [13]</b>	3623 US companies in respect of which the auditors have not expressed doubts about the continuity of operations 3498 companies whose audit report contains information about non-compliance with the principle of continuity
<b>Feng Chen, Kevin Lam, Wally Smieliauskas, Minlei Ye - (2016) - Auditor Conservatism and Banks' Measurement Uncertainty during the Financial Crisis [2]</b>	1026 observations of US public banks for 2008-2011

*Table 1: Characteristics of studies on the audit assessment of business continuity of companies*

As a result of the review, the factors, that researchers believe to influence the auditor's opinion on business continuity, are highlighted.

1. Due to the fact that the disclosure of doubts about business continuity in the supplemented paragraph of the auditor's report is of particular importance to investors, when making a decision to include the disclaimer, the expectations of investors are taken into account.

2. Professional scepticism of auditors is more evident during the crisis, but returns to the pre-crisis level when the crisis is over.
3. Auditors tend to be more conservative during the financial crisis than in the post-crisis period.
4. When auditing banks with higher risk and uncertain asset valuations, auditors are less likely to make mistakes.
5. The financial crisis affects the behaviour of all auditors, regardless of the scope of audit companies and their industry specialization.
6. Audit firms with offices located in regions with significant religious influence are more likely to modify their opinion based on doubts about business continuity in accordance with a more skeptical assessment of financial, operational and other factors.

Thus, the auditor's judgment about the business continuity of the audited entity is always associated with an uncertainty factor. The degree of such uncertainty increases significantly with the remoteness of the audit report signing date and the event or condition that affects the ability of the audited entity to operate its business continuously. International auditing standards define that judgment about the outcome of events or conditions is influenced by the size of a company and the complexity of its operations, the nature and conditions of its business, and the extent to which external factors affect it. In this regard, it is important to note that external factors influence not only the assessment of events or conditions, but also the professional skepticism of the auditor when collecting and evaluating evidence. The fact, that any judgment regarding past and future periods is based on information available at the moment the judgement is made, *inter alia*, under the influence of external factors, is a striking illustration of such influence. Based on the results of the review, factors that may influence the professional behaviour of auditors at the moment of making a judgment on business continuity are identified. These factors include the dynamics of macroeconomic conditions, national models for regulating audit activities, and the level and nature of operations regulations in the industry in which the audited entity operates. In addition, it is important to highlight a significant factor determining the new approach to the responsibility of audit companies and auditors, the process of transforming the institute of audit in accordance with the goals of sustainable development.

### **3. FACTORS INFLUENCING THE GOING CONCERN OPINION OF AUDITORS IN RUSSIA**

Thus, recognizing the significance of the influence of the external factors on the auditor's judgment on business continuity determines the prospects for the study of a new approach to the content of auditor's professional behaviour. At the end of 2019, the Ministry of Finance of the Russian Federation approved a document that, for the first time in a long period, defined the concept or directions for the development of auditing activities [11]. This document defines that the purpose of audit activity at the present stage is to form and maintain the trust of the business community and society as a whole in the results of providing audit services. It is important to note that this overarching focus is fully consistent with the concept of the system of International Standards on Auditing, which have been applied in Russia since January 1, 2017. The authors agree with the opinion that the state and development of the institute of audit is negatively affected by the imperfection of the system of legal and other regulatory acts, including the instability of legislation affecting audit activities, inconsistency of certain norms. We consider it is fair to say that there has been a recent trend of excessive formalization of the auditing standards, which contradicts the nature of audit. Excessive formalization of the auditing standards contradicts the generally recognized international practice of regulation based on the principles prescribed by the International Standards on Auditing. As a result, this formalization discredits the institution of professional opinion of the auditor.



That is why the evolution of audit standards and the formation and implementation of the concept of external audit quality control are highlighted as key factors affecting the professional behavior of auditors in Russia. The authors are convinced that this is the evolution of standards which should be considered, since the auditing in Russia has walked its way from a complete absence of standards up to the application of the International Standards on Auditing as normative legal acts. In regard to the regulation of issues of the audit assessment of business continuity, the formation and transformation of the legal framework is closely related to the documents regulating the auditor's report. The regulatory documents of each specific stage show the gradual development, complexity and improvement of the auditing standards, as well as the implementation of standards for the assessment of business continuity (table 2).

Standards for the auditor's report	Business continuity audit standards
<b>1996 (25 points)</b>	
Rule (standard) of audit Procedure for preparing an auditor's report on accounting statements	-
<b>2002 (50 points)</b>	
Rule (standard) No. 6 Auditor's report on financial (accounting) statements	Rule (standard) No. 11 Applicability of the business continuity assumption of the audited entity
<b>2010 (75 points)</b>	
Federal Standards on Auditing (FSA) 1/2010 Auditor's report on accounting (financial) statements and forming an opinion on its reliability FSA 2/2010 Modified opinion in the auditor's report FSA 3/2010 Supplementary information in the auditor's report	Rule (standard) No. 11 Applicability of the business continuity assumption of the audited entity
<b>2017 (100 points)</b>	
International Standard on Auditing 700 Forming an opinion and reporting on financial statements International standard on auditing 701 Communicating key audit matters in the independent auditor's report International standard on audit 705 Modifications to the opinion in the independent auditor's report International standard on auditing 706 Emphasis of matter paragraphs and other matter paragraphs in the independent auditor's report	International standard on auditing 570 Going concern

*Table 2: Evolution of standards for auditor's report and business continuity*

It is obvious that the development and improvement of the standards of the auditor's report has led to changes in the requirements for the formation and content of the auditor's report, including in the aspect of business continuity. Thus, at the first stage, the auditor's report reflected an opinion on the reliability of the accounting reports, i.e. on compliance of the accounting reports with the regulations on accounting and reporting in the Russian Federation. There was no a separate standard for the business continuity aspect, but the standard on the auditor's report allows the report to reflect serious doubts about the ability of an economic entity

to continue operating and meet its obligations for at least 12 months following the reporting period. At the third stage, the Federal Standard on Auditing (FSA 3/2010) Supplementary information in the auditor's report was approved, which provides for drawing users' attention to certain circumstances, including those related to doubts about business continuity. Currently, the International Standards on Auditing define in sufficient detail the procedure and options for reflecting information related to the business continuity of the audited entity. To determine the period in which it is possible to assume a significant impact of regulatory changes on the results of the audit assessment of business continuity, the authors used the information in table 2. A scale from 0 to 100 points is used (the first generation of standards is 25, the second is 50, the third is 75, and the fourth is 100). The results of the analysis are shown graphically in Fig. 1.

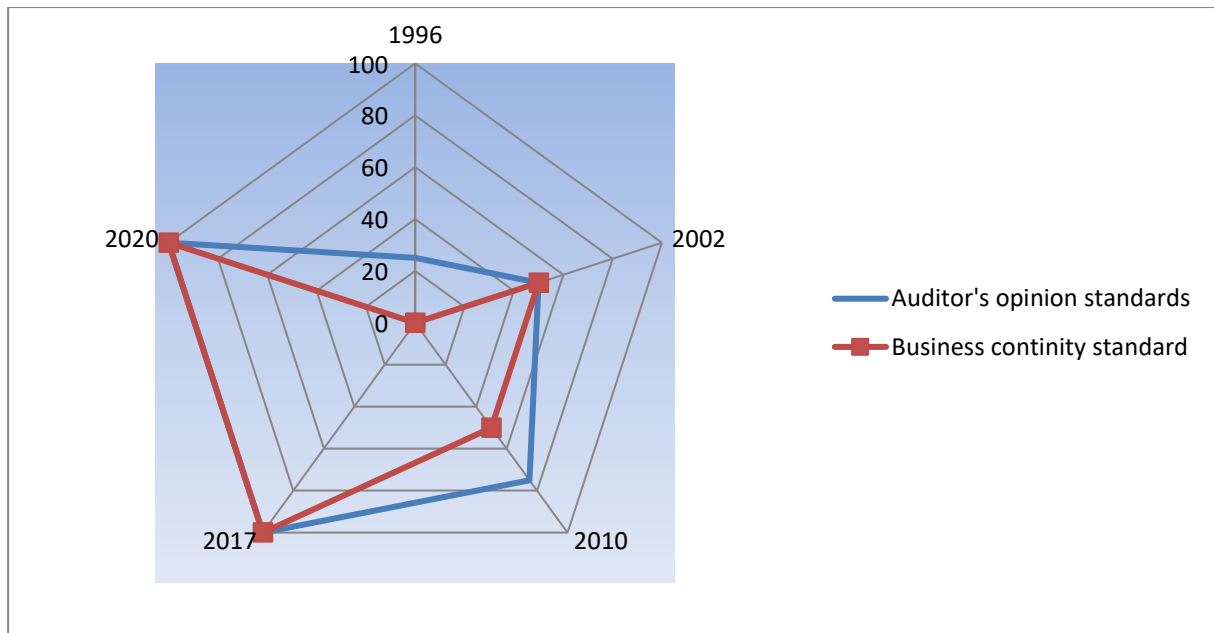

Figure 1: Ratio of generations of auditor's report standards and business continuity for the period 1996-2020.

The information given in Figure 1 allows to identify the period in which it is possible to assume a significant impact of regulatory changes on the results of the audit assessment of business continuity. The periods of 1996 -2002, 2010-2017 have been analysed. In the first period, there is no standard governing the auditor's assessment of business continuity. The choice of the second period is due to the fact that when changing the standards of the auditor's report, the standard Business Continuity was not revised. This situation remained unchanged until the International Standards on Auditing came into force.

To analyze this assumption, we revised the conclusions expressing doubts about the client's ability to continue operating based on the results of external quality control of audit organizations and auditors. The data of the Ministry of Finance for 2010-2017 were used (table 3).

Table following on the next page

Indicators	2010	2011	2012	2013	2014	2015	2016	2017
The percentage of audit opinions expressing doubts about the client's ability to continue operating and indicating significant uncertainty in the client's activities in the total number of issued opinions, %	-	2.6	3.1	3.3	3.2	3.8	4.2	4.6

*Table 3: Dynamics of the share of auditors' opinions with doubts about the continuity of the audited entity's business in 2010-2017*

*(compiled by the authors according to the Ministry of Finance data [10]).*

*Notes: "-" information is not provided in the reports of the Ministry of Finance*

It should be noted that for 2010 there is no information about the results of external quality control of the audit and auditor's opinions expressing doubts about the client's ability to continue operations. In relation to the assessment of continuity, only in 2012 and 2014, violations of the requirements for the auditor's actions to verify the legality of the application of the business continuity assumption by the audited entity in the preparation of accounting (financial) statements were not recognized as typical. In the analyzed period, the share of audit opinions expressing doubts about the client's ability to continue operations and indicating significant uncertainty in the client's activities in the total number of issued opinions increases (2011 – 2.6%, 2017 - 4.2 %). Thus, it can be assumed that external quality control revealed:

- violations of the requirements for the auditor's actions to verify the legality of the application of the business continuity assumption by the audited entity in cases when the auditor reflected doubts about the business continuity in the auditor's report;
- violations of the requirements for the auditor's actions to verify the legality of the audited entity's use of the business continuity assumption in cases where the auditor did not reflect doubts about the business continuity in the auditor's report.

However, both situations may result not only from violations of audit standards, but also violations of professional conduct that requires independence, objectivity, and professional skepticism. Thus, it is obvious that changes in audit standards and approaches implemented in internal and external quality control have an impact on the professional behavior of auditors, since they define the principles of audit activity, the rights and duties of auditors, and also claim the responsibility of auditors. The focus on assessing the satisfaction of requests and expectations of financial reports users is consistent with the principle of mutual (joint) responsibility of all parties to the audit contract. In research on the social imperatives of sustainable development, this principle implies "increasing the responsibility of all economic entities for decisions and results, responsible management, involvement (consideration of requests) of stakeholders, and the formation of a different value system" [4].

In relation to auditing, the implementation of this principle requires professional conduct based on the recognition of shared values and sustainable development. This means that when making decisions about audited financial statements, the criteria for evaluating them are supplemented with new criteria and factors.

#### 4. CONCLUSION

Thus, the article argues for an approach to the study of professional behavior of auditors, which, in contrast to traditional ones, identifies a certain set of factors as variables that determine the quality of the auditor's opinion about business continuity. As a result of the identification of a factor of changes in audit standardization, a period is identified in which a high degree of influence of this factor on the auditors' judgments on business continuity is assumed. This conclusion is confirmed by the results of external quality control, as well as statistics of audit reports containing doubts about the business continuity. However, to test this assumption, it is necessary to build a model of the relationship between the number of audit opinions with expressed doubts about the business continuity and factors that affect the business continuity judgment. Therefore, as prospects for further research, the authors consider the justification of the parameters of such a model, the formation of a set of factors linking the results of the audit with the performance of the audited entities, in respect of which there is doubt about the continuity of activities.

#### LITERATURE:

1. Dobre E., Stanila, G.O. Brad, L. (2015). The Influence of Environmental and Social Performance on Financial Performance: Evidence from Romania's Listed Entities. *Sustainability*, 2015 (Volume 7, issue 3), pp.1-41.
2. Feng Chen, Kevin Lam, Wally Smieliauskas, Minlei Ye. (2016). Auditor Conservatism and Banks' Measurement Uncertainty during the Financial Crisis. *International Journal of Auditing*, 2016 (Volume 20, Issue 1), pp. 52-65.
3. Jean Bédard, Carl Brousseau, Ann Vanstraelen. (2019). Investor Reaction to Auditors' Going Concern Emphasis of Matter: Evidence from a Natural Experiment. *AUDITING: A Journal of Practice & Theory*, 2019 (Volume 38, No. 2), pp. 27-55.
4. Kanaeva, O. A. (2018). Social imperatives of sustainable development. *St Petersburg University Journal of Economic Studies*, 2018 (vol.34, issue1), pp. 26–58.
5. Kogdenko, V.G., Mel'nik, M.V. (2017). Modern Trends in Business Analysis: Studying the Company's Ecosystem, Reviewing the Business Model's Information Content, Evaluating Growth Opportunities. *Regional Economics: Theory and Practice*, 2017 (Volume 16, issue. 1), pp. 38–57.
6. Krasnov, V.D., Kozmenkova, S.V. (2017). Going Concern Principle: The Essence and Economic Conditionality. *International Accounting*, 2017 (Volume 20, issue 19), pp. 1147–1162.
7. Li-Chang HSU, Shang-Ling OU, Yih-Chang OU. (2015). A Comprehensive performance evaluation and ranking methodology under a sustainable development perspective. *Journal of Business Economics and Management*, 2015 (Volume 16(1)), pp. 74-92.
8. Linda, A. Myers, Jonathan, E. Shipman, Quinn, T. Swanquist, Robert, L. Whited. (2018). Measuring the market response to going concern modifications: the importance of disclosure timing. *Review of Accounting Studies*, 2018, (Volume 23), pp. 1512–1542.
9. Mohammad Noor, Hisham Osman, Zaidi Mat Daud, Ahmed Razman, Abdul Latiff Zulkarnain, Muhamad Sori. (2018). The impact of management, family, and institution on the auditor's going concern opinion issuance decision. *International Journal of Economics and Management*, 2018 (Volume 12 (2)), pp. 671-691.
10. Official website of the Ministry of Finance of the Russian Federation. Retrieved 15.04.2020 from <http://www.minfin.ru/>
11. Order of the Ministry of Finance of the Russian Federation of 29.11.2019, number 1592. (2019) *On the Main directions of the development of audit activities in the Russian Federation for the period up to 2024*. Retrieved 15.04.2020 from <http://www.consultant.ru/>

12. Sanoran, Kanyarat. (2018). Auditors' going concern reporting accuracy during and after the global financial crisis. *Journal of Contemporary Accounting and Economics*, 2018 (Volume 14(2)), pp. 164-178.
13. Thomas, C. Omer, Nathan, Y. Sharp, Dechun Wang. (2018). The Impact of Religion on the Going Concern Reporting Decisions of Local Audit Offices. *Journal of Business Ethics*, 2018 (Volume 149), pp. 811–831.

# LEGAL IMPACT OF ROBOTS IN CIVIL LIABILITY AND TAXATION: WHAT WE KNOW, TRENDS AND CHALLENGES

**Catia Marques Cebola**

*IJP-IPLeiria – Polytechnic of Leiria, Portugal  
catia.cebola@ipleiria.pt*

**Cristina Sa**

*CARME – Polytechnic of Leiria, Portugal  
cristina.sa@ipleiria.pt*

**Jose Luis Martins**

*ESTG – Polytechnic of Leiria, Portugal  
jose.martins@ipleiria.pt*

**Tiago Azevedo Ramalho**

*CIJE – FDUP / Polytechnic of Leiria, Portugal  
tiago.ramalho@ipleiria.pt*

## **ABSTRACT**

*Robotics is an unavoidable reality in today's global society. Nevertheless, issues relating to the civil liability and taxation of robots still represent an important field of scientific research. According to the International Robotics Federation, 420,870 units of industrial robots were sold in 2019 and in Europe the average density of robots in industry was 14% per 10,000 employees in 2018. This study aims to analyse the legal concerns of robotization (introduction of robots in organizations) at civil and tax liability level. To this end, will be made a compilation of legal prescriptions which may undergo changes due to the progressive robotization in Portugal. Based on this legal compilation, will be studied which legal changes have to be introduced or if they are necessary, in order to produce a positive balance between the inevitable changes operated by robotization (e.g. reduction of current jobs, tax revenues decrease or responsibility disclaimer for possible damage caused by robots) versus the insurmountable need for tax revenue so that the State can continue to provide quality public services and implement public policies that are fundamental to the country's sustainable development. Legal regulation is the path outlined in the European Commission's White Paper on Artificial Intelligence presented on 19/02/2020, which supports a regulatory approach with a dual objective of promoting robotization and address the risks associated with certain uses of this new technology. Analysing how legislation at civil and tax liability level should serve to compensate and rebalance the impact of robotization in Portugal is the basis of this paper.*

**Keywords:** *Civil liability, Legal Impact, Robots, Taxation*

## **1. INTRODUCTION**

Artificial Intelligence (AI) has evolved to enable robots with decision-making capacity (even with ethical content) and machine learning systems have given way to deep learning systems, such as those currently used in Google Translate or Alexa's Amazon (Matthias, 2004). This evolution has raised the fear of the progressive robotization of society, with some considering that robots will end up destroying humans, and others defending that robots will allow humanity to reach a new evolutionary stage (Cabral, 2018). The 2020 European Commission's White Paper on Artificial Intelligence points out several advantages of robotics such as the improvement of healthcare or the increase of Europeans safety.

However, since most tax and social security systems are based on a strong contribution from work-related taxes, and if robotics causes a reduction of workplaces, then countries face a double problem when social benefits have to increase (e.g. due to unemployment) and tax revenues decrease. It is, therefore, necessary to build a scenario in which a right balance between the positive effects and the negative impact of robotization is created, as proposed by the Sustainable Development Goals of the UN 2030 Agenda. The key to build this balance lays in legal regulation. In this sense the European Parliament's Civil Law Resolution on Robotics states that the European industry could benefit from an efficient, coherent and transparent approach to regulation at Union level, providing predictable and sufficiently clear conditions under which enterprises could develop applications and plan their business models on a European scale while ensuring that the Union and Member States maintain control over the regulatory standards to be set, so as not to be forced to adopt and live with standards set by third countries. Bearing in mind this context, this paper aims to analyse the current Portuguese legal framework regarding civil liability and taxation laws in order to understand if robotization and the inherent problems are solved by it or if it is necessary to create new and specific regulations in this field.

This analysis will allow to develop legal guidelines to be considered by Portugal, regarding the regulation of robotization in the area of civil liability and taxation. In general, existing studies focus on the impact of robots on employment (Carbonero *et al.*, 2018). This paper does not aim to be a merely descriptive study of robotics impact at legal level, but instead proposes to study how legislation can be a tool to convert the potential negative effects of robotization into positive results, supporting the improvement of the population's quality of life and of essential public services. Accordingly, it aims to answer the question of whether the current legal framework is prepared to respond to the implications that arise from robotization or whether it is necessary to adapt national legislation to this new scenario. The paper's analysis is restricted to civil liability and taxation of robots. The first one answers the question of damage compensation caused by robots, thus promoting social confidence and admission that robots are able to perform tasks increasingly linked to the life of each citizen (e.g. at the health level). The second topic addresses the potential negative effects of robotization and the need to compensate for the loss of tax revenue by countries as a result of labour taxation decrease. In addition, both civil liability regulation and tax policies at robotics level have not yet been assessed (Abbott & Bogenschneider, 2018). The main goal of this paper is, therefore, mapping the general problems raised by robots using, regarding civil liability and taxation having in mind the Portuguese framework.

## **2. ROBOTIZATION CIVIL LIABILITY**

In a legal perspective, robotics analysis is more phenomenological than dogmatic since an aspect of social life is studied from a legal and a propaedeutic point of view (Silva, 2017). Based on Asimov's Laws (1950) and in order to ensure a safe coexistence between robots and humans, studying the civil liability of robots is imperative. The precautionary principle and the inherent duty to seek and take the necessary measures to avoid damage in the face of an unknown event with harmful potential must be taken into account (Silva, 2017). The paradigm may be to assume an acceptable risk margin in a cost-benefit perspective, which is compensated through objective or risk liability rules (Marques, 2007; Barbosa, 2020). Regarding non contractual civil liability two alternatives can be discussed: in one hand, the possible liability of the robot itself; and, on the other hand, the liability of someone for damages caused by robots (Silva, ANO; Cabral, 2018). In what terms the current Portuguese framework covers damages compensation caused by robots is then analysed.

## 2.1. The liability of the robot

The liability of the robot itself is excluded by Portuguese law, since robots are not granted legal personality. This formal qualification as a “person” is essential for the attribution of rights and obligations and without it the robot cannot be subject to liability [for further development, see Schirmer (2016)].

## 2.2. Responsibility for the robot: liability of the robots’ user or beneficiary

Once the possibility of apportioning damages directly to robots is *lege lata* removed, it is important to assess in what terms the common civil liability regime allows the attribution of the damage caused by the robot to someone who may be subject to liability. Roughly speaking, we can distinguish two typical groups of persons: those who use the robot, sometimes using it themselves and other times benefiting from its activity, giving way to the possible application of the common non-contractual civil liability regime (“tort law”); those who program or produce the robot, and may eventually respond under the regime of the producer liability. It is necessary to start by asking the possible liability of the user or beneficiary of the robot's activity. A distinction will be made between the non-contractual liability regime and the contractual liability regime.

### 2.2.1. Non-contractual liability

At this level it is important to determine the possible liability for the use of robots under the common liability regime (Articles 483 et seq. of the Portuguese Civil Code). We can distinguish between strict liability and liability for wrongful acts.

Strict liability could only take place if the robot fell into one of the forms of responsibility specifically provided for, which is not the case [Article 483(2)]. On the one hand, liability for the acts of an agent under the principal's responsibility is to be excluded, since it would presuppose the agent’s own liability [Article 500(1)]. On the other hand, a possible strict liability in the proper sense (Articles 502 et seq.) is also to be excluded, since the robot is not framed in any of the categories mentioned there: “animals” (Article 503), “vehicles” (Articles 503 et seq.) or “electric energy or gas” (Articles 509 and 510).

Therefore the allocation of damage can only take place under the common civil liability regime. Thus, imputation of responsibility can only take place if, in one way or another, it can be considered that the damage caused by a robot is still causally attributable to someone's behavior. The two main difficulties arising may be measuring a “human behavior”, namely when the user or the beneficiary of the robot's activity cannot easily predict the direction of its activity (and, thus, the robot is more viewed as an agent of the harmful conduct, rather than as an instrument available for a person to use); and the possible lack of reprehensibility of the user's conduct (“fault”). However, the non-contractual liability regime opens up some framing possibilities:

- a) With regard to the existence of human behavior on the part of the user or beneficiary of the robot, the respective responsibility for omission must be considered, pursuant to Article 486, for not having performed the necessary acts to prevent damage by the robot. Some relevant portuguese lawyers apply therefore the german concept of “*Verkehrssicherungspflichten*” [see Cordeiro (2010)].
- b) With regard to the assumption of personal fault, it should be noted that, in the common terms of civil liability, reprehensibility of the agent's behavior is measured by a general standard of a *bonus pater familias* in the circumstances of the case (Article 487(2)) [see Prata, 2000].



In addition, the use of a robot may, in certain cases, lead to the fulfillment of the provisions of Article 493, paragraph 1 (presumption of fault, when the damage results from the thing under the person's guard) or paragraph 2 (presumption of fault in the event of dangerous activities). In the common non-contractual civil liability regime, there is no limitation on damages eligible for compensation. The great weakness of the general non-contractual civil liability regime stems, however, from the fact that it is not associated with any system of guarantee of liability that makes it possible to tackle the eventual under-capitalization of the debtor.

### *2.2.2. Contractual liability*

It is also possible to consider the contractual liability (Articles 798 et seq.), which can only take place when there is an obligation already constituted, namely by contract. In this case, the relevant criterion for the formulation of a liability regime is the fulfillment or non-fulfillment of the obligation. Thus, in the event that the debtor, in the course of performing the debt, causes damage in the sphere of a third party ("positive breach of contract"; "breach of protection duties"), even if such damage has been caused by a robot used in the performance of the contract, the debtor will answer for them. It should be stressed that in contractual liability, the fault of the debtor is presumed, pursuant to Article 799(1). In common contractual civil liability regime there is also no limitation on eligible for compensation damages (Costa, 2009).

### **2.3. Liability of the robots' producer: can the robot be a defective product?**

Council Directive 85/374/CEE, of 25 July 1985 concerning liability for defective products was transposed in Portugal by the Decree Law 383/89, of 6 November (amended by Decree Law 131/2001, of 24 April). Under this framework, the producers are liable and should compensate for damages caused by the defect in a product they have put into circulation for economic purposes, regardless of fault. Consequently, the injured person only have to prove the damage, the defect and the causal relationship between defect and damage. Considering a robot as a product, is possible that several situations of damage caused by defective robots can have solution in this legal regimen. Nevertheless, the legal requirements demanded by the Directive 85/374/CEE and by the Decree Law 383/89 can let some damages without compensation, as the Report from the European Expert Group on Liability and New Technologies Group identified (European Union, 2019). In first place both legal documents only apply to movable objects, even when incorporated into another movable or immovable object. So, damages caused by defective services, such as software updates, are excluded (Cabral, 2018). In addition, no duty of monitoring the products after putting them into circulation is established and the producer' control may be limited in self-learning robots or when damages were caused by a lack of upgrades that the injured person should have made. These limitations reveal that a specific legal regime should be approved in order to overcome unaccountability cases. This was the solution already adopted regarding active implantable medical devices in Directive 2007/47/EC and in the Portuguese Decree Law 145/2009, of 17 June. One of the main innovations of this Law was the implementation of a National System of Surveillance of medical device after putting it in circulation in order to reduce possible future damages (Raposo, 2013). This highlight the need for out of the box solutions and specific legal regimes to overcome specific problems raised by robotics.

### **2.4. Regulation Proposals regarding Civil Liability of Robots**

In conclusion, it should be noted that the legal solutions put to the Commission by European Parliament (paragraph 59 of European Parliament's Resolution of 16 February 2017 with Recommendations to the Commission on civil law provisions relating to robotics [2015/2103(INL)]) would always require a legislative amendment and could not be obtained by interpreting the current Portuguese law.

The Portuguese legal framework in force in general covers damage situations caused by robots. Nevertheless, in some situations a corrective or extensive interpretation may be necessary in order to cover certain situations such as the robot defects discovered after it was placed on the market. This leads to undesirable legal uncertainty and insecurity. Thus, regulation will be the way forward to ensure higher levels of legal protection and foster the use of robots. New solutions to new problems should be thought. Establishing an obligatory insurance to robot users is the solution proposed by many (see points 57 et seq. of the EP Resolution). But insurers will surely try to find reasons to disclaim liability and in this situations a “robots’ compensation fund” to unidentified or uninsured technology, like the one that exists in the vehicle sector, is the solution suggested to redress damage caused. Who and how will finance this compensation fund is not yet answered. Creating a special tax on the robot industry that finances the mentioned fund may be the solution.

### **3. TAX PERSPECTIVES OF ROBOTIZATION**

Existing research, data and forecasts point to a high degree of uncertainty about the impact of massive implementation of AI and robots in the economy. However there is a certain unanimity in the fact that the specific characteristics of each country will have a significant influence on the mode, intensity and speed at which the AI will be introduced in each economy. The fact is that the entry of AI and robots in our life is a reality and it will generate relevant changes in legal, economic and social systems. Robots (as well as several other technologies based on AI) are increasingly becoming a reality in organizations and, in many cases, replacing people in traditional human activities that, for a long time, were considered “safe” in terms of substitution by automation. A set of factors may favour or hinder the spread introduction of different technologies. Market forces driving the relative prices of capital and labour play an important role in determining the profitability of investing in labour-replacing technologies. Countries with relatively low labour costs, for instance, have witnessed a slower process of automation and, also for that reason, do not display a similar pattern of job polarization as higher industrialized countries. Institutional norms and regulations – for example, product and labour market regulations as well as safety, medical and ethical standards – may prevent certain technologies from becoming prominent in certain countries (OECD, 2017; OECD, 2019). Consumer and societal preferences, as well as ethical norms, will play a crucial role in determining the diffusion of labour-replacing technology.

#### **3.1. Robotization: potential benefits**

The intensification of automation brings with it a set of potential benefits for organizations. We can highlight: automation of manual and repetitive tasks (this automation of tasks allows employees to focus on tasks with greater added value); reduction of human error; processing tasks and creating information more quickly; improvement in the end user experience in the use of data and information; improvement in forecasts on activities related to productivity; high potential of robotics in terms of improving safety at work, by transferring dangerous and harmful tasks from humans to robots; possibility to incorporate the principles of circular economy in robotics policies; possibility of having a positive impact on the environment, especially in some sectors of activity, through process optimization and precision activities. (IFR, 2018; Ferreira, 2018).

#### **3.2. Robotization: increased concerns**

However, the mass application of AI also causes increased concerns in several domains like: job stability (specifically for unskilled labour) and wages; issues related to economic equality and income redistribution; impact on tax revenue (and, if taxation is introduced in robots, it may create restrictions on innovation); potential to create a set of new risks due to the growing

number of interactions between humans and robots in the workplace; responsibility of AI consequences (Abbott & Bogenschneider, 2018; Schwab & Samans, 2016; Guerreiro *et al.*, 2019). Regarding all these increased concerns, Bottone (2018), following the World Economic Forum<sup>1</sup>, lists nine points relating to roboethics: 1. Probability of more unemployment (the most discussed topic in the economic literature); and, as a consequence, humans will have more free time if machine are performing productive activities; 2. Inequality (using AI, increased wealth will be created thanks to machines, raising the question how this wealth is redistributed); 3. Humanity (AI is already modelling, and will continue to affect the way humans interact); 4. Artificial stupidity (mistakes are always possible by a machine); 5. Incapacity of AI to distinguish between a simple task and human rights (for example, in predicting future human criminal behaviour, machine could discriminate and act against people selected as probable criminal); 6. Security (possibility to use robots for malicious activities, such as war or terrorist attacks); 7. Evil genies (how do we defend against unintended consequences?); 8. Singularity of humans (we must consider what to do at the point in time when human beings are no longer the most intelligent beings on earth); 9. Robots rights (once we consider machines as entities that can perceive, feel and act, the next natural step is to consider their legal status. Should they be treated like animals of comparable intelligence?). As demonstrated, it is a fact that the intensification of automation, particularly robotization, has increased concerns in various domains. In this work we highlight the consequences on employment and on tax revenues. Regarding to employment there are concerns about: the number of jobs that will be lost, referred as “technological unemployment” (expression popularized by John Maynard Keynes in the 1930s), as well as the number that will be created, which worker skills will be deemed necessary or redundant, and how humans and robots will interact in the workplace are some of the challenges associated with robots (Abbott & Bogenschneider, 2018; Schwab & Samans, 2016; Guerreiro *et al.*, 2019; Carbonero, *et al.*, 2018). The fear of technological unemployment is real, but is it rational? The answer to this question is not unanimous (Ferreira, 2018; Cabral, 2018). Despite the public increasing concern, this fear is overstated, and it is not likely that we will assist an overall job loss, because the technology will also create several opportunities, creating new and additional jobs (Mazur, 2019; Kletzer, 2018; IFR, 2017).

### 3.3. Robotics: taxation perspective

Taxation and the effect on tax revenues is the second area of concern that is addressed in this work. It is a fact that taxation influences the allocation of resources in the economy, affecting the way these resources would be allocated in the absence of taxation, transferring resources from people and companies to the State. In turn, the State uses these resources in the society. Robotics raises issues related with economic equality, income redistribution and tax revenues. Currently, robotics is an issue of great discussion in the taxation domain and there is also no consensual opinion about it. For example, Abbott & Bogenschneider (2018:150) state that “Robots are simply not taxpayers, at least not to the same extent as human workers”. Auerbach (2006) considers that taxation of labour income is more efficient than the taxation of capital income. Several authors consider that robot taxation will have a negative impact in innovation (Mazur, 2019). Various solutions can be embraced and are under discussion at international level. According to Abbott & Bogenschneider (2018:151) «Tax “neutrality” between human and automated workers could be achieved through some combination of disallowing corporate tax deductions for automated workers, creating an “automation tax”». In fact, in the search for answers for the presented problems (some already present, others possible), there have already been several calls at the global level to consider taxing robots (this trend has already led to the submission of tax proposals on robots – for example Delvaux (2016), Draft Report with Recommendations to the Commission on Civil Law Rules on Robotics). With this framework,

<sup>1</sup> Available at: <https://www.weforum.org/agenda/2016/10/top-10-ethical-issues-in-artificial-intelligence/>

there is an urgent need to evaluate the arguments for and against the taxation of robots, defining the best way to deal with the possible design and the effects of the introduction of a robot tax. This possible taxation should be taken into account when considering the previously mentioned “robots’ compensation fund”. Regarding taxation policies, if robots are replacing the labour force, a fall in tax revenue should be expected, as labour taxes represent a significant portion of tax revenue. In addition, if robotization seems to put at risks mainly routine and low skilled workers, governments will need growing public resources to invest in educational and training system. Also social security systems must be reinforced (Floridi, 2017; Abbott & Bogenschneider, 2018; Ionescu, 2019). Oberson (2017) argues that, as a consequence of automation introduction, granting a legal personality to robots is a possibility. This way, the potential implications of a tax on robots, or on the use of such robots, must be considered (of course, this would require a clear definition of robots, which could be based on the use of artificial intelligence, combined with a sufficient level of autonomy). Regarding Portugal, there is still no legislation to framework this “new” reality.

### *3.3.1. Taxation: arguments in favour*

Despite the growth of AI being an issue for discussion in the taxation perspective, there is no consensual opinion if they should pay taxes or not. Ryan Abbott<sup>2</sup> states that taxing robots is not a crazy idea! At the Emtech NEXT 2019 conference<sup>3</sup>, put on by MIT Technology Review, he presented a long list of arguments in favour of robots taxation: all jobs, including complex jobs, have a lot of routine tasks included, and if automation technologies free up the time of these workers on some tasks, it may not be need as many of them; if robots and humans cost the same amount, tax policies make robots cheaper to employ (they have no payroll tax - this argument is of interest in countries where the labour cost is high); robots don’t pay income or sales taxes either (income tax revenues is one of the higher source of tax revenues for in several countries); even if we do find a new job for everyone who loses one to automation, the “disruption” in the meantime may be very painful, and governments will have to spend money retraining and providing social benefits; since the greatest risks of automation are to the middle-class jobholder, we need to do something ambitious to help this vulnerable group; tax revenue we will lose from automation has to be made up somewhere; tax revenue from robot taxes could also fund guaranteed minimum incomes; automation will generate lots of wealth, but it shouldn’t come at the expense of the most vulnerable.

### *3.3.2. Taxation: arguments against*

Also at the Emtech NEXT 2019 conference, Ryan Avent<sup>4</sup> presented a long list of arguments against robots’ taxation: jobs aren’t being lost at the rate hoped or expected - so perhaps a tax on robots isn’t needed at all; robots are primarily used in manufacturing, and not that much in the services sector; total factor productivity has been growing slowly, so it’s hard to see that robots are a problem; employment percentages are very high in many industrialized countries which are intense users of robots; if we discourage robots, it’s not clear that jobs will stay in those countries anyway, as they may be outsourced to countries with lower wage rates; we also have to consider difficulties of implementation in robot taxation - it would require lots of work by people to ensure robots are taxed appropriately; rather than tax a specific kind of capital that improves productivity, why not institute a wealth tax; if robots, autonomy, and AI could do great things for humans, potentially bringing about more leisure, fewer accidents, and so forth, we risk losing these benefits if we tax robots.

<sup>2</sup> Ryan Abbott, professor of law and health sciences at the University of Surrey in the UK.

<sup>3</sup> Available at: <https://events.technologyreview.com/video/watch/robot-tax-debate-abbott-avent-lichfield/>

<sup>4</sup> Ryan Avent, economics columnist for the Economist.

#### 4. CONCLUSION

AI advances is a reality with strong impact in all countries. The real impact it will generate is still unknown. However, it is certain that on a civil liability level and regarding to taxation rules the existing framework may not have appropriate answers. Public tax revenues in Portugal, as well as in other countries, are very dependent of the labour taxes and contributions. The hypothesis that robots will replace thousand of jobs and generate unemployment is a matter of interest and a domain under discussion in institutions like EU and OECD. There is a long list of arguments in favour and against taxation and until now there is no consensual opinion. For example, in 2017, South Korea has introduced the world's first tax on robot. It is not a direct tax on robots but is a reduction on the tax deduction benefits for investment in automation. Tax issues related to robots taxation goes beyond the borders of any particular country, there it should be analysed in an international perspective. On an international level it should be established a generalized definition of robots. Also an appropriate treaty allocation rule should be defined. In terms of civil liability, the Portuguese current legal regime is adaptable to the damage compensation caused by robots, but not perfectly. The possibility that an extensive or corrective legal interpretation may be necessary or that some civil liability situations may go unanswered justifies the provision of a specific legal regime for compensation of damages caused by robots. Legal regulation is, moreover, the path indicated by the European Union in the various recommendations in this field. Specific and suitable solutions are needed and should be considered. Compensation funds is a remedy proposed by the **European Expert Group on Liability and New Technologies Group of the European Union. How to finance this fund is still unclear, but also shows how integrated solutions between various areas are relevant. Therefore this paper integrates an analysis in terms of civil liability and taxation. Financing the compensation fund with the creation of a specific tax for the robots use is a proposal.** The reflection presented in this paper raises the importance of the debate and analysis, but also the relevance of integrated solutions since robotization is general (in all fields) and global (in all countries).

#### LITERATURE:

1. Abbot, R. & Bogenschneider, B. (2018). Should Robots Pay Taxes? Tax Policy in the Age of Automation. *Harvard Law & Policy Review*, 12, pp. 145-175.
2. Auerbach, A. J. (2006). Who Bears the Corporate Tax? A Review of What We Know. *Tax Policy and the Economy*, 20, Poterba.
3. Bottone, G. (2018). A Tax on Robots? Some food for thought. *DF Working Papers*. Available at: [https://www.finanze.gov.it/export/sites/finanze/it/.content/Documenti/Varie/dfwp3\\_2018.pdf](https://www.finanze.gov.it/export/sites/finanze/it/.content/Documenti/Varie/dfwp3_2018.pdf)
4. Cabral, T. S. (2018). Robotics and AI in the European Union: opportunities and challenges. *UNIO - EU Law Journal*, 4(2), pp. 135-146.
5. Carbonero, F., Ernest, E., Weber, E. (2018). Robots worldwide: The impact of automation on employment and trade. *International Labour Organization. Research Department Working Paper*, N. 36.
6. Cordeiro, A. M. (2010). *Tratado de Direito Civil Português II-II*. Coimbra: Almedina.
7. Costa, M. J. A. (2009), *Direito das Obrigações* (12. Ed). Coimbra: Almedina.
8. Delvaux, M. (2016). *Draft Report with Recommendations to the Commission on Civil Law Rules on Robotics* [2015/2103(INL)]. Brussels.
9. European Union (2019). *Report from the European Expert Group on Liability and New Technologies Group*. doi:10.2838/573689.

10. Ferreira, R. (2018). Os novos desafios da inteligência artificial: A tributação dos robôs. *Direito na Lusofonia. Direito e Novas tecnologias. 5º Congresso Internacional de Direito na Lusofonia*. Março. Edição Escola de Direito da Universidade do Minho e Jusgov, pp. 459-468.
11. Floridi, L. (2017). Robots, Jobs, Taxes, and Responsibilities. *Philosophy & Technology, Mar2017*, 30(1), pp.1-4.
12. Guerreiro, J., Rebelo, S., Teles, P. (2018). Should Robots be Taxed? *NBER Working Papers*, N. 23806. Available at: <http://www.nber.org/papers/w23806>.
13. IFR – International Federation of Robotics. (2017). The Impact of Robots on Productivity, Employment and Jobs. *IFR Positioning paper*. Available at: [https://ifr.org/img/office/IFR\\_The\\_Impact\\_of\\_Robots\\_on\\_Employment.pdf](https://ifr.org/img/office/IFR_The_Impact_of_Robots_on_Employment.pdf).
14. IFR – International Federation of Robotics. (2018). Robots and the workplace of the future. *IFR Positioning paper*. Available at: [https://ifr.org/downloads/papers/IFR\\_Robots\\_and\\_the\\_Workplace\\_of\\_the\\_Future\\_Positioning\\_Paper.pdf](https://ifr.org/downloads/papers/IFR_Robots_and_the_Workplace_of_the_Future_Positioning_Paper.pdf).
15. Ionescu, L. (2019). Should Governments Tax Companies' Use of Robots? Automated Workers, Technological Unemployment, and Wage Inequality. *Economics, Management, and Financial Markets*, 14(2), pp. 64–69.
16. Kletzer, L. (2018). The Question with AI Isn't Whether We'll Lose Our Jobs - It's How Much We'll Get Paid. *Harvard Business Review*, January 31.
17. Mazur, O. (2019). Taxing the Robots. *Pepperdine Law Review*, 46(2), pp. 277-330.
18. Prata, A. (2000), Responsabilidade civil: duas ou três dúvidas sobre ela. *Estudos em comemoração dos cinco anos (1995-2000) da Faculdade de Direito da Universidade do Porto*. Coimbra: Almedina.
19. Oberson, X. (2017). Taxing robots? From the Emergence of an Electronic Ability to Pay to a Tax on Robots or the Use of Robots. *World Tax Journal*, 9(2), pp. 247-261.
20. OECD (2017). *How technology and globalisation are transforming the labour market, In OECD Employment Outlook 2017*. OECD Publishing, Paris. [https://doi.org/10.1787/empl\\_outlook-2017-7-en](https://doi.org/10.1787/empl_outlook-2017-7-en).
21. OECD (2019). *OECD Employment Outlook 2019: The Future of Work*. OECD Publishing, Paris. <https://doi.org/10.1787/9ee00155-en>.
22. Schirmer, J. (2016), Rechtfähige Roboter?. *Juristenzeitung*, 13/2016, pp. 660-666
23. Schwab, K., Samans, R. (2016). The Future of Jobs: Employment, Skills, and Workforce Strategy for the Fourth Industrial Revolution. *Global Challenge Insight Report*.

## COMPOSITION AND DISTRIBUTION OF INNECA LARVAE (ODONATA LARVAE) IN LAKES AND WATERFALLS

**Sanubar Guliyeva**

*Azerbaijan State Economic University, UNEC, Azerbaijan  
sama2013@bk.ru*

### **ABSTRACT**

*The article provides information on the species composition and reproduction of odonata larvae in the lakes and ponds of vicinity Kura, the results of the 2012-2017 studies. Odonata larvae form the basis of fish food that is essential for wild, especially predatory fish. The main purpose of the research is to study the species composition and number of odonata larvae in lakes and ponds of vicinity Kura. Ponds more often found in downstream of the Kura river. We are going to talk here about the ponds of vicinity of Kura river. It is known that rivers, especially large rivers, can be affected by various natural factors - strong flood waters, soil crashes or landslides, earthquakes, volcanic eruptions, etc. From time to time under the influence of these type of natural factors, it changes its home bed and the process is still ongoing. People are playing a great role in these processes such as construction of hydroelectric power stations, change of riverbed, etc. In the process of changing river basins, independent water reservoirs or streams are often formed in or around the river's old bed. Water leaks formed in this way or other are either linked to the river or completely cut off from the main source. Thus, the ponds are an aquatic ecosystem been formed in the riverbed or in adjacent areas. There were several dozen of such ponds on the banks of the Kura and Araz rivers, especially in Yevlakh, Imishli, Kurdamir, Sabirabad and other districts. Since, the 50s of the 20th century, as a result of the regulation of the Kura and Araz rivers, most of the streams have dried up, while the water regime has changed dramatically.*

**Keywords:** *Biomass, cypress, groundwater, larva, material, odonata, predator, spleen*

### **1. INTRODUCTION**

Odonata larvae form the basis of the diet of important fish, especially carnivores. The main purpose of the research is to study the species composition and quantity of needle larvae in the Kura river lakes and streams. Lakes are water-borne tracts that form small streams in the old bed of large rivers or in areas where they flow. As the name suggests, such water does not flow. Its fauna also replicates the fauna of the river, which primarily forms the water fauna in the immediate vicinity, and, over time, acquires a characteristic of river-lakes and finally lakes. Small rivers do not have the ability to form ponds. From this point of view, we should look for ponds near the Kura and Araz rivers or in their tributaries.

#### **1.1. Forming of ponds**

Ponds are more common in the lower reaches of the Kura River. Here we talk about the ponds around Kura. It is known that rivers, especially large rivers, can be affected by various natural factors - strong flood waters, soil crashes or landslides, earthquakes, volcanic eruptions and so on. From time to time under the influence of such natural factors they change their home bed, and the process is still ongoing. People play a great role in this process: construction of hydroelectric power stations, change of riverbed, etc. In the process of changing river basins, independent water reservoirs or streams are often formed in or around the river's old bed. Reservoirs formed in one way or another remain either connected to the river or completely cut off from the main source. Thus, the pond is a reservoir formed in the riverbed or adjacent areas and represents a stagnant aquatic ecosystem.

There were dozens of such reservoirs on the banks of the Kura and Araz rivers, especially in Yevlakh, Imishli, Kurdamir, Sabirabad and other regions. Since the 50s of the 20th century, as a result of the regulation of the Kura and Araz rivers, most of the streams have dried up, while the water regime has changed dramatically.

## 2. MATERIALS AND METHODICS

The methodology adopted in hydrobiological studies was used to collect materials in ponds (Yetim-Kur, Garaoglan, Garhun, Marzli) in lakes (Aggol, Mehman, Nakhalkhchala, Hajigabul), where research was carried out. Samples of needle larvae in the lakes and streams to study species composition and quantities were collected through a narrow cackle and syringe made from gas material # 20. In order to collect samples from deep zones, a shovel and a Petersen type 2.025 m<sup>2</sup> bottom lifting device were used for sampling. The collection of needle larvae found among plants was carried out by washing the plants in special containers. The laboratory also determined the species composition, abundance, and biomass of conifer larvae per unit area. The depths of the lakes (Aggol, Mehman, Nakhalkhchala, Hajigabul), the nature of the soil and the species composition of higher water plants were also investigated. Water temperature, transparency, oxygen regime, active reaction (pH) were studied, and 70% alcohol or 4% formalin solution was used to dissolve the materials. The amount of oxygen in the water of the lakes and ponds that we studied was determined by an oximeter, the active reaction (pH) of the water was determined by litmus paper, and the transparency was determined using the Secchi disk. The book by A. N. Popova “Fauna of Larvae (Odonata)” and Internet sources were used to determine the species composition and number of larvae.

Table 1. - Species composition and distribution of *Inneca* larvae (odonata, larvae) in reservoirs around the Kura river in 2012/17

№	Reservoirs around the Kura river Types	Aggol	Mehman	Nakhalkhchala	Hajigabul	Orphan Kur	Karaoglan	Karhun	Marzli
1.	2.	3.	4.	5.	6.	7.	8.	9.	10.
	<b>Type: Arthropoda</b>								
	<b>Classify: Insecta</b>								
	<b>Group: Odonata</b>								
	<b>Semi-Group: Zygoptera</b>								
	<b>Familia 1: Agrionidae</b>								
1.	<i>Epallage fatime</i> Charpentier, 1840		+				+		
2.	<i>Agrion virgo</i> Linnaeus, 1758	+		+		+		+	+
	<b>Familia 2. Coenagrionidae</b>								
3.	<i>Lestes viridis</i> Vander, 1875	+	+	+		+		+	
4.	<i>L.barbarus</i> Fabricius, 1798	+			+		+		
5.	<i>L.sponsa</i> Hansemann, 1823	+	+		+		+		
6.	<i>L.dryas</i> Kirby, 1890		+			+		+	+
7.	<i>Sympecma fusca</i> Vander, 1820		+	+	+	+	+	+	+
8.	<i>S.paedisca</i> Brauer, 1877			+	+				
9.	<i>Platycnemis pennipes</i> Pallas, 1771	+	+				+		
10	<i>Ishnura elegans</i> Vander, 1820	+	+	+	+	+	+	+	
11	<i>I.pumilio</i> Charpentier, 1825	+	+		+		+		+
12	<i>Enallagma cyathigerum</i> Charpentier, 1840			+	+			+	+



13	<i>Coenagrion lunulatum</i> Charpentier, 1840	+			+		+		+
14	<i>C.armatum</i> Charpentier, 1840	+		+	+			+	+
15	<i>C.pulchellum</i> Vander, 1825	+		+	+			+	
16	<i>C.puella</i> Linnaeus, 1758	+	+	+	+	+	+	+	+
17	<i>C.mercuriale</i> Charpentier, 1840	+	+	+	+	+	+	+	
18	<i>C.scitulum</i> Rambur, 1842	+	+	+	+	+	+	+	+
19	<i>C.johanssoni</i> Wallengren, 1894	+	+	+	+	+	+	+	+
20	<i>Erythromma lindenu</i> Selys, 1840	+		+	+		+		+
21	<i>E.najas</i> Hansemann, 1823		+	+	+	+	+	+	+
22	<i>E.viridulum</i> Charpentier, 1840		+	+	+		+	+	+
	<b>Semi-Group: Anisoptera</b>								
	<b>Familia 3. Aechnidae</b>								
23	<i>Lindenia tetraphylla</i> Vander, 1825			+	+			+	+
24	<i>Gomphus pulchellus</i> Selys, 1840		+	+			+		+
25	<i>G.vilgatissimus</i> Linnaeus, 1758			+		+			
26	<i>Ophiogomphus cecilia</i> Fourcroy, 1785					+		+	
27	<i>Aeshna juncea</i> Linnaeus, 1758		+	+		+		+	+
28	<i>A.affinis</i> Vander, 1820	+		+	+		+		
29	<i>A.grandis</i> Linnaeus, 1758	+			+			+	
30	<i>A.cyanea</i> Müller, 1764	+			+		+		
31	<i>A.viridis</i> Eversman, 1836	+				+			
32	<i>Anax imperator</i> Leach, 1815	+		+	+		+	+	+
33	<i>A.parthenope</i> Selys, 1839				+				+
	<b>Familia 4. Cardulegasteridae</b>								
34	<i>Cordulegaster sp.</i>	+		+		+	+		
	<b>Familia 5. Libellulidae</b>								
35	<i>Cordulia sp.</i>	+	+			+		+	
36	<i>Somatochlora arctica</i> Zetterstedt, 1840						+		
37	<i>Orthetrum brunneum</i> Fonscolombe, 1837	+		+	+		+		+
38	<i>O.cancellatum</i> Linnaeus, 1758		+				+		
39	<i>O.albistylum</i> Selys, 1848		+			+			
40	<i>Libellula depressa</i> Linnaeus, 1758	+	+	+	+	+	+	+	+
41	<i>L.quadrimaculata</i> Linnaeus, 1758		+				+		
42	<i>L.fulva</i> Müller, 1764		+		+			+	
43	<i>Crocothemis erythraea</i> Brulle, 1832			+	+		+		
44	<i>Sympetrum danae</i> Sulzer, 1776				+			+	
45	<i>S.flaveolum</i> Linnaeus, 1758	+			+		+		
46	<i>S.depressiusculum</i> Selys, 1841				+			+	
47	<i>S.vulgatum</i> Linnaeus, 1758	+	+		+	+	+	+	+
48	<i>S.striolatum</i> Charpentier, 1840	+		+	+		+		
49	<i>S.sanguineum</i> Müller, 1764	+			+				+
50	<i>S.meridionale</i> Selys, 1841	+		+	+	+		+	+
	<b>Total</b>	<b>30</b>	<b>23</b>	<b>27</b>	<b>34</b>	<b>20</b>	<b>29</b>	<b>27</b>	<b>23</b>

The article provides information on the species composition (33 species), the distribution and characteristic types of larvae that developed in 4 ponds of important fishing importance that formed around the Kura River. Seven of the recorded species (*S. fusca*, *I. elegans*, *C. puella*, *C. scitulum*, *C. johanssoni*, *L. depressa*, *S. vulgatum*) were found in all ponds, five species (*A. virgo*, *E. najas*, *E. viridulum*, *A. juncea*, *A. imperator*) in four ponds, six species (*L. viridis*, *E. cyathigerum*, *C. lindeni*, *G. pulchellum*, *O. brunneum*, *S. meridionale*) in three of the ponds, seven species (*L. barbarus*, *L. sonsa*, *I. pumilio*, *C. lunulatum*, *C. armatum*, *C. mercuriale*, *Cordulegaster sp.*) in two ponds, eight species (*O. cecilia*, *A. affinis*, *A. grandis*, *A. cyanea*, *Cordulia sp.*, *S. arctica*, *C. erythraea*, *S. depressiusculum*) were found only in one of the pond, one after another. Five species (*C. lunulatum*, *C. johanssoni*, *E. lindeni*, *Cordulia sp.*, *S. arctica*) were found during the researching which were first presented for the fauna of Azerbaijan.

### 3. CONCLUSION

The article provides information of the results of 2012-2017 researching on the species composition and reproduction of *Inneca* larvae (odonata), fauna and forming of ponds and lakes around in the Kura river.

### LITERATURE:

1. 1. Agamaliyev F. G, Aliyev A. R. and b. High school textbook "Hydrobiology". Baku, p. 447 - 455.
2. Bogachev A. V. Otryady strekozy –*Odanata* / A. V. Bogachev// V kn: Zhivotnykh mir Azerbaydzhana. İzv. AN Azerb. SSR, Baku, 1951, s. 275-278.
3. Jadin V. I. Methods for the study of Donna fauna waterways and ecological valleys. W v. "The Presbyterian Valley of the USSR", M-L, 1956, ed, p. 226-273.
4. Popova A. N. The larva streak fauna of the USSR. Ad-USSR, M- L., 1953, p.236.
5. Reproduction of the water pipelines of the Azerbaijan SSR. Search Elm, Baku, 1981, p.108.
6. 6. Əliyev A. R, Əliyev R. A, Quliyeva S. A. Naxalxçala gölünün iynəcə sürfələrinin (odonata) növ tərkibi və miqdarca inkişafı. Azərbaycan Zooloqlar Cəmiyyətinin əsərləri. Bakı, 2014, cild 6, № 2.

# CAPITAL STRUCTURE OPTIMIZATION IN CONDITIONS OF THE SMALL AND MEDIUM-SIZED ENTERPRISES

**Juraj Cug**

*University of Zilina, Faculty of Operation and Economics of Transport and Communication  
Department of Economics, Univerzitna 8215/1, 010 26 Zilina, Slovakia  
juraj.cug@fpedas.uniza.sk*

## **ABSTRACT**

*Capital structure optimization is a key aspect to ensure the success of infrastructure financing. Demand in capital structure optimization in infrastructure projects has been growing rapidly. What is the appropriate capital structure an enterprise should adopt? What financing strategies can minimize its cost of capital? Which factors influence the growth of the company's financial risk? These are key issues in the financing decision-making of an enterprise. This paper reviews such capital composition theories as M-M theorem. The paper is elaborated on a theoretical level and accentuates the approach of Modigliani and Miller, which is described in detail.*

**Keywords:** *capital, capital structure, optimization, tax shield, equity, loan*

## **1. INTRODUCTION**

Shareholders or owners pursue certain goals by their behavior. In the past, the primary goal of the company was profit, more precisely its maximization in the short term, without a time dimension and without taking into account the impact of risk. The basic indicator was therefore the total profit of the company, and later profitability indicators. These indicators were based on historical values of profit, most often accounting profit, and were static variables.

However, the previous approach is already obsolete and we are currently working with more complex models of financial management of the company, which have as their main goal to maximize the market value of the company (shareholder value). The specific goal of the company determined in this way was obtained in the method of discounted cash flows (DCF - Discounted Cash Flow) (Olah, et al. 2019) (Bartosova & Kral, 2016).

Both approaches maximizing profit and maximizing the market value of a company, however, have a common denominator. In both cases, it is about maximizing the difference between the effect obtained from the business activity (income or revenues) and the consumption of inputs into the business activity (expenses or costs). In general, there are three options to maximize this balance:

1. revenue maximization (revenues at constant costs)
2. minimization of expenses with constant revenues
3. a combination of the two previous options

In today's global, highly competitive world, the use of the first option is considerably limited. Logically, companies, unlike in the past, have started to deal with the second option (management and optimization of costs or expenses) of the company. A relatively significant component of business costs is the cost of capital (sources of cover) used by the enterprise. Without sufficient "amount" of capital, an enterprise can not only function, but also create. For each investment project, for each development action, it is desirable to raise sufficient capital at the lowest possible price, taking into account the level of uncertainty and risk and, last but not least, the maturity of that capital. Unlike in previous years, when businesses increased their profits and market value mainly through revenue growth, as market demand clearly outstripped supply, the situation has changed dramatically in recent years, and in a tough competitive environment, businesses have become more costly, analyzing, to reduce them. This seems even more convoluted in the context of the financial crisis, when the purchasing power of the

population is falling sharply, while demand and capital costs are rising. Businesses are therefore starting to deal more intensively with the amount of capital needed, its resources, but especially its prices. They began to focus more intensively on issues and study their capital structure. Over the last 50 years, several theories of capital structure have emerged and are accepted, which give financial managers recommendations that should be respected when deciding on the optimal structure of these resources. However, a more detailed analysis of theoretical knowledge raises a number of problems and ambiguities in this context, as the conclusions of individual theories are often antagonistic. Furthermore, the conclusions of individual theories may not be valid universally, because their recommendations are conditioned by the fulfillment of certain assumptions, which may be hypothetical and relatively "distant" from reality. Last but not least, the vast majority of these theories originated in the Anglo-Saxon environment and empirical verification of their validity also took place in the conditions of Anglo-Saxon economic systems. This fact evokes the question of whether it is possible to apply the theories to companies in a different economic environment, in the Slovak Republic, which clearly differs in social, legal, but especially economic conditions (Boot & Thakor, 2011) (Shkodra, 2019) (Jakoubek & Brabenec, 2012). The conclusions and recommendations of individual theories of capital structure must therefore be subjected to thorough empirical testing in the specific conditions of individual economic systems using simple but also more sophisticated mathematical-statistical methods and procedures to decide whether the conclusions of the theory of capital structure apply or not. On the basis of the facts thus established, subsequently formulate conclusions and recommendations resulting from individual theories of the capital structure of an enterprise for the specific conditions of a given economic system, industry, branch, etc. From a theoretical point of view, the application of the conclusions of individual theories of the capital structure of the company in the Slovak Republic is also complicated by the fact that there is no special publication that would allow the study of individual theories without the need to collect and analyze a relatively large number of professional and scientific articles, articles and monographs (Belas, et al. 2018).

## **2. LITERATURE REVIEW**

There is no clear definition in the world of corporate finance. It depends on the discretion and needs of the user of the financial information to which definition he will agree and which he will consider relevant and most suitable and useful for himself. According to Valach (1999) the financial structure of a company is the structure of the company's capital from which its assets are financed. It is captured by the liabilities of the balance sheet (from a static point of view, at a certain point in time). From a dynamic point of view, the financial structure of the company shows the structure of the increase in corporate capital, from which the increase in assets is financed (eg increase in current assets, fixed assets, etc.). The capital structure of a company captures the structure of corporate capital, from which its fixed assets and the permanent part of current assets are financed. It is therefore a structure of long-term capital of the company. The capital structure is therefore only part of its financial structure. Vlachynsky (1999) states that financial structure is a broader term. It expresses the structure of total capital used to finance assets. The capital structure is characterized as a structure of long-term capital that finances the company's long-term assets (its fixed assets and the fixed assets of current assets). Compared to the financial structure, it is narrower by resources financing short-term current assets of the company. Both categories can be judged from a static or dynamic point of view. From a static point of view, it is a structure of capital covering the assets of an enterprise at some point. It is recorded on the liabilities side of the balance sheet. From a dynamic point of view, it is the structure of capital that finances the increase in corporate assets over a period. The basic source of finance is cash flow from its assets. If the company is financed solely by ordinary shares, all these cash flows belong to the shareholders. When both debt and equity are issued, cash flows

are split into two streams: a safe stream that is directed to bondholders and a more risky one that is directed to shareholders. Mixtures of various securities of a company are called capital structure. Choosing a capital structure is essentially a marketing problem. A company can issue dozens of different securities in numerous combinations, but is trying to find a combination that maximizes its overall market value (Brealey & Myers, 2000). Criticisms of this approach to the capital structure also appear in the literature and are justified by the following arguments. They observe the inaccuracy of such a definition of the capital structure in two aspects:

1. The capital structure shall comprise not only capital in the form of securities issued but also long-term bank loans, retained earnings, long-term liabilities to suppliers and the like.
2. In the capital structure, it is not all the securities with which the company comes into contact but only the securities issued by the company; purchased securities are a natural part of the company's assets.

### 3. METHODOLOGY AND DATA

The capital structure of a company or project reflects the structure of the financial resources used to finance a business or project. The resources (funds) that keep the business running can be generated internally - by the business itself or externally. In order to increase capital arising from the external environment, an enterprise has two options: either to issue shares or to "raise" debt (to issue bonds, to draw credit, etc.). Most of the effort in the process of long-term financial decision-making is focused on determining the optimal capital structure of the company and on the decision on the optimal ratio of debt to equity (Appiah, et al. 2019).

We can state with all seriousness that the question of choosing the optimal capital structure of a company has not yet been satisfactorily answered. There are several approaches to optimization of the capital structure in the literature. (Frank & Goyal, 2009), (Elsas, et al. 2014), (Modigliani & Miller, 1958), (Modigliani & Miller, 1963) (Valaskova, et al. 2019) (Kral, et al. 2019). We follow eight basic approaches to optimal capital structure:

1. The classical theory of capital structure
2. Traditional theory of capital structure (U curve theory) (D. Durand).
3. The theory of capital structure of M&M (F., Modigliani, M. H. Miller)
4. Compromise theory of capital structure (R. A. Brealey, S. C. Myers)
5. Theory of Hierarchical Order (S.C. Myers and N.S. Majluf).
6. Signaling theory of capital structure (S. Ross)
7. The theory of capital structure of trade-offs (M.C. Jensen, W.H. Meckling, Y. Amihud, B. Lev, B. Giner, C. Revert)
8. Free cash flow theory (M.C. Jensen).

We will deal in detail with the third approach to the optimization of the capital structure, the approach of Modigliani and Miller.

### 4. RESULTS AND DISCUSSION

Modigliani and Miller's theory, developed in 1958-65, had a major impact on the further development of the optimal capital structure theory. Modigliani and Miller presented completely different conclusions in their work. Under certain assumptions, the average cost of capital, as well as the market value of a firm, are independent of the capital structure. This fundamental claim is referred to as M-M claim I. The authors make this conclusion if the following conditions are met:

1. Existence of perfect capital markets: absence of transaction costs when buying and selling securities; no investor has a material influence on the price of securities; all investors have the same information; all investors can borrow money at the same interest.

2. Absence of income taxes.
3. Absence of bankruptcy costs.
4. Homogeneous expectation of future profits - this means that all investors expect the same amount of profit before tax and interest.

According to M-M, if the above assumptions are met, the debt costs are still the same, the cost of equity increases and the average cost of capital remains the same. The market value of the company does not change as a result of the constant average cost of capital. The amount of the debt thus has no impact on the market value of the company. Graphically, M-M claim I can be illustrated as follows. (Fig. 1.)

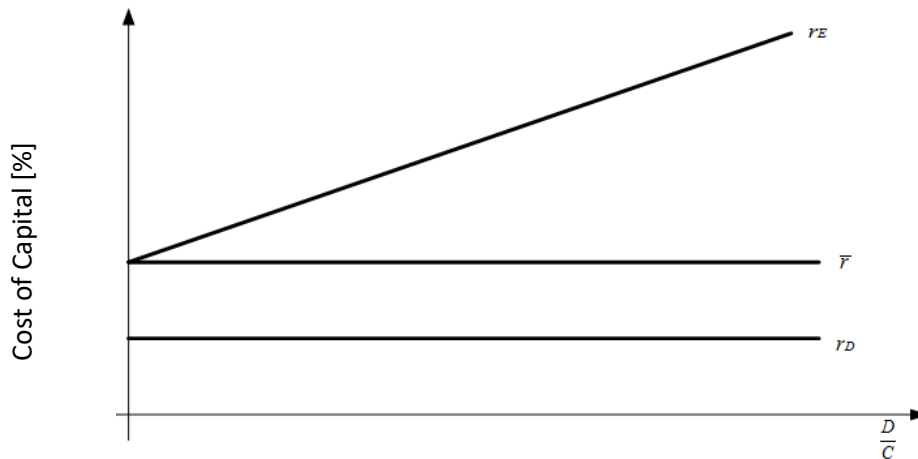

Figure 1. M-M model I

where :

- D - debt amount
- C - total capital
- $r_D$  - debt costs
- $r_E$  - cost of equity
- $\bar{r}$  - average cost of capital

The authors justified this claim by claiming that the return on cheaper debt is immediately replaced by the rising cost of equity.

M-M's argument I was not accepted in theory or in business practice. The main reason was abstracting from two important factors:

- taxes on profits
- the cost of financial distress

Modigliani and Miller themselves later recognized the impact of income taxes on the company's capital structure. As a result, their original claim, M-M I, was changed to M-M II, where they stated that the cost of capital as a result of an interest-bearing tax shield was declining and the market value of the company was thus increasing. The authors argue that debt interest does not affect the enterprise in full but is reduced by an interest tax shield. It follows from claim II that it would be most advantageous for an undertaking to benefit from the maximum level of indebtedness. This conclusion can be illustrated graphically as follows (Fig. 2).

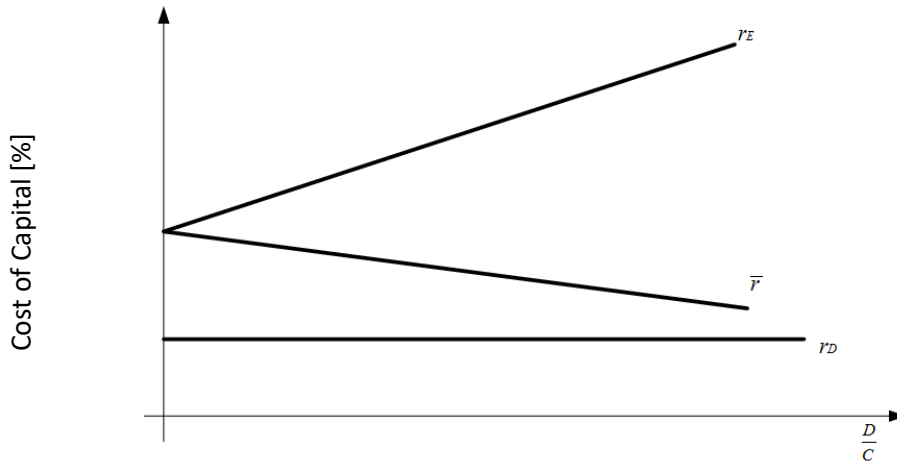

Figure 2. M-M claim II - declining cost of capital

where:

- D - debt amount
- C - total capital
- $r_D$  - debt costs
- $r_E$  - cost of equity
- $\bar{r}$  - average cost of capital

In the next stage of the examination, the costs of financial distress (bankruptcy costs) were included in the examination of the cost of capital in addition to the interest tax shield. The inclusion of these costs of financial distress, which, according to foreign estimates make amount to 15-20% of the value of the assets, significantly influenced the development of the theory of optimizing the capital structure of the company. Thanks to the cost of financial distress, the financial risk of the company increases. This risk increases to some extent as the company's debt increases. This increases the cost of debt financing, as the positive impact of the interest tax shield is more than offset by the negative cost of financial distress. This results in an increase in the total cost of capital (from a certain point) and also in a decrease in the market value of the company. This conclusion is the theoretical justification of the 'U' curve of the development of the cost of capital. The described effects can be represented graphically as follows (Fig. 3).

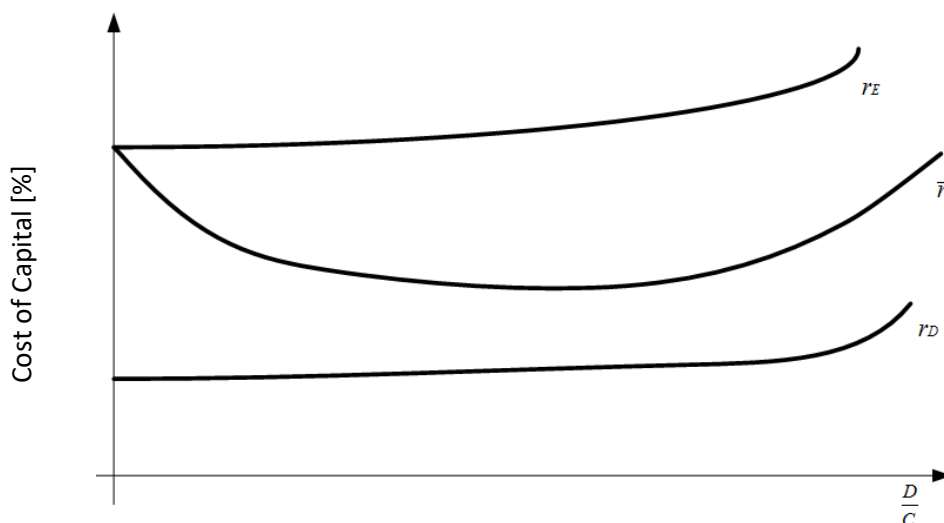

Figure 3. Average cost of capital after taking into account the cost of financial distress and the interest tax shield

where:

- D - debt amount
- C - total capital
- $r_D$  - debt costs
- $r_E$  - cost of equity
- $\bar{r}$  - average cost of capital

It is evident that, taking into account the cost of financial distress, the extremely indebted capital structure is an incorrect choice and at least an approximate optimal share of debt in the total capital of the enterprise should be sought.

## 5. CONCLUSION

One of the most important and central questions of financial management of a company is the creation of an optimal capital structure. One of the most prominent aspects are the assessment of the ratio of equity to debt. Own and external resources are significantly regulated by funding rules and theoretical basis of individual approaches to capital structure optimization. In this article we dealt with the approach of Modigliani and Miller. The inclusion of costs of financial distress significantly influenced the development of the theory of optimization of the capital structure of the company.

## ACKNOWLEDGEMENT

*The paper is an output of the science project VEGA 1/0210/19 Research of innovative attributes of quantitative and qualitative fundamentals of the opportunistic earnings modelling.*

## LITERATURE:

1. Appiah, M. K., Possumah, B. T., Ahmat, N., and Sanusi, N. A (2019). Small and medium enterprise's internal resources and investment decisions in Ghana: The resource-based approach, *Economics and Sociology*, 12 (3).
2. Bartosova, V., Kral, P. (2016). A Methodological Framework of Financial Analysis Results Objectification in the Slovak Republic, 3rd International Conference on Business and Economics (BE-ci), MALAYSIA, European Proceedings of Social and Behavioural Sciences, 17, 189-197.
3. Belas, J., Gavurova, B. and Toth, P. (2018). Impact of selected characteristics of SMES on the capital structure. *Journal of Business Economics and Management*, 19 (4), 592-608.
4. Boot, W. A., Thakor, A. V. (2011). Managerial Autonomy, Allocation of Control Rights, and Optimal Capital Structure. *Review of Financial Studies*, 24 (10), 3434 – 3485.
5. Brealey, R. A., Myers, S. C. (2000). *Theory and practice of corporate finance*, Prague: Computer Press, 1064, 324.
6. Elsas, R., Flannery, M. J., and Garfinkel, J.A. (2014). Financing Major Investments: Information about Capital Structure Decisions. *Review of Finance*, 18, 1341 – 1386.
7. Frank, M. Z., Goyal, V. K. (2009). Capital Structure Decisions: Which Factors are Reliably Important? *Journal of Finance*, 39, 1067—1089
8. Jakoubek, J., Brabenec, T. (2012). Aspects of intangible property valuation in intra-group financial management. *Managing and Modelling of Financial Risks – 6th International Scientific Conference Proceedings*, Ostrava, Czech Republic. 277-289.
9. Kral, P., Valjaskova, V., and Janoskova, K. (2019). Quantitative approach to project portfolio management: proposal for Slovak companies. *Oeconomia Copernicana*, 10 (4), 797-814.
10. Modigliani, F. F., Miller, M. H. (1958). **The cost of capital, corporation finance and the theory of investment.** *American Economic Review*, 48, 267-297.



11. Modigliani, F. F., Miller, M. H. (1963). **Corporation income taxes and the cost of capital: A correction**, *American Economic Review*
12. Olah, J., Kovacs, S., Virglerova, Z., Lakner, Z. and Popp, J. (2019). Analysis and Comparison of Economic and Financial Risk Sources in SMEs of the Visegrad Group and Serbia, *Sustainability*, 11(7), 1853.
13. Shkodra, J. (2019). Financial performance of microfinance institutions in Kosovo, *Journal of International Studies*, 12 (3).
14. Valach, J. (1999). *Financial management*. Prague: Ekopress, 324, 128.
15. Valaskova, K. et al. (2019). How capital structure affects business valuation: A case study of Slovakia. *Central European Business Review*, 8 (3), 1-17.
16. Vlachynsky, K. et al. (1999) *Corporate Finance*. Bratislava: Suvaha, 460, 187.

# INFLUENCE OF TIME MANAGEMENT ON PERFORMANCE OF MANAGERS

**Darina Chlebkova**

*University of Zilina, Slovakia*

*darina.chlebkova@fpedas.uniza.sk*

## **ABSTRACT**

*We live in a time when we encounter a sense of lack of time in private and professional life. In fact, the problem is not the lack of time, we all have the same time, but problem is in its incorrect planning and use this time. This often leads to the fact that we have to stay longer at work or take work at home, at the expense of time for family or our hobbies. The use of time management will help managers achieve better organization of their work and the results of its use will be reflected in the improvement of the quality and efficiency of their work. For managers, time management is an essential prerequisite for the systematic and effective coordination of management activities. Management is the process of managing and directing all or part of a business through the deployment and manipulation of resources. The manager who carries out the activities of this process is in the role of informant and head of the subordinates as well as the general public, therefore it is reasonable to organize time him in a number of activities to be carried out. Time management is a certain time-assessment behavior aimed at self-awareness of time-use, which assists in assuming tasks and responsibilities that fall within the manager's abilities and roles. Their use in practice increases not only the quality and efficiency of managers' work, but also reduces stress and improves work and personal life. The aim of the paper is to point out the possibilities of using time management tools and methods on the performance of managers. Their use in practice increases not only the quality and efficiency of managers' work, but also reduces stress and improves work and personal life*

**Keywords:** *stress, time management, performance, quality of work, work efficiency*

## **1.INTRODUCTION**

We used to say sometime: I have little time, I don't have much time left, I wasted my time, I didn't save time, my free time ..... But let's ask the question: what is time? Only a person deals with time, only he suffers from a lack of time, better use of time, etc. The problem probably occurred when one began to measure time and allocate to individual activities. Time for work rest, fun, thinking and suddenly he found that he had little time, his task schedule was badly misaligned for individual activities and found that he could not buy it, save it, stop it, multiply, because time simply passes. Our life is defined by time and the quality of time spent determines the quality of our life. Time management involves various methods of time management, which one we perceive as a limited resource. The goal is to gain control over time. We use various methods and techniques used in various activities. These are those that can be used within the organization and in companies, as well as those that are used to plan personal life. The problem, in fact, is not a lack of time, we all have the same one, but its improper planning, use and management. However, in reality we do not control the time, it flows the same, but we can control our approach to the time we have to use it. By using time efficiently through a set of time management tools and approaches, we can achieve a more balanced and fulfilling life. Time management - become the masters of your time.

## 2.LITERATURE REVIEW

There are many authors writing about the time management, and each of other comes a definition. LJ Seiwert (1995) defined time management as: “Consistent, targeted use of best practices in daily practice that help us lead and organize ourselves and individual areas of our lives so that we make optimal and meaningful use of the time available to us. Brodský (2014), Stacho and Stachová (2017) also agree on the idea that it is a matter of management and organization. The authors Roberts (1998), Knoblauch et al (2012), Heppell (2012), Uhlig (2008), Pacovský (2008) deal with time management in their publications. Bride (2011) reminds us that it is not possible to manage time, but it is possible to control how we use time. In her publication, Bindra (2015) focuses on time management and effective planning, time analysis, setting priorities and goals. Farrell (2017) states that time management is an essential part of leadership, and managers must determine which time-saving methods are most effective for them. Reunanen (2015) says that time is the most important resource for leaders, so they should manage it properly. In his article, Pugh (2012) deals with time management, planning, setting priorities and increasing work efficiency. According to several authors, time management developed gradually, without the appearance of an author who would have the right to speak of himself as the founder of this concept. The development of time management is most often divided into 4 generations, while in their definition the authors agree and talk about the first generation as a paper method, where it is solved mainly what needs to be done. The second generation adds to the question of WHAT to do and the question of WHEN it is necessary to do it. The third generation extends the previous two by the question of HOW to perform the task and the fourth generation focuses mainly on man, self-knowledge and management, paying the most attention to the fourth generation Brodský (2014), Štěpaník (2008) in *The Art of Dealing with People 3*, Pacovský (2006) v *Man and time: time management IV. generations*. Human capital is often seen as the only resource that can be constantly developed and, in the long run, can be described as key to raising the level of organizations. Today's society needs to invest more and more in lifelong learning due to rapid changes in the living and business environment. (Stacho, 2019), especially with regard to management and managers. Today, managers are one of the most influential social groups. (Sułkowski, 2019). Due to the growing scale of the challenges faced by the manager, effective business management is impossible without making quick and informed decisions. (Borisova, 2019). The complexity of information processing and the need to establish continuous information flows at all levels of management require the use of modern information technologies. (Borisova, 2019). All managers who want to lead their employees and achieve defined goals of the company should use new and modern management methods and techniques in their managerial practice. (Kmecova,2019).

## 3.METHODS

### Time planning

Successfully used time consists of a series of selected goals that have been successfully completed. Mastering the art of good use of time means deftly and gracefully moving between the present moment and the future of our lives. ”(Majerčák, 2006). Majerčák (2006) divides manager time into three main types:

1. Time for the boss - at this time the tasks assigned to the manager by the superior staff are performed. These tasks would not have to be performed if the manager did not have a boss.

However, it is better to spend time on these tasks than to spend much more time fighting a dissatisfied boss.

2. Time for the system - the manager at this time deals with tasks arising from the organizational structure. This time is devoted to the administrative and similar requirements of his colleagues and partners, who are part of each organization. These include meetings, appointments and phone calls that need time.
3. Time for yourself - this is the time that the manager uses according to himself, this time being the most important time. It is possible to divide it into time for subordinates and freely usable time. With free time, the manager has the opportunity to focus on the tasks he chooses, whether it is leadership, planning, organizing, or creative activity. In case the manager starts to run out of time, this time is the first to be lost.

As part of planning, it is necessary to determine the time horizons in which we will plan and how detailed we will plan them. We can divide time into regularly recurring activities that last about the same amount of time, knowing what and when to do. The second group is the scheduled time. We do not find regularly recurring activities in this group. We decide on the use of planned time on the basis of goals and tasks and in certain horizons, but at the same time its use is influenced by external influences that may represent the goals of other people.

### **Setting goals and priorities.**

You can't decide what you want to deal with today if you don't know where you want to go tomorrow. Any plan to make better use of time depends on clarifying your goals. "(Hindle, 2002)

Šuler (1995) says that correctly set goals are the key to life dreams, while giving us the opportunity to proceed effectively in planning and motivating ourselves and our surroundings. When setting goals, he recommends following the following procedure: Create a vision, Speak. Write down your goals. Transform goals into tasks. Act.

The relationship between goal and performance is strongest when we have the determination to achieve our goals. For goals to be effective, feedback is needed to reveal progress on the goals.

### **3.1. Time planning techniques**

Effective planning means that we must be able to reconcile different time frames. The importance of long-term and short-term goals depends on the nature of the work, but according to Brodský it is recommended to plan in four time frames:

1. **Daily planning:** a daily plan should be created at the end of the previous day so that we have enough time to think about tasks and activities and to identify with the plan,
2. **Weekly planning:** before planning, it is necessary to set a day when the plan for the following week will be prepared regularly. The weekly plan is continuously updated in conjunction with the daily plan, but does not change,
3. **Quarterly planning:** deals with larger time periods that focus on projects and development phases. It helps to meet deadlines to meet commitments, set priorities.
4. **Annual planning:** previous planning experience is important in preparing an annual plan, taking into account situations that may arise during the year and, of course, tasks that recur regularly or are planned by someone else.

### **ABC analysis**

ABC analysis is one of the simple but effective tools used in setting priorities. It is a method in which the examined areas are divided into key, important and insignificant matters. (Jíra,

Humlerová, 2013). In the ABC analysis, it is necessary to focus on the correct setting of priorities and the correct sequence of tasks during the day.

Therefore, we should not focus only on the tasks included in group A, while forgetting about the tasks belonging to group C. Seiwert (1991) recommends using ABC analysis as follows:

1. schedule 1 or 2 A tasks per day (approximately 3 hours),
2. determine other 2 - 3 B - tasks (approximately 1 hour),
3. Allocate the remaining time for C-tasks (about 45 min).

### **Pareto rule**

This is the principle of 80:20, when often 20% of properly organized time will bring 80% of results. (Seiwert, 1990) According to Pareto's principle, we should choose two or three tasks, assign them the time needed to complete them, and focus on completing them.

### **Eisenhower's principle**

The basic idea of the principle is a systematic approach to activities based on priorities. Before tasks are categorized, they must be thoroughly analyzed on the basis of two dimensions, namely the importance of the task and the urgency of the task. By categorizing tasks according to the above dimensions, we get an overview of what, when and how to do based on the division of tasks into: important and urgent, important and non-urgent, unimportant, but urgent, unimportant and non-urgent.

## **3.2. Methods of time management**

They represent a comprehensive approach to the management of work and personal life:

### **GTD - Getting Things Done**

This method Getting Things Done (by David Allen) - GTD translates to “everything will be handled.” This method is a comprehensive approach to managing work and personal life, creating space and providing a structure for developing creativity, strategy, and concentration in five steps. The five steps of the GTD method:

1. Collect - record all ideas, tasks, responsibilities, whether it is a work or personal sphere.
2. Process - we take everything we have recorded and ask ourselves whether it is possible to do so.
3. Organize - put it where it belongs. We will create lists for the relevant categories and assign individual tasks there.
4. Update- Check the list as often as needed to make it clear what needs to be done next. Perform a weekly check and update the to-do list to clear your mind.
5. Execute - simply execute. Use your system to take the appropriate steps.

### **Method S.R.O.R.U.Z.O**

The initial letters represent the names of the individual tasks that the method includes:

**1. Summary of tasks** - when summarizing tasks, it is necessary to include in the plan all tasks, meetings and activities that await us on a given day. It is also important to think about routine tasks and unresolved tasks from previous days.

**2. Estimating time for individual activities** - when estimating time for individual tasks, it is appropriate to build on previous experience, if we know how long it took us to complete the same task in the past. We also count the time for breaks and for moving from place to place.

**3. Spare time** - with the help of spare time we will prevent unexpected tasks from disrupting our schedule of the day. The recommended time of reserve time is 20% - 50% of the time of a normal working day. This time reserve will help us to manage the little things that can significantly affect the daily schedule.

**4. Determination of priorities** - from the list of summarized tasks we choose the activities that have the highest priority for the given day. We perform the highest priority tasks when we are most efficient.

**5. Back check** - at the end of the working day there is a back check, we will find out whether the plan of the day was realistically compiled. If we still have unresolved tasks, we will postpone them to the next day, or we will add newly agreed meetings. (Knoblauch et al., 2012).

### **3.3. Tools and aids of time management**

Tools and aids that facilitate time management can be divided into classic paper or more modern related to electronic devices. Each of them has its advantages and disadvantages. These are related to their processing, clarity or reuse, in the case of electronic there is a risk of software or hardware error.

Those that can be written or electronic include:

- Diaries,
- and mind maps.

The second group consists of those that are tied to some electronic medium (PC, mobile phone, tablet, etc.). These would include:

- Microsoft Outlook,
- Google Calendar
- Wunderlist,
- Tomato technology,
- Forest application,
- Remember to milk.

### **3.4. Delegation**

It is actually a process of decentralization of activities, ie the transfer of goals, tasks, competencies and responsibilities from hierarchically highest positions to the lowest. Delegation is used to remove excessive workload and assign specific tasks to people who have sufficient expertise in the field. (Andronic, Dumitrascu, 2018). The purpose of the delegation is to reach the final status assigned to the employee. The goal should be specified to the employee as concretely, as clearly as possible and so that the output of his work is measurable. No employee can perform tasks effectively unless his or her supervisor specifies his or her goals accurately.

What is appropriate to delegate:

- Routine work, including responsibilities and authority.
- Tasks that others perform better and faster.
- As part of the development of subordinate skills, delegate tasks that will provide space for the acquisition of new knowledge.
- Tasks that revive routine work to avoid stereotyping.
- Decisions in which the subordinate knows the details better than the superior. (Šuler 2009)

What is not appropriate to delegate:

- It is not possible to delegate tasks containing confidential information.
- Tasks that must be solved by themselves.
- Tasks for which subordinates do not have sufficient training.
- Tasks that are part of our responsibilities, even if they are uncomfortable for us.
- Poorly defined tasks in which the employee could lose too much time. (Šuler 2009)

### **3.5. Procrastination**

The word, a term that has been used quite often lately, its loose definition of meaning is "put off until tomorrow." It is a repeated postponement of tasks and responsibilities, while the individual is engaged in something different than he should be engaged in. In the literature, we encounter several types of procrastination. Selective procrastination, where only some tasks and responsibilities are postponed more often. During the total procrastination, various tasks related to work and personal life are postponed. Active procrastination does not bring unpleasant feelings (guilt, remorse), because it is a rational decision, because the tasks are completed in the allotted time. Passive procrastination brings unpleasant feelings that can lead to mental problems. We can speak of procrastination as a rational skill in the case when an individual correctly determines what he can put off until later and thus gain time for other tasks. (Nývlová, 2014) states in her article that procrastination represents the failure to perform activities within a specified time, or the postponement of activities until the end of the list of tasks that we intend to perform.

## **4. DISCUSSION**

In a manufacturing company with 160 employees, we analyzed the use of time management methods and tools. The company is a subsidiary of a multinational company. The company operates in Slovakia in the automotive industry. The target group were managers at the middle management level. The task was to find out the use of methods, techniques and tools of time management in their work, as well as their dealing with procrastination and other factors that affect their performance. We performed the analysis in a structured interview. There were four managers, three of whom were men and one woman. The age range was from 32 to 51 years. We found that two use Diary and Outlook, two use paper utilities: a desk calendar and notebooks. Regarding time management methods. One uses the ABC method and one stated that he does not use any method, but as the interview showed, he unknowingly uses Eisenhower's principle. Regarding procrastination, one said he did not practice it at work and three said yes, but as a result of a change in the tasks assigned by their superiors. Three of the managers delegate some of the tasks to subordinates and one does not.

The delegation was due to other again random tasks on the part of superiors, only one saw the reason in the wrong description of his work. Other factors that affect their work were mainly those that resulted from the work environment. All of them, together with other administrative staff, were in one large room (16 people in total), where they were interrupted by phone calls,

visitors were a disturbing element, poorly deployed desks, no climate, and one mentioned numerous meetings.

## 5. CONCLUSION

Time management is one of the key factors in the efficiency of human labor. As we found out in Slovakia, although we cannot draw general conclusions from one case study, simpler techniques and aids in the work of middle management still prevail. Of course, the type of activity that managers perform as well as the industry in which the company operates, its size, age structure of employees, etc. also play an important role in the use of time management. Paradoxically, more than the use of time management, performance was affected by poor working conditions.

## LITEATURE

1. Andronic, O. G., Dumintrascu, D. (2018). *The Misconceived Delegation of Responsibility*. IN: *Procedia - Social and Behavioral Sciences – SIM 2017/14th International Symposium in Management*. [s. l.]: Elsevier Ltd. Vol. 238, p. 408 – 413. ISSN 1877-0428. DOI: 10.1016/j.sbspro.2018.04.018.
2. Borisova, V.V., Demkina, O.V., Mikhailova, A.V., Zielenski, R.(2019). *The Enterprise Management System: Evaluating The Use Of Information Technoogy And Information Ssystems, at Polish Journal Of Managemnt Studies*.Vol.20No.1 ( str, 103-117)
3. Brodský, J. (2014). *Time management*. Praha: Ústav práva a právní vědy, o.p.s. 101 s. ISBN 978-80-905247-9-8.
4. Heppel, M. (2012). *How to get an hour a day* Praha: Grada Publishing, a. s. 192 s. ISBN 978-80-247-4155-0.
5. Hindle, T. (2002). *Time planning*. Bratislava: Slovart, spol s. r. o. ISBN 80-7145-649-7.
6. Jíra, A., Humlerová V., Humler S. *Time-management*. České Budějovice: Chance in Nature - Local Action Group, 2013. ISBN 978-80-7394-408-7.
7. Kmecová, I. ( 2019) *The Processes Of Managing Human Resources And Using Management Methods And Techniques*. In *Management Practice: Ekonomicko manažérske spektrum*, volume XII, Issue I, str 44-54, ISSN 1337-0839
8. Knoblauch, J., et al. (2012). *Time management*. *Mejte svuj cas pod kontrolou*. Praha: GradaPublishing. 208 s. ISBN 978-80-247-4431-5.
9. MAJERČÁK, P. (2006). *Current view on the classification of managers and the perception of time from their point of view*.In: *Manažment v teórii a praxi* [online]. Košice: Katedra manažmentu, Podnikovohospodárska fakulta so sídlom v Košiciach, Ekonomická univerzita v Bratislave, roč, 2., číslo 2, s. 29 - 35. [citované 4. februára 209]. ISSN 1336-7137. Dostupné na internete: <<http://casopisy.euke.sk/mtp/clanky/2-2006/majercak.pdf>>.
10. Nývlová, V. (2014). *Soft skills - Time management for job seekers*. Praha: Vysoká škola chemicko-technická. 35 s.
11. Pacovský, P. (2006). *Man and time*. Praha: Grada Publishing, a. s. 260 s. ISBN 80-2471701-8.
12. Reunanen, T.(2015). *Human factor in time management*. In: *Procedia manufacturing- 6th International Conference on Applied Human Factors and Ergonomics (AHFE 2015) and the Affiliated Conferences, AHFE 2015*. [s. l.]: Elsevier B. V. Vol. 3, p. 709 – 716. ISSN 2351-9789. DOI: 10.1016/j.promfg.2015.07.311.



13. Roberts, J. (1998). *Time management: your questions and answers*. Great Britain: Redwood Books. ISBN 0 85660 328 7.
14. Stacho, Z., Stachová, K., & Raišiene, A. G. (2019). *Changes in approach to employee development in organizations on a regional scale*. Journal of International Studies, 12(2), 299-308. doi:10.14254/2071-8330.2019/12-2/19
15. Sułkowski, L. (2019). *On bullshit management – the critical management studies perspective*. Economics and Sociology, 12(1), 302-312. doi: 10.14254/2071789X.2019/12-1/18
16. Seiwert, L. J. (1991). *Race against time*. Bratislava: Alfa. 64 s. ISBN 80-05-00923-2.
17. Štěpaník, J. (2008). *The art of dealing with people 3*. Praha: Grada Publishing, a. s. 168 s. ISBN 978-80-247-1527-8.
18. Šuler, O. (2009). *100 key management techniques*, Computers Press, ISBN 978-80-251-2173-3
19. Uhlig, B. (2008). *Time management- Become the master of your time*. Havlíčkův Brod, a. s. 160 s. ISBN 978-80-247-2661

## ECONOMIC FREEDOM AND BUSINESS PROFITABILITY

**Rita de Cassia de Lima Diniz**

*University Presbiteriana Mackenzie, Brazil  
Consolação str. 930, São Paulo  
limadinizr@outlook.com*

**Henrique Formigoni**

*University Presbiteriana Mackenzie, Brazil  
Consolação str. 930, São Paulo  
hformigoni@mackenzie.br*

**Liliane Cristina Segura**

*University Presbiteriana Mackenzie, Brazil  
Consolação str. 930, São Paulo  
lilianecristina.segura@mackenzie.br*

### **ABSTRACT**

*This research investigated the relationship between corporate profitability and economic freedom index. The population studied were companies from several countries that are part of the Capital IQ database. Four years were analyzed (from 2014 to 2018) and the final sample consisted of 10,000 companies, out of a total of 50,000 observations. From the sample, there was a regression with the index: ROE, ROA, EBITDA and net margin, which showed the positive relationship between the profitability index and economic freedom. Therefore, organizations influence society, and seek the one that provides added value and sustainable profit. Thus, profitability is an intrinsic variable to economic freedom, since the ability to generate profit is associated with the regulation of the country to which the entity is subjected. Freedom is the principal means and end in itself for economic progress through the free condition of people, services, and goods. The exchange of commerce and services is increasingly present in everyday life. This State-regulated exchange influences the expenditure of citizens. Despite government regulation, which is necessary to maintain society, economic freedom is also of main importance to expenditure and development of the local economies, that is, the liberal State is an agreement of wills between its agents in order to reach mutual interests with development for both.*

**Keywords:** *Economic freedom, Profitability, Regulation*

### **1. INTRODUCTION**

According to the International Investor (2017), the Heritage Foundation divides the fundamental pillars of economic freedom into four categories: Rule of Law: Property Rights, Integrity of Government, and Legal Effectiveness. Of these categories, the one that most contributes to Brazil's failure is precisely the size of the government. The International Investor (2017) points out that the tax burden is up to 27.5% for individuals and, adding up all transactions, it reaches 34% for legal entities. In total, the Brazilian tax burden reaches, on average, 32.8%. Government spending amounts to almost 40% of GDP. The deficit in public accounts has averaged 6.4% of GDP over the past three years (2014, 2015 and 2016). Public debt is equivalent to 73% of GDP in 2017.

According to Friedman (2002, p.16):

Economic organizations play a dual role in promoting a free society. First, as a component of freedom in the broad sense, economic freedom is an end in itself. Economic freedom is also an indispensable means of achieving political freedom.

The latest economic freedom rankings around the world, developed by the Heritage Foundation in the 2017 Economic Freedom Index, demonstrate that citizens who live in countries that practice economic freedom are better off than those who live in countries that don't. The data show a strong correlation between economic freedom and a variety of positive outcomes, including economic prosperity and low poverty rates. Countries with greater economic freedom have a higher per capita income and a lower incidence of hunger.

Thus, economic freedom is linked to social events present in our daily lives. The State implements norms as a regulator of social relations, however laws and norms determined by it have an arbitrary character and, consequently, interfere in competition between companies, in addition to affecting their profitability. Thus, the competitive environment between organizations is influenced by the State. In terms of tax complexity, according to the TMF Group (2017), Brazil is the second most complex country in the world in terms of tax and accounting compliance for doing business. TMF Group (2017) analyzed the necessary procedures for a company to remain regularized, in 94 countries, and released the so-called Financial Complexity Index 2017. According to the data, comply with tax laws in the three spheres of the Brazilian government - federal, state and municipal -; keeping up with obligations and avoiding being caught up in an irrelevant error - but one that can be costly - are the daily challenges of Brazilian businessmen. The ten countries with the greatest financial complexity in the world are: 1. Turkey; 2. Brazil; 3. Italy; 4. Greece; 5. Vietnam; 6. Colombia; 7. China; 8. Belgium; 9. Argentina; and 10. India.

Dani, Santos and Hein (2000) carried out a research aiming to analyze the relationship between the ranking of economic freedom and the logistical performance of the countries belonging to the G20. They collected the data from the Economic Freedom and World Bank base, in the period from 2011 to 2015. They concluded that developed countries have economic freedom and greater logistical performance. They found a positive correlation between the economic freedom rankings and the logistical performance for countries in the period from 2013 to 2015.

## **1.2. Research Question**

In view of the above, the following research question was formulated “what is the relationship between the profitability of companies and the ranking of economic freedom?”

## **1.3. Specific objectives**

This research has as specific objectives:

- a) identify the profitability of companies in the various countries that are part of the Capital IQ database;
- b) to identify the ranking of economic freedom of the countries in which the headquarters of the companies are installed;
- c) Analyze the profitability behavior of companies in different countries, considering the ranking of economic freedom.

## **1.4. Study Hypothesis**

The research hypothesis of this study is that there is a positive relationship between the company's profitability and the ranking of economic freedom in the country where it is installed.

### 1.5. Justification

The greater the degree of economic freedom in a country, the more the organizations present in it will have the power of choices and possibilities before the market, after all:

From the moment that there are control mechanisms on behalf of the State, the level of freedom in the economy decreases, and agents are restricted in relation to their choices, interfering in the degree of efficiency desired for a given action "(CARVALHO , BAGAGI and PEGORARO, 2018, p. 20).

It is noteworthy that, despite the role of mediator, the State fosters the process of socialization and sociability of citizens and, according to Mauriti (2018), the “new liberalism” presents a character of social justice with a focus on redistributive mechanisms. Mauriti (2018) reports that the State must provide social institutions that act as a driving force for the realization of individual potentialities. Therefore, it is understood that individuals are also part of organizations and are part of the production chain (which aims at profit), that is, the influence of arbitrary economic freedom influenced by a State is present from the daily life of a citizen to the profitability of organizations. Thus, the analysis of the relationship between the levels of economic freedom of a country in the profitability of the organizations present in this country is relevant and important, because when understanding the degree of State interference in a nation, the possibility of development in this country is identified.

## 2. THEORETICAL REFERENCE

Organizations, despite their social importance and the capacity to transform the environment in which they operate, seek profitability, that is, profitability through the means of production, as a result of their commercial activities. Liberalism, as a political and economic doctrine, emerges in feudalism, contributing to its overthrow and to the rise of capitalism. Gradually, liberalism became the ideology of the new (bourgeois) class and the new mode of production, capitalism (PEREIRA; 2004). Capitalism provides commercial exchange between nations and organizations spread around the world, that is, the factors of production are interconnected, fostering the globalization of the production belt. In addition, the media brought the continents together quickly and effectively, which contributed to world trade. In this way, commercial transactions are carried out through mobile applications. With a simple touch on the screen it is possible to close deals at any time, something until then considered futuristic and distant from the reality of everyone in the last century, that is, the “world is smaller” and quick and instant communication enables new forms of profitability organizations. However, potentiating talents and identifying new forms of profitability has become a major challenge and a competitive differential, since in the face of several business options and easy access to data and information, the consumer has become more critical. In this way, companies must identify places that provide a production chain with quality and mainly profitability in a sustainable way that adds value. Therefore, it is understood that organizations aim for profit, through their activities, and for that they use capital, labor, raw material and, above all, strategic business management, to enhance the competitive advantages in relation to their competitors. Using profitability indexes of companies listed on the BOVESPA, in the cyclical consumption sector, more precisely in the sub-sector of fabrics, clothing and footwear, Vieira et al. (2011) studied the ROA, ROI and ROE, based on the financial statements of the companies, and found that the return provided by the investments made caused several fluctuations in the clothing segment. Some companies had higher indicators in the first period of the analysis carried out, and then they had a reduction; while others showed a certain evolution at each analysis period. On the other hand, in the footwear segment, sometimes a company has a higher and sometimes a lower profitability index. However, in the accessories segment, it is noticed that there is no evolution

in relation to its indexes. Braga; Nossa and Marques (2004) state that the joint profitability of own and third-party resources is measured by the rate of return on total assets (ROA - Return on assets), measured by Net Income divided by Total Assets. This indicator explains whether the profitability of the total resources invested in the asset was more influenced by the net margin or the turnover of the total investment. The measure of economic success in relation to the owners' capital is provided by the rate of return on equity (ROE - Return on equity), which is measured by the Net Income divided by the Shareholders' Equity.

Vieira et al (2011) and Braga; Nossa and Marques (2004) calculated the ROA, ROI and ROE indices as follows:

ROA = Net Income / Total Assets

ROI = Net Operating Income / Investments

ROE = Net Income / Equity

According to Silva, Lima, Costa and Sant'Anna (2015), financial leverage allows to accelerate or decelerate the growth of a company. In addition, an organization's development is influenced through profitability and asset management. In this way, investors can analyze the expected return on equity and the organization's ability to manage its assets. However, the historical and economic moment, as well as economic freedom, fosters the resourcefulness of profitability.

According to Barros, Menezes, Colauto and Teodoro (2014), financial leverage is calculated according to the following:

AF = Total Liabilities / Total Assets

Bussler (2016) states that profitability is the expected return on an investment, discounting costs, tariffs and inflation, that is, it is a measure of evaluation of the performance of an investment, resulting in a positive or negative variation in the wealth of an investor, commonly represented in percentage form.

Pimentel and Lima (2011) argue that profitability and liquidity appear alternately as conditions for the survival of the company or as conditioned by the strategy implemented by the company, and emphasize that high amounts employed in current assets, in an idle manner, foster additional costs for their maintenance, thus reducing the company's profitability.

Wernke and Lembeck (2004) showed possible applications of the concept of contribution margin to evaluate the performance of commercial segments, turning more specifically to companies operating in the merchandise distribution business. They exemplified situations in which the contribution margin can serve as a support tool for sales managers to ascertain the profitability of products, merchandise lines, sales territories, distribution channels, customers and salespeople. Finally, they emphasized the projection of operating results based on the total contribution and its benefits.

## **2.1. Economic freedom**

Bender Filho, Sonaglio and Zamberlan (2013) quantified the differences in the level of economic growth in countries with differentiated policies and institutions, such as developed and developing countries, and their relationship with the degree of economic freedom in the period between 2000 and 2007. For therefore, they used as a technique of analysis a model with panel data. The results obtained indicated that the degree of economic freedom, in the five areas analyzed, influenced economic growth. Among the results, they highlighted the influence of international trade, an area that showed a positive relationship when analyzed with developing

countries, as well as a negative relationship with developed countries, which was justified by institutional aspects related to subsidies and other barriers to foreign trade. The defense of the minimum state is influenced by the self-regulated existence of the market through an “invisible hand. However, the presence of the State is represented to ensure social rights and possible economic regulation in the event of financial crises. (Cenci; Bedin; Fischer, 2011). Thus, it is understood that, although the State has an arbitrary character in commercial relations, “the invisible hand”, a term created by Adam Smith, leads us to understand the self-regulation of the market in the face of economic interests, that is, the degree of A country's economic freedom will foster such self-regulation and, consequently, the profitability of organizations. State intervention in the economy, although not inevitable, is highly likely (BOETTKE; 2014). Liberalism and its ideals aroused in Europe through liberal revolutions echo today in our daily lives. According to Cotrim (2009), the flags of liberal struggles occurred in different countries in Europe in the 19th century and highlighted the lesser interference of the state in the economy of a country and economic activities would be in charge of private initiative. The Liberal State model was a historical landmark of the French Revolution designed to face the absolutism in force throughout the Lower Middle Ages, through the application of the principle of non-intervention by the State in private relations (*laissez-faire, laissez-passer*) (BALTAZAR , 2004). Given the arguments listed according to Cenci, Bedin and Fischer (2011), liberalism should not be understood through a homogeneous ideology, since its conceptualization is influenced in the historical moment that is analyzed, as well as the type of interpretation that does. Therefore, a liberal state is not necessarily democratic, just as a democratic government will not necessarily be liberal, since the liberal state is not a concession, but the result of an agreement of wills. According to Friedman (2002), despite the freedom of the market, the presence of the State must not be eliminated, as the government is essential to determine rules and apply and inspect rules. The great advantage of the market is to encourage diversity through wide competition, an attribute that provides economic freedom. Baltazar (2004) points out that freedom is the conjecture for deliberating for what is best. Therefore, the agent-state will be able to promote the social realization of economic freedom, while preserving the public interest. Santos and Toledo Filho (2012) identified the level of importance that public spending represents in the general classification of the degree of economic freedom of countries worldwide. The study consisted of a descriptive, documentary type research with a quantitative approach to the data. The sample was composed of 167 countries classified in the Index of Economic Freedom of 2010. As analysis and interpretation techniques of the results, the principal component analysis and the informational entropy technique were used. The results indicated that among the ten components established by the final ranking of the degree of economic freedom of the sample countries, public spending was considered the fourth determining factor necessary to justify the classification of countries in the Index of Economic Freedom. Spending was also the fourth factor with the greatest weight of information to establish the degree of economic freedom in the countries investigated. From these findings, it was concluded that the control of public spending is essential for the nation's growth, especially when it is in balance with revenues, as observed by the moderate positive relationship between these two variables. The market economy is the product of a long evolutionary process. It is the result of man's efforts to adjust his action, in the best possible way, to the given conditions of an environment that he cannot modify, in which the reiteration of individual acts of exchange gives rise to the market, as the division evolves in a society based on private property. Such exchanges can only be made if each party attributes greater value to what he receives than to what he renounces (MISES, 2011). Boettke (2014) states that the good society is one whose governance framework allows individuals to gain the gains of social cooperation under the division of labor, and thus experience the benefits of material progress through individual freedom, that is, a society constituted by free and responsible individuals, who participate and

operate in a market economy based on the profit and loss system, who have the opportunity to prosper or not to prosper within it. Free will is a driving force for the market, since everyone acts on their own, but everyone's actions seek to satisfy both their own needs and those of others. In acting, everyone serves their fellow citizens. On the other hand, everyone is served by them. Each is both a means and an end; an ultimate end in itself and a means for other people to achieve their own ends (MISES, 2011).

## 2.2. Methodological Procedures

This research has a descriptive character and quantitative method. According to Gil (1999), the objective of descriptive research is to list the characteristics of a given population and, from this, establish relationships between variables. Mattar (2014) points out that descriptive research studies processes inherent in a population through certain characteristics or behaviors, in order to discover or verify the existence of a relationship between variables. The population consists of the companies and respective countries where they are based, present in Capital IQ. The sample is composed of 10,000 companies that presented the necessary data for the research, totaling 50,000 observations in the period from 2014 to 2018. The data related to profitability indicators were collected from the companies' financial statements, and the countries' economic freedom ranking was obtained through the Heritage Foundation.

## 3. ANALYSIS OF RESULTS

Table 1 shows the descriptive statistics of the geographic regions where the sample companies are located.

**Table 1: Geographic regions of the countries analyzed**

<b>Geographic Region</b>	<b>N. Obs.</b>	<b>%</b>	<b>% Cum.</b>
Africa / Middle East	1,83	3,66	3,66
Asia / Pacific	27,505	55,01	58,67
Europe	8,935	17,87	76,54
Latin America and the Caribbean	1,275	2,55	79,09
United States and Canada	10,425	20,85	99,94
Not identified	30	0,06	100,00

Source: Research data.

Table 1 shows that the Asia / Pacific region is the most representative of the sample, which corresponds to 5,501 companies (= 27,505 observations), followed by the United States and Canada with 2,085 companies (= 10,425 observations). The region with the least representation in the sample is Latin America and the Caribbean with 255 companies (= 1,275 observations). Table 2 shows the descriptive statistics of the countries where the sample companies are located.

**Table 2: Distribution of sample countries**

<b>Country</b>	<b>N Obs.</b>	<b>%</b>
China	9710	19.42
United States	8185	16.37
Japan	6480	12.96
Taiwan	2480	4.96
Canada	2240	4.48
South Korea	1935	3.87

Hong Kong	1930	386	3.86
United Kingdom	1910	382	3.82
France	1585	317	3.17
Australia	1580	316	3.16
India	1110	222	2.22
Sweden	945	189	1.89
Germany	820	164	1.64
Israel	700	140	1.40
Singapore	690	138	1.38
Philippines	545	109	1.09
Italy	540	108	1.08
Brazil	495	99	0.99
Switzerland	470	94	0.94
Malaysia	340	68	0.68
Thailand	335	67	0.67
Spain	295	59	0.59
Belgium	290	58	0.58
Netherlands	285	57	0.57
Denmark	265	53	0.53
Finland	265	53	0.53
Ireland	255	51	0.51
Mexico	240	48	0.48
South Africa	220	44	0.44
Saudi Arabia	200	40	0.40
Norway	195	39	0.39
Greece	170	34	0.34
New Zealand	155	31	0.31
Cayman Islands	140	28	0.28
Morocco	125	25	0.25
Peru	125	25	0.25
Poland	115	23	0.23
Bermuda	110	22	0.22
Luxembourg	110	22	0.22
Chile	105	21	0.21
United Arab Emirates	85	17	0.17
Austria	80	16	0.16
Egypt	80	16	0.16
Portugal	80	16	0.16
Peru	70	14	0.14
Bahrain	65	13	0.13
Pakistan	60	12	0.12
Bangladesh	50	10	0.10
Croatia	50	10	0.10
Kuwait	50	10	0.10
Vietnam	50	10	0.10



Colombia	45	9 0.09
Qatar	40	8 0.08
Argentina	35	7 0.07
Iceland	35	7 0.07
Tunisia	35	7 0.07
Malta	30	6 0.06
Nigeria	30	6 0.06
Bulgaria	25	5 0.05
Oman	25	5 0.05
Estonia	20	4 0.04
Jersey	20	4 0.04
Mauritius	20	4 0.04
Russia	20	4 0.04
Cyprus	15	3 0.03
Jordan	15	3 0.03
Monaco	15	3 0.03
Romania	15	3 0.03
British Virgin Islands	10	2 0.02
Czech Republic	10	2 0.02
Guernsey	10	2 0.02
Hungary	10	2 0.02
Indonesia	10	2 0.02
Kazakhstan	10	2 0.02
Macao	10	2 0.02
Sri Lanka	10	2 0.02
Azerbaijan	5	1 0.01
Barbados	5	1 0.01
Channel Islands	5	1 0.01
Costa Rica	5	1 0.01
Curacao	5	1 0.01
Gibraltar	5	1 0.01
Kenya	5	1 0.01
Kyrgyzstan	5	1 0.01
Lebanon	5	1 0.01
Panama	5	1 0.01
Papua New Guinea	5	1 0.01
Senegal	5	1 0.01
Serbia	5	1 0.01
Uruguay	5	1 0.01

Source: Research data.

Note that China has the largest number of companies (1,942 = 9,710 observations) followed by the United States (1,637 = 8,185 observations) and Japan (1,296 = 6,480 observations). Table 3 presents the descriptive statistics of the indicators used in this study.

**Table 3: Indexes Used**

<b>Variable</b>	<b>N. Obs.</b>	<b>Average</b>	<b>Standard deviation.</b>	<b>Mín.</b>	<b>Máx.</b>
Size	47,067	7300352	2019485	2263844	1223035
Total Indebtedness	47,067	0,2168988	0.199653	0	0.891591
Working capital	47,051	0,2829978	3719678	0.1644809	2583832
Net margin	46,074	0,9100653	4865075	0.0018973	4301587
ROE	47,632	0,2671312	0.6485775	0.0027798	5090692
ROA	47,067	0,1138544	0.2141208	0.0013158	1546798
Economic Freedom Index	49,65	7,443384	0.7200514	4493011	9003802

Source: Research data.

After eliminating the blank data, the variable ROE presented 47,632 observations, followed by the variables Size, Total Debt and ROA with 47,067 observations; Working Capital with 47,051 observations; and Net Margin with 46,074 observations. It is observed that the companies in the sample have, on average, low total debt (22%) and high net margin (91%).

Table 4 presents the results of the regression performed for the profitability indices.

**Table 4: Regression to profitability indexes**

<b>Variables</b>	<b>ROE</b>	<b>ROA</b>	<b>Net Margin</b>	<b>Ebitda margin</b>
Economic Freedom Index	0.071*** (0.006)	0.029*** (0.002)	0.607*** (0.063)	0.383*** (0.043)
Working capital	-0.016*** (0.001)	-0.006*** (0.000)	0.134*** (0.007)	0.076*** (0.005)
Total Indebtedness	0.799*** (0.019)	0.147*** (0.006)	0.606*** (0.145)	0.262*** (0.096)
Size	-0.132*** (0.002)	-0.065*** (0.001)	-0.537*** (0.022)	-0.345*** (0.015)
Year 2014	-0.087*** (0.007)	-0.039*** (0.002)	-0.274*** (0.043)	-0.192*** (0.028)
Year 2015	-0.015** (0.007)	-0.008*** (0.002)	- (0.040)	-0.046* (0.026)
Year 2016	-0.048*** (0.007)	-0.022*** (0.002)	-0.090** (0.040)	-0.067** (0.026)
Year 2017	-0.036*** (0.007)	-0.015*** (0.002)	- (0.039)	- (0.026)
Year 2018	-	-	-	-

Source: Research data.

It is observed that the sign of the ROA, ROE, Net Margin, Ebitda and Total Indebtedness indicators are positive, which means that the higher the economic freedom index, the higher the indicator. However, working capital and company size show a negative sign, meaning that the higher the economic freedom index, the lower the indicator. The total debt will also be higher.

#### 4. CONCLUSION

This study contributes to the literature on economic freedom through a quantitative investigation of profitability indicators in companies listed in the Capital IQ database. For the execution of the study, a sample of 10,000 companies was used during the period from 2014 to 2018, totaling 50,000 observations. A linear regression was performed with the indexes: ROE, ROA, EBITDA and Net Margin, having as control variables: Working Capital, Total Debt, Size and Year. The results showed a positive relationship between the companies' profitability and economic freedom indexes in the country where the company is located. It can be seen, therefore, from the main results of this research, that the relationship between the country's economic freedom and the profitability of the companies located in it are related, that is, the greater the country's economic freedom, the greater the potential profitability generator for the companies installed there.

#### LITERATURE:

1. BALTAZAR, SHALOM MOREIRA (2004) A liberdade econômica e o interesse público como novos paradigmas do Estado. Disponível: <https://jus.com.br/artigos/5877>. Acesso: Julho/2018.
2. BENDER FILHO, R.; SONAGLIO, C. M.; ZAMBERLAN, C. O. (2013). Instituições, liberdade econômica e crescimento: uma análise de países desenvolvidos e em desenvolvimento. Pesquisa & Debate. Revista do Programa de Estudos Pós-Graduados em Economia Política da PUC-SP, v. 24, n 2, p.244, 2013.
3. BRAGA, ROBERTO; NOSSA, VALCEMIRO; MARQUES, JOSÉ AUGUSTO VEIGA DA COSTA. (2004). Uma proposta para a análise integrada da liquidez e rentabilidade das empresas. Revista Contabilidade e Finanças, v.15, jun., 2004.
4. CENCI, ANA; BEDIN, GABRIEL DE LIMA; FISCHER, SANTI RICARDO (2011). Do Liberalismo ao Intervencionismo: O Estado como Protagonista da (Des)Regulação Econômica. Constituição, Economia e Desenvolvimento: Revista da Academia Brasileira de Direito Constitucional, v. 3, n. 4, p. 77-97, Jan-Jun., 2011.
5. COTRIM, G. História global Brasil e geral. 8. ed. São Paulo: Saraiva, 2005.
6. DANI, A. C.; SANTOS, C. A.; HEIN, N. (2017). Correlação entre o ranking de liberdade econômica e de desempenho logístico: uma análise multicritério. Contabilometria - Brazilian Journal of Quantitative Methods Applied to Accounting, 4(2), p. 1-17, jul.-dez., 2017.
7. FRIEDMAN, M. (2002). Capitalismo e Liberdade. 2. ed. São Paulo: LTC, 2002.
8. GIL, Antônio Carlos. Métodos e Técnicas de Pesquisa Social. 5. ed. São Paulo: Atlas, 1999.
9. HERITAGE FOUNDATION. (2019). Economic Freedom: Policies for Lasting Progress and Prosperity. Defining Economic Freedom. Disponível em: <https://www.heritage.org/index/book/chapter-2>. Acesso em Agosto/2019.
10. \_\_\_\_\_. Index of Economic Freedom: trade and prosperity at risk. (2018). Disponível em: <https://www.heritage.org/international-economies/report/2017-index-economic-freedom-tradeand-prosperity-risk>. Acesso em Abril/2018.
11. INVESTIDOR INTERNACIONAL. (2007). Ranking de Liberdade Econômica de 2017. Elaborado por Fundação Heritage. Disponível em <http://www.investidorinternacional.com/2017/02/19/liberdade-economica-2017/>. Acesso em: Abril/2018.
12. MARIUTTI, EDUARDO BARROS. (2018). Liberdade, Justiça, Concorrência e Mercado: as tensões no pensamento liberal contemporâneo. Disponível em: <https://www8.eco.unicamp.br/Publicacoes/>. Acesso: Abril/2018.
13. MATTAR, Fauze Najib. Pesquisa de marketing: metodologia, planejamento, execução e análise. 7. ed. Rio de Janeiro: Elsevier, 2014.

14. MISES, LUDWING VON. (2018). Mercado, praxeologia, lucros e prejuízos. Disponível em: <https://www.mises.org.br/Article.aspx?id=1107>. Acesso: Setembro/2018.
15. PEREIRA, WILLIAM EUFRÁSIO NUNES (2004). Do Estado Liberal ao Neoliberal. Interface - Revista do Centro de Ciências Sociais Aplicadas, v. 1, n. 1, p. 11-24, Janeiro-Junho, 2004.
16. ROANJALI, A. A. G.; SALVIANO, V. A. M.; BITENCOURT, A. C. V.; SOUZA, A. A.; LOUZADA, L. C. (2018). Evidências empíricas do efeito da carga tributária sobre o desempenho financeiro de empresas brasileiras do setor de consumo. Disponível em: [https://www.researchgate.net/profile/Vagner\\_Marques2/publication/313853774\\_evidencias\\_e\\_mpiricas\\_do\\_efeito\\_da\\_carga\\_tributaria\\_sobre\\_o\\_desempenho\\_financeiro\\_de\\_empresas\\_br\\_asileiras/links/58ab5827aca27206d9bd11c6/](https://www.researchgate.net/profile/Vagner_Marques2/publication/313853774_evidencias_e_mpiricas_do_efeito_da_carga_tributaria_sobre_o_desempenho_financeiro_de_empresas_br_asileiras/links/58ab5827aca27206d9bd11c6/). Acesso Mar/2018.
17. SANTOS, P. A.; TOLEDO FILHO, J. (2012). Participação dos gastos públicos no grau de liberdade econômica: análise dos países em âmbito mundial. Economia Global e Gestão, (17)2, Set., 2012.
18. SILVA, D. A.; NELSON, A. V. M.; SILVA, M. A. R. (2018). Do desenvolvimento como crescimento econômico ao desenvolvimento como liberdade: A evolução de um conceito. Desenvolvimento em Questão, v. 16, n. 42, 2018.
19. SILVA, E. H. D. R.; LIMA, E. P.; COSTA; S. E. G.; SANT'ANNA; Â. M. O. (2015). Análise comparativa de rentabilidade: um estudo sobre o Índice de Sustentabilidade Empresarial. Gestão da Produção, v. 22, n. 4, p. 743-754, 2015.
20. TMF GROUP. (2018). The Financial Complexity Index 2017. Disponível em: <https://www.tmfgroup.com/en/campaigns/mea/financial-complexity-index-2017/>. Acesso em: 03/04/2018.
21. VIEIRA, C. B. H. A.; VERDE, I. O. L.; BEZERRA, R. L.; RODRIGUES, P. N.; ISMAEL, V. S. (2011). Índices de rentabilidade: um estudo sobre os indicadores ROA, ROI e ROE de empresas do subsetor de tecidos, calçados e vestuários listadas na BOVESPA. VIII Convibra Administração – Congresso Virtual Brasileiro de Administração, Dez/2011.
22. WERNKE, R.; LEMBECK, M. (2004). Análise de rentabilidade dos segmentos de mercado de empresa distribuidora de mercadorias. Revista Contabilidade & Finanças, (15)35, May/Aug. 2004.

## **ENABLING OPEN DATA PARADIGM FOR BUSINESS IMPROVEMENT**

**Larisa Hrustek**

*University of Zagreb, Faculty of Organization and Informatics,  
Pavlinska 2, Varaždin, Croatia  
lhrustek@foi.unizg.hr*

**Martina Tomicic Furjan**

*University of Zagreb  
Faculty of Organization and Informatics, Pavlinska 2, Varaždin, Croatia  
mtomicic@foi.unizg.hr*

**Igor Pihir**

*University of Zagreb  
Faculty of Organization and Informatics, Pavlinska 2, Varaždin, Croatia  
ipihir@foi.unizg.hr*

### **ABSTRACT**

*Technological and business changes as a result of digital transformation are introduced in new business models. Available data has become the core of interactions in digital business due to its unlimited amount. The digital world has shaped a culture of interaction based on data, and digital transformation leaders are expected to create innovative products and services, as well as increase data readiness to create and share information and deliver seamless services. Open data, as a subset of all data considered, is still a relatively unexploited area, as shown by the analysis of relevant research. The role of governments and organizations is crucial in creating open data as well as using and implementing it and gaining benefits. This paper will define open data and analyse its characteristics. Based on that insights, a process model of enabling open data paradigm will be presented and some recommendations for its use in business improvement initiatives will be given.*

**Keywords:** *Open Data, digital transformation, digital society, open government*

### **1. INTRODUCTION**

Ten or more years ago, digitalization focused on the transition from analogue to digital services to increase efficiency by service providers. Over the last few years, digital transformation and everything it brings has gone a step further, and the goals of service providers are redesigning and remodeling services from the ground up in order to meet the changing and demanding needs of users. Digital transformation is a change of policies, processes and services to create a simpler user experience for citizens and workers. In the center of these changes are the internal and external users of digital services involved in digital transformation efforts (Mrgel et al., 2018). In other words, digital transformation is changing the service delivery system and moving from traditionally closed to an open system, which can be based on open data. System theory states that this will affect business, management, and feedback within the system (Janssen, Charalabidis & Zuiderwijk, 2012) and ultimately lead to customer-supplied service. One of the aspects of digital transformation is the creation of open data to improve the provision of digital services (Mrgel et al., 2018), which would increase the potential benefit to society (Poldrack & Gorgolewski, 2014) such as greater transparency, enhanced participation and cooperation of users and the use of useful and important data for making decisions (Zuiderwijk & Janssen, 2014).

Most open data research highlights the effects they have on the system. Potential they hide is unknown and has no boundaries, so it can be said that open data is a relatively unexplored and unused area (Janssen, Charalabidis & Zuidervijk, 2012). Open data is publicly available, free of charge and free to reuse for a variety of purposes, with the ability to discover hidden or unnoticeable value in it, aimed at achieving the goal by providing service improvements.

This paper aims to explore basic concepts of open data research, creation and use and to give some recommendation for improvements. First, the concept and characteristics of open data will be defined, as well as its connection with open science and open system, and the role in creating them. Second, based on the review of existing research, a process model will be developed and presented for the open data paradigm, that is, the process of creating open data. Third, recommendations for its use in business improvement initiatives will be presented to support potential creators of open data, as well as already open systems that seek to enhance existing services and knowledge.

The motivation for exploring open data, in particular the creation of open data, is based on the need to publish data that would be widely used, driven by the goals of open systems and open science such as greater citizen involvement, greater transparency, improved decision making, enhanced services and the creation of new services. The developed process model of enabling the open data paradigm can provide support to potential creators in the process through simple guidelines and recommendations which will be given.

## **2. LITERATURE REVIEW**

Open access, open data, open system, open science - the word "open" integrates these terms and denotes freedom of use, reuse and redistribution without restriction, as defined by the Open Knowledge Organization (OKD). OKD began research about open data in 2009 by developing guidelines, tools and applications to promote open data and allow scientists to make most of them (Molloy, 2011).

### **2.1. What is “open”?**

"Open" means something that is accessible and usable. Open access is defined as free access (Molloy, 2011). Open data is defined as the concept according to which data should be accessible to all without restriction, with the possibility of redistribution in any form (Kassen, 2013), easily founding and accessible (Veljković, Bogdanović-Dinić & Stoimenov, 2014) and are produced with public money with no restriction to privacy or confidentiality. It should be emphasized that the word "open" and the term open access are fully included in the explanation of the term open data.

One step beyond open data is open science and open systems. Open science is an advanced concept that includes not only open data but also analysis and methods (Poldrack & Gorgolewski, 2014) applied in knowledge creation. Open data is the foundation on which open science and open systems rest, so creating open data is a crucial process in creating these two phenomena and their values.

Authors	Open data definition
Janssen, Charalabidis & Zuiderwijk, 2012	“...define open data as non-privacy-restricted and non-confidential data which is produced with public money and is made available without any restrictions on its usage or distribution.”
Reichman, Jones & Schildhauer, 2011	“...open data will enhance and accelerate scientific advance, there is also a need for “open science”- where not only data but also analyses and methods are preserved, providing better transparency and reproducibility of results.”
Kassen, 2013	“...Open data is a concept that governmental data should be available to anyone with a possibility of redistribution in any form without any copyright restrictions.”
Veljković, Bogdanović-Dinić, Stoimenov, 2014	“...Open data are governmental data of public interest that are available without any restrictions and that can be easily found and accessed.”
Gurstein, 2011	“...the open data movement in the area of access to public (and other) information is a relatively new but very significant, and potentially powerful, emerging force; to make local, regional and national data (and particularly publicly acquired data) available in a form that allows for direct manipulation using software tools...”

*Table 1: Definition of open data*

Open data is a force that will define much of the revenue for institutions in the near future. Marr states that data will become a strategic tool for survival and prosperity in market (Marr, 2017). It remains for the institutions to get acquainted with and learn about open data and all that it has to offer.

Following, definition of open data is given, in Table 1, as well as key characteristics based on an analysis of the relevant literature, shown in Figure 1.

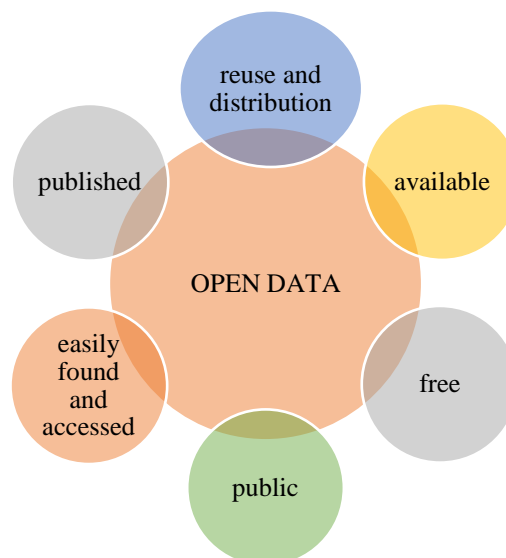

*Figure 1: Open data Characteristics*

Open data are published, free, easy-to-find and easy-to-download for use by anyone, or can be processed through publicly available tools, and later reused or published. These characteristics we highlight, as they show the great potential open data has for its users.

Open data can be used for a variety of purposes and it includes a great range of useful processing capabilities. The results of using open data can bring great value to those who use it.

Digital transformation has brought about a lot of changes and more accessible open data is surely one of them. Open data is made possible through digital technologies, and each user only needs to identify the right one.

## **2.2. Insights into relevant research**

Most researches in the field of open data deal with defining the effects that open data should have on the community. Janssen et al. (2012) explained the advantages and barriers to the impact of the use of open data. Poldrack and Gorgolewski (2014) emphasizes the goal of sharing open data, which is to increase the potential benefit to society by providing greater opportunities for scientific discovery. The benefits of data sharing, such as improved research practices, increased reproducibility and reproducibility, are emphasized. Their research addresses the technological challenges of open data, especially in the field of environmental data, and points out that these are data dispersion, heterogeneity and origin (Poldrack & Gorgolewski, 2014). Zuiderwijk and Janssen (2014) analyzed open data policies and their implementation and impact. The analysis showed that data publishing organizations can contribute to the development of open data policies in terms of their effects and adapt to the changing production, distribution and use of open data.

An open data policy should have a clearly defined culture of influence on the development and effects of open data implementation. In order for an open data and goals policy, or all the benefits of applying data such as economic growth, innovation and transparency, to be realized, it is necessary to develop a culture where disclosure is considered a standard (Zuiderwijk & Janssen, 2014) and the creation of open data is fundamental in the process of this paradigm. Kassen (2013) has developed a framework for evaluating open data projects where the main purpose of the research was to strengthen the potential of open data phenomena at the local level as a platform useful for promoting civic engagement projects and to provide a framework for future testing and hypothesis testing.

Open data initiatives are creating a new enabling environment for creating and promoting enhanced services. In their research, Conradie and S. Chonnei (2014) sought to understand which of the internal processes and how they affect the publication of data. Based on the analysis, information was obtained on how to store data, obtain data and how responsible persons use it for open disclosure.

The promotion of open data and the development of platforms that reduce the cost and difficulty of handling data (Molloy, 2011) is one of the fundamental objectives of open science. Juppl et al. (2014) referred to technologies for describing, publishing and linking data and the importance of user satisfaction in the semantic sense. Veljković et al. (2014) introduced a benchmark method for comparing open data government and its application to the open data perspective or application of data.

All published work mentioned clearly defines the characteristics of open data, the advantages and effects that open data should achieve through the realization of an open system (open government / organizations) and open science is presented as well. Although open data policies seek to clearly define activities and goals of publishing and implementing open data, the process of creating open data is still a challenge for open data creators.



### **3. PROCESS MODEL OF ENABLING OPEN DATA PARADIGM**

This chapter will explain who the creators of open data are and provide an overview of known processes in the field of open data creation. Based on what is known, and with the addition of certain phases and activities, a process model of enabling open data paradigm was created.

#### **3.1. Open Data Creators**

The open data paradigm distinguishes four key roles in the open data enabling process, namely creators (providers), processors, owners and maintainers (Janssen, Charalabidis & Zuiderwijk, 2012). This article will not address each of the roles and their responsibilities and obligations individually (which could be addressed in future research) but it will concentrate only on Open Data Creators. Public authorities, private organizations, scientists and researchers, and the public, have been identified as the creators of open data. Public authorities are among the largest creators and collectors of data in various fields such as traffic, weather, geographical and tourism information, various types of statistics, business data, public sector budget and business performance, all types of policy and policy outputs, and inspection results (food, safety, quality of education, etc.) (Janssen, Charalabidis & Zuiderwijk, 2012). Scientists and researchers become creators of open data through their research work and projects, as well as through publication of scientific papers. Private organizations, by creating their open data, can become open to the market, which can bring them closer to customers, but also, through the retrieval of open data from the users, they can identify their needs and therefore improve business. Ultimately, open data creators are also users of open data, and an open system can be described as an input-output feedback relationship.

#### **3.2. Digital technologies and open data**

Digital technologies and the opportunities they provide play an important role in developing the open data paradigm. The introduction of digital technologies does not change only institutions but enhances current working practices and organizational structures (Janssen, Charalabidis & Zuiderwijk, 2012). Digital technologies are a prerequisite for creating an open data paradigm. Kassen state that publishing data sets as raw materials in a machine-readable format that can then be selectively processed by developers for e-government projects can increase overall cost-effectiveness and transparency. Sharing and distribution of collective knowledge can become more viable as new interactive digital technologies evolve. Digital tools such as online platforms and applications, based on the use of open data, can enable users to influence the decision-making process by providing valuable information and collective intelligence in a more convenient and efficient way. Apart from the fact that technologies are necessary for the creation of open data, various projects that use open data to create applications and platforms for direct user participation are a good example of business practice and the development of innovative solutions tailored to users (Kassen, 2013) as well.

#### **3.3. Processes in open data creation**

The pressure on public and private sector organizations to publish their data has increased because of the assumption that using open data can create wealth by leveraging results in a further business flow, solving complex problems (Janssen, Charalabidis & Zuiderwijk, 2012) or contributing to the development of innovation and science. The motivation for creating open data and all efforts aimed at developing open access areas, systems and open data can be recognized in research that presents the effects this paradigm brings.

Reichman et al. (2011) present the Open Data Initiative (environmental data) and present their mechanisms for potential data providers. They split the whole process into two key processes, namely data acquisition workflow and data analysis workflow. The data is collected and

documented using an acquisition workflow, and then the raw and resulting data products are retrieved and stored in a data archive. Researchers discover and access data and then integrate and process the data in the course of analysis, resulting in derivative data products, visualizations and scientific papers that in turn are archived in the system.

Conradie and Chonnei (2014) investigate the processes involved in the disclosure of data within six public sector organizations in the Netherlands, with the aim of identifying indicators that play a significant role in the release of data to the public. The methods used in this research were workshops, questionnaires and interviews with key persons at different levels of organizations. Important indicators for data disclosure have been found to be the way in which data is stored (distributed / decentralized versus centralized), how data is obtained and how organization use them.

Janssen et al. (2012) emphasized the importance of open data policies that encourage the publication of open data. Open data policies should provide a comprehensive overview of open data activities, objectives and impacts, that is, the enabling role of open data policies is the first and comprehensive step in creating open data.

Public information has a wide variety of characteristics and can vary in aspects such as level of detail, quality, usefulness, intrinsic value and more. The diverse nature of open data suggests that the benefits and barriers of open data may vary depending on the type of data, and also suggests that different data need to be handled in different ways. In conclusion, it is necessary to consider whether, how and what public sector data can be published. It depends on the constraints on the legislative environment, the resources needed, the potential risks of abuse and bias, and the potential value that can be gained from publishing the information (Janssen, Charalabidis & Zuiderwijk, 2012). Based on the above, it is possible to identify which aspects of open data generation should focus activities.

The success of an open data system requires more than simply providing access to data, and they are needed for improving the quality of government information, creating and institutionalizing an open government culture, and providing tools and instruments for using data. This broader perspective should be taken by the open data creators who open the portal to make the data accessible. Infrastructure needed to help users understand data, and institutional measures are needed to ensure public engagement (Janssen, Charalabidis & Zuiderwijk, 2012).

#### **4. PROCESS MODEL FOR ENABLING THE OPEN DATA PARADIGM**

In this chapter, the process model of enabling the open data paradigm is defined. The model, shown in figure 2, is developed as a BPMN process model using Bizagi Modeler.

The first phase in the open data paradigm process model is the discovery data. In this phase, open data creators identify the data that could be of use, or whose publication could generate some value. This activity is based on the idea of the creator, that some data could be used in the future. Creators through the activity of access data come in first touch with raw data, and it is the first impression one gets about data. Activity selection data indicates the extraction of data according to the appropriate attributes. The following is a classification of data that involves organizing the data into appropriate categories so that they can later be used and protected. At the end of this phase, the data is stored.

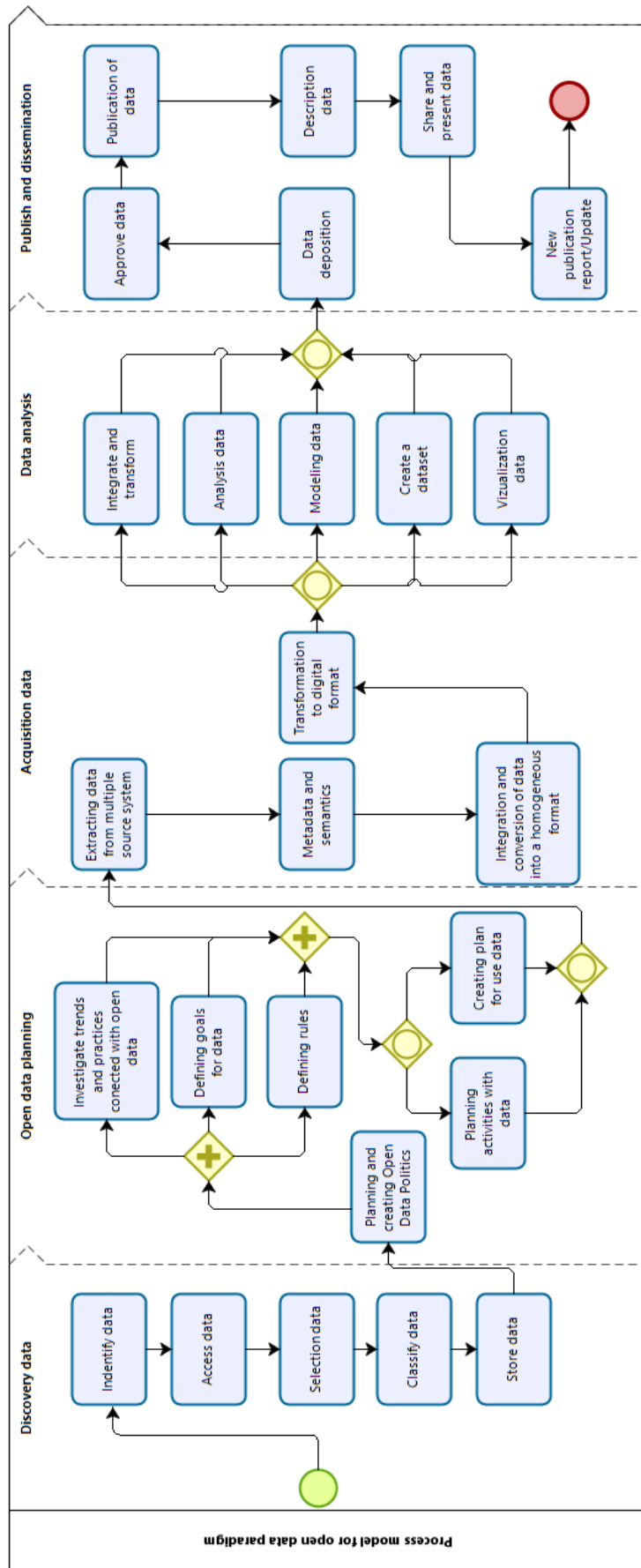

Figure 2: Process model for open data paradigm

The next phase in this process is open data planning, which is the planning and creation of the Open Data Policy. An open-source trend research and practice activity, defining goals and rules for open data, can take place in parallel, ie all three activities at the same time. This is followed by planning open data activities and creating a plan for using open data. These activities take place in parallel or one of them can be run independently. It is at this stage that the basic things are decided, why some data should be made open, what is the purpose of it and how they should be used and after they can be made open.

The phase of acquisition of the data begins by extracting data from multiple sources to bring them together in one place. Metadata are structured data that describe the characteristics, and semantics are aspects of the significance of open data sources. Integrating and converting data into a homogeneous format is a step of converting data into a format readable by everyone. Transformation into a digital format involves an activity whereby data that may not have been collected in one of the systems, that is, collected in paper form, is written to the selected system.

The next phase is data analysis, that is, the entrance to a phase where multiple activities can take place in parallel or only some of the activities can take place, as required by the open data creator. Some of these activities are integration and transformation, data analysis, data modeling, data creation and data visualization.

The last phase is publication and dissemination. The information is deposited in a specific repository and is reviewed and approved by the creators for the last time before publication. Subsequently, the data is selected in a chosen way, and shared and presented to potential users. At the end of the process, an open data publication report is created, and the data is updated over a period of time, at the decision of the open data creator.

## **5. WHY USE OPEN DATA?**

Encouraging the use of open data should be part of open data policies as it is an important factor in creating the intended effects. The use of open data can contribute to the potential increase of participation, interaction, self-empowerment and social inclusion of open data users (eg citizens) and service providers, stimulating economic growth and realizing many other benefits. According to the European Commission, open data bring both direct and indirect economic benefits from their use, while the Obama administration focuses on increasing transparency, participation and cooperation, which it believes will improve the quality of service to the American people (Zuiderwijk & Janssen, 2014). All the benefits and effects of open data can only be realized through the use of open data, which makes the system open. Open systems result in a new situation where the public can use and create open data through collaborations beyond borders and control and without burdensome restrictions.

The motivation and interest of identified users of open data rests on the benefits they bring. It was mentioned earlier that users of open data are the public, scientists and researchers, private organizations, but also public authorities. All of them are potential creators of open source. By leveraging data, the public becomes a participant in the data processing system and can process, enrich, combine data with other sources and even collect their own data (for example, via mobile phones). Traditional boundaries between public organizations and the public are changing or disappearing and almost anyone in the world has access to data, that is, the system is opening up. Scientists and researchers also have a great need to use open data to develop new knowledge and projects through research, which can ultimately improve and accelerate scientific progress. Open science is encouraged, through open data, methods and analyzes, thus ensuring better transparency and reproducibility of the result (Janssen, Charalabidis &

Zuiderwijk, 2012). Private organizations as users can use open data for market and competitive analysis, exploring and identifying potential customers, finding new innovative forms of business, adopting new skills, developing innovative solutions through open data support, and more. Cooperation in an open system, with minimal investment and harnessing the collective knowledge of society, could, through open projects, change the traditional channels of cooperation between government and citizens (Kassen, 2013).

## 6. CONCLUSION

The recommended process model for enabling the open data paradigm should be a guide for potential creators and simplify the creation of open data and make open data more available to the public. In addition to encouraging public authorities and private organizations, as creators or providers of data, to publish their data, it is important to create an open environment in which all users actively and interactively participate in a better open system. Current open data initiatives are largely procurement oriented (Kassen, 2013) and the effects and benefits of open data are hidden (Janssen, Charalabidis & Zuiderwijk, 2012). Understanding the outside world is neglected, so the feedback and insight into the user experience, that is supposed to help open systems improve continuously, is missing. Future research should focus on discovering the assumptions (practices, conditions...) for better cooperation of participants in the open system and on discovering new forms of cooperation through open data.

This paper also identifies why organizations should use open data in order to increase the effects that result from that use. As future work, the goal should be to identify and explore open data implementation projects from a user perspective. Upcoming researches should show who open data users are, for what purposes and how they are using it, and what value they are generating through open data application. Open data, in addition to the role of public information, should play a key role in value creation if used as input in open system processes.

**ACKNOWLEDGEMENT:** *This research is part of a project Twinning Open Data Operational that has received funding from the European Union's Horizon 2020 research and innovation programme under grant agreement No. 857592.*

## LITERATURE:

1. Bizagi. Bizagi Modeler version 3.1., <https://www.bizagi.com/en/products/bpm-suite/modeler>, last accessed 2020/01/20.
2. Conradie, P., Chonnei, S. (2014). *On the barriers for local government releasing open data*. Government Information Quarterly, vol. 31, Issue 1, pp. 510 – 517.
3. Gurstein, M. (2011). *Open data: Empowering the empowered or effective data use for everyone?*. First Monday, vol. 16, No. 2.
4. Janssen, M., Charalabidis, Y., and Zuiderwijk, A. (2012). *Benefits, Adoption Barriers and Myths of Open Data and Open Government*. Information Systems Management, Vol. 29, pp. 258 – 268.
5. Jupp1, S., et al. (2014). *The EBI RDF platform: linked open data for the life sciences*. Bioinformatics, vol 30, No. 9, pp. 1338 – 1339.
6. Kassen, M. (2013). *A promising phenomenon of open data: A case study of the Chicago open data project*. Government Information Quarterly, vol. 30, Issue 4, pp. 508 – 513.
7. Marr, B. (2017). *Data Strategy: How to Profit from a World of Big Data, Analytics and the Internet of Things*. Kogan Page
8. Molloy, J. C. (2011). *The Open Knowledge Foundation: Open Data Means Better Science*. PLoS Biology, vol. 9, Issue 12, pp. 1 – 4.

9. Mrgel, I., Kattel, R., Lember, V., McBride, K. (2018). *Citizen-Oriented Digital Transformation in the Public Sector*. Proceedings of the 19th Annual International Conference on Digital Government Research: Governance in the Data Age, pp. 1 – 3.
10. Poldrack, R. A., Gorgolewski, K. J. (2014). *Making big data open: data sharing in neuroimaging*. Nature Neuroscience, vol. 17, No. 11, pp. 1510 – 1517.
11. Reichman, O. J., Jones, M. B., Schildhauer, M. P. (2011). *Challenges and Opportunities of Open Data in Ecology*. Science, Vol. 331, Issue 6018, pp. 703 – 705.
12. Veljković, N., Bogdanović-Dinić, S., Stoimenov, L. (2014). *Benchmarking open government: An open data perspective*. Government Information Quarterly, vol. 31, Issue 2, pp. 278 – 290.
13. Zuiderwijk, A., Janssen, M. (2014). *Open data policies, their implementation and impact: A framework for comparison*. Government Information Quarterly, vol. 31, Issue 1, pp. 17–29.

# **SIGNIFICANT FACTORS IN THE PROCESS OF ADAPTATION OF A FIRST GRADER TO THE SCHOOL ENVIRONMENT**

**Venelin Terziev**

*National Military University, Veliko Tarnovo, Bulgaria*

*University of Rousse, Rousse, Bulgaria*

*terziev@skmat.com*

## **ABSTRACT**

*The new social role of a child at school is preceded by a series of attractive external stimuli (clothing, knapsack, textbooks, exercise books, school building), which through their family and kindergarten orient them in the forthcoming comprehensive change of their lives. These external stimuli are not enough for a child to adapt quickly to the rights and obligations at school, as well as to the changed evaluation criteria of their activity, mainly learning.*

**Keywords:** *Children, School environment, Factors, Education, Adaptation*

## **1. INTRODUCTION**

Preparation of children for school within the contemporary challenging conditions of public development is mainly related to their psychological, physical, moral and social readiness for school. Whereas the psychological readiness is defined through the development of intellectual processes along with the increase of knowledge about reality and cognitive skills of children; whereas the moral readiness is measured by the adult-child, child-child relationships and mainly relies on the development of disciplined behavior of the future students, and physical readiness is characterized by the health and vitality of children, then social readiness generally relates to the new situation of the child in school environment, to acceptance of a new social role of a student, which in reality changes the nature of their relationship with parents, teachers and adults (Petrova, 1989).

Social readiness for school is related to the development of a number of the child's personal capabilities and qualities, the most important of which are: independence in behaviour according to the type of their relationships with adults and peers, flexibility in the organization of their own lives combined with the ability to overcome difficulties, stability in behaviour, well-being and desire to work. Generally speaking, social readiness is a complex of social capabilities and social behaviour that develop under the influence of purposeful education.

## **2. SIGNIFICANT FACTORS IN THE PROCESS OF ADAPTATION OF A FIRST GRADER TO THE SCHOOL ENVIRONMENT**

Social behaviour of an individual still has not received its well-deserved place in contemporary literature. On the other hand, it has not become the goal of modern education, even though the social behaviour of a person combines significant qualities such as sympathy, independence, collaboration, friendship, mutual assistance and responsibility that shape their social maturity. Social behaviour represents a complex of various actions that reveal the relationships between people in a certain community and arise under the influence of different motives and external stimuli. Social behaviour is defined by social peculiarities. They, in turn, manifest themselves in the child's ability to deal with other children, to be patient with them, to respond to other people's experiences, to be ready to help if necessary, etc (Georgiev, 1971). The formation of social abilities develops in the process of interaction of an individual with the public environment, i.e. in specialized conditions of public education, at kindergarten, at school, assisted by the family (Figure 1-2).

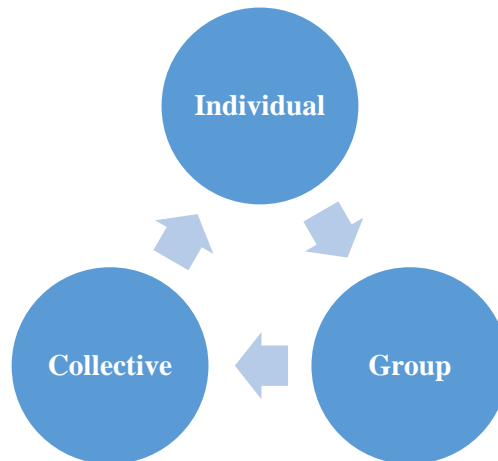

Figure 1: Types of school-family relations

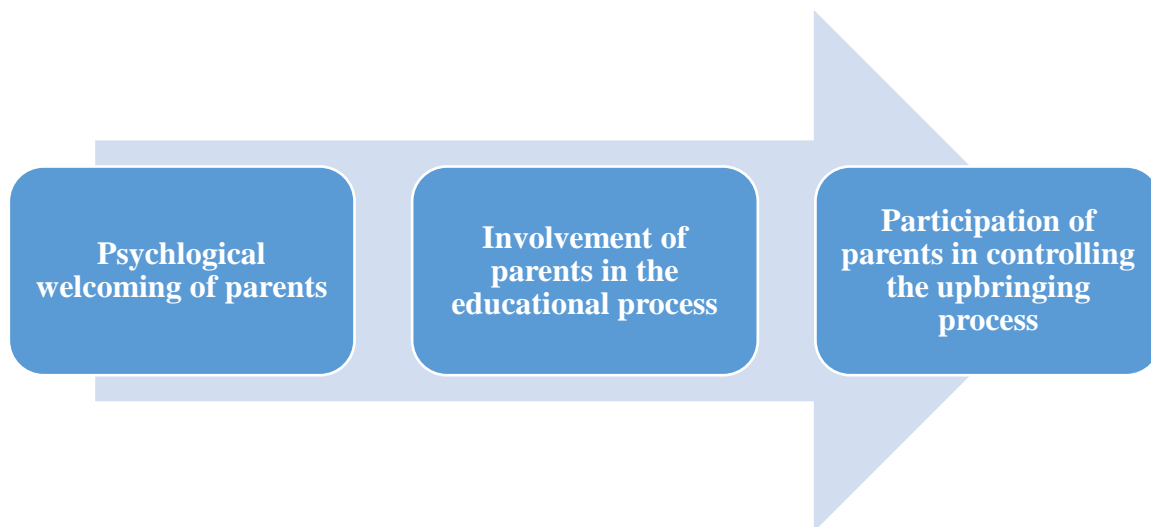

Figure 2: Main guideline of teacher-parents collaboration

### 2.1. Psychological characteristics of the student's personality in first grade

Development of child's personality is influenced by the social conditions and the decisive role of upbringing. To a question: When a child becomes a personality? - we should answer: When a few grains of sand become a heap! Social conditions in the family contribute to the gradual development of child's mental soundness, to certain resistance in behaviour towards adults and other children. This is not just a result of the new social conditions of life, but also of the growing opportunity for a personality to make an impact within these conditions. The causes that determine the gradual transformation of a human individual into a personality at the end of early childhood are, at the same time, the causes and the driving forces behind the development of a first grader personality. The dialectical interaction between development and the conditions in which the child lives gives the most accurate picture of the dynamics of their development. A first-grader engages in a new type of relationship with others. From a stage of co-working with adults through early childhood and pre-school years, they move on to relatively independent behaviour (Pavlov, 1951). The level of intellectual development of a child enables a first-grader to accept different patterns of behaviour by describing actions or by examples in works of art. The new type of communication that students establish with each other plays a vital role in their development. The young student does not only have the need to communicate with their peers. When playing or performing tasks with each other, they establish relationships similar to those observed in adults. This way, they develop habits that help them feel part of a



society, shape their relations with others based on equal participation in activity. The impact of class on the development of child's personality is growing significantly. A first-grader basically learns about the norms of relations with other people, applies them in their relations with other students, adapts the learned rules to various specific situations. In the process of communication, the child realizes their place in the class, which is manifested in the classmates' attitudes towards them. Such place is extremely important for the right development of child's personality. Therefore, teachers should purposefully assist in developing the best status for each child, with a view to their proper upbringing and development. Development of the basic activities such as learning, playing and working is the main factor contributing to child's personality. Making of these activities more diverse and comprehensive determines the development and differentiation of the intellectual, moral, aesthetic and decision making qualities of an individual (Pavlov, 1951). Such capacities and qualities of a first-grader become more resistant systematized and are fundamental for a higher degree of social maturity. The most favourable conditions for the social interaction of a child with peers are: by learning, working and playing. These activities are the best at manifesting and developing those traits and qualities of child's personality and also developing its core and its motivational system. One of the most important conditions for this is the collective organization of the activities, because it creates the greatest opportunities for interaction and communication between the first-graders. Learning activity is of utmost importance for the development of students. Involving children in properly organized learning activity rises awareness of their behaviour and helps understand the emerging traits and qualities of child's personality. Through work a young student is actually involved in the activity of adults. Thus, even though it originates from playing, it is a step forward in satisfying the social need for students to participate in the lives of others. The developmental function of the work depends on its gradual complication. Its improvement should be mainly focused on the development of its collective character. The role and importance of playing activity in the lives of first-graders changes. It becomes dominated by the learning activity when they go to school. However, it continues to play an important role in the lives of elementary school students. The motives of a first-grader behaviour change their content and structure.

With proper organization of the educational process, the changes that occur in the motivation system are very significant. The most crucial role in motivating students' behaviour is the desire to imitate adults. These motives have great motivational power because they are a psychological expression of the child's need to ensure the best possible relationship with people (Desev, 1998). Motives related to the interest in playtime itself are important to the behaviour of first-graders. They are defined by students' behaviour that comes from their certain role in a game. The strength of the motives is explained by attractiveness of the game and by the fact that children feel themselves confident as equal participants of social life. At that age, development of cognition, curiosity and competitiveness begins. Moral motives are of particular importance in the development of a first-grader personality. Younger children are more willing to perform moral actions towards those adults (Nikolov, 1980) and peers to whom they feel sympathy. A child starts school with developed sensory organs. Based on that, the development of child's feelings that began in the previous ages continues. Visual sensations play a huge role in the pedagogical process, because through them students receive nearly 80% of the information about reality. In addition to distinguishing the primary colours, children have the ability to capture colour shades. The development of visual acuity is particularly impressive. Auditory sensations develop dynamically together with the process of learning to read and write. Thus, it is difficult for us to differentiate purely auditory sensations. Rather, we can talk about auditory-visual, auditory-motor and other sensations. Motor sensations develop in several ways. Above all, accuracy and correctness are enhanced.

The development of motor habits is accomplished in rather a short time. It is easier for young children to perform general movements associated with walking and running, and fine movements like drawing, sewing, etc. are more challenging for them, resulting in more inaccuracy. They develop qualities such as dexterity, agility, flexibility, mobility, grace and so on. The motor sensations also develop through games: playing with toy cars, sledding, skating, hiding and so on (Amonashvili, 1996).

As a result of including a first-grader in new activities at school and new requirements, their memory gradually develops and improves, they develop involuntary memory, meaning that they easily learn many things without specifically paying attention to them. Their memory becomes activated and from the rich variety of surrounding things, students remember the thing that gives them the strongest impression, thus is most striking and interesting. They memorize directly through action, effortlessly, without the set task or purpose (Filipchuk, 1980a). In first grade a child is asked to remember facts, numbers or rules. The child needs to activate their voluntary effort in order to remember the necessary information successfully and consciously. Therefore, children together with the involuntary memory start to develop the voluntary one. They can memorize voluntarily the defined requirements and orders given to them by adults, mainly teachers. The memory of a first-grader is enhanced mainly by the requirements related to learning. The students find themselves in a classroom setting, where the teacher daily teaches them, sets certain performance requirements, which become an objective prerequisite for memory development. In order to successfully cope with their school requirements, the students must learn to manage their memory: remember how to sit at the desk, how to write letters, etc. All this is related to the rapid increase in memory capacity. Visual memory remains useful at this age.

Children memorize certain information better and for longer periods of time. However, educational content consists not only of images, colours, forms, but also of a system of concepts, judgments, conclusions, data and so on. This inevitably leads to the rapid development of verbal and logical memory. During this period, children develop really fast. They become more active and emotional. Their imagination produces far fewer images comparing to adults, since they have little life experience. Imagination is directly dependent on communication with adults and the involvement of the child in various activities. In the process of communication, through speech, it becomes necessary to create images that are not related to directly perceived objects and phenomena. For instance, by listening to a fairytale or story, on the basis of their experience and knowledge, the child develops an opportunity to create new sets and combinations of images and that is when their imagination manifests itself (Yonchev, 1972). Development of imagination during communication with adults is related to activation of the sign function of our consciousness, clearly observed during playing and learning. The sign function is performed by replacing one object with another or with their images using verbal signs (words). This period of child's development is particularly characterized by imaginary pictures that are the key to children's imagination. They are distinguished by their specificity, clarity, efficiency, changeability and rapid transitivity. The peculiarity of children's imaginary pictures is that they always appear with feelings. These feelings usually create very strong emotions. Thinking depends on the knowledge the child is gaining, and learning itself takes place during thinking while solving numerical problems. Knowledge is not transferred mechanically or neither it is automatically accumulated in the mind of a child during communication with adults. We master it while thinking, which is aimed at developing the connections and relations that exist between objects and phenomena in reality.

Through practical actions we enrich our sensory experience, broaden our horizons and create opportunities to understand not only external but also some internal connections and relations between objects, to reveal some elementary causal dependencies and consequences.

A first-grader gets to know these connections and relations in three forms (Lyublinskaya, 1972a):

- In the form of direct interaction with objects. This is where a so-called visual-thinking process is activated;
- In the form of images – visual;
- In the form of logical reasoning - logical thinking.

The most important function of the visual thinking is to obtain basic information about hidden properties of the object. Whereas through perceptions the child learns about the external properties of objects, such as shape, size, color, through visual thinking they recognize some hidden properties of objects and phenomena. We can characterize visual thinking by the fact that solving a series of problems is accomplished by the use of images without applying practical actions. Its important feature is the re-creation of the subject from its various perspectives, which appear not in logical but in factual sequences. The emergence of visual thinking is an important step in the development of thinking in general. The development of logical thinking implies the development of logical operations (analysis, synthesis, comparison, summary) and logical forms (concept, judgment, reasoning, questions), through which we learn of the most essential, hidden causal relations and dependencies. The logical thinking is basis for successful thinking, which is a prerequisite for the successful involvement of a child in education, and participation of a first-grader in the learning process, in turn, contributes to its further development. Involuntary attention is dominant in life of first-graders. It depends on the development of basic processes of the central nervous system, such as excitation and inhibition. Both these processes and the attention are not yet well developed. Attention is now focused on external stimuli that activate our senses. That is why child's attention is known as sensory. The child can be focused until a new interesting object appears that grabs their attention. For this reason, children find it difficult to focus on one task for a long time, especially if it is not exciting (Boneva, 1969). Although involuntarily, attention is constantly evolving. It is changing throughout the school year. The development of attention is particularly observed in terms of its properties such as sustainability, volume, distribution and mobility. The sustained attention of a first-grader is the ability of consciousness to focus involuntarily on various stimuli for a long period of time. For instance, in the beginning students are quickly distracted by fatigue, bad habits or improper upbringing. Attention volume is still limited, although its capacity is expanding significantly compared to the younger children. This is the ability of a child to concentrate not only on one object, but also on two, three or more objects. There has been some progress in the ability to distribute attention between different strands of a certain activity. Children master attention mobility in the process of various activities. For instance, when they attend physical education class, they successfully transfer their attention from walking to exercising, running, etc. The aforementioned qualities of attention manifest themselves as a whole in the activity of a young student. While evolving one quality contributes to the development of others. The greater the volume of attention, the more distributed it is, and the more developed the quality of distribution, the greater the possibilities of its mobility. Child's speech as a mean of verbal communication arises and develops during their continuous contact with adults who surround them. It is impossible without the social environment the child lives in. The most crucial point in the active development of a child and their speech is that they start learning the language, the grammar and reading in their native language at school. This knowledge helps them master the language better, speak well and write competently.

As a result, the child's speech is actively developing in the following directions: enriching the vocabulary and understanding the meaning of the words. Students start mastering the grammar rules, understanding the vocabulary, developing phonemic hearing, the functions of speech and the sense of language (Boneva, 1970). The child's speech is developing well, especially their vocabulary. There is a significant increase in their vocabulary during the first year at school. By the age of seven, the child has mastered about five thousand words. They are commonly used, related to activities and household, social life, moral standards, education, culture and so on. Of course, not all children make full use of this variety of vocabulary. The degree of speech development of each child is different. Some children use their active vocabulary to full extent, while others have limited capacity of their active vocabulary, although they still are able to memorize a considerable number of words. The assumption that elementary schooling is the time of most rapid development of human speech is associated not only with enrichment of the vocabulary. This process is mainly the result of gradual and regular development of literacy: reading and writing. When children develop their literacy, their cognitive abilities also improve, their outlook expands, they broaden their horizons about the rich world of literature, science and technology. However, mastering of reading and writing does not only contribute to quantitative increase in vocabulary, but also to a deep meaningful understanding of the meaning of each word. With more communications, the sense of language begins to develop as well. Without understanding the phonetics, vocabulary or grammar of their mother tongue, children not only begin to express themselves correctly, but they often notice mistakes in the speech of others. At no other age can we observe such intense and dynamic development of speech. The acquired knowledge during this period is the foundation for further development of a child.

## **2.2. Kindergarten as an important factor of first-graders adaptation**

One of the most important tasks of pre-school education is the comprehensive preparation of children for school, because it determines the effectiveness of school education (Forst, 1976). To successfully cope with the requirements of the elementary school, the child attending kindergarten must acquire certain knowledge and skills in such volume and quality that will serve them as a valuable prerequisite for the acquisition of the first grade material. Apart from this, they should also develop those technical personality qualities that will enable a higher level of intellectual activity. When children go to first grade they are supposed to be ready to learn, the practical realization of which requires a theoretical justification of both the problem of school preparation and the closely related problem of continuity between kindergarten and the next educational degree. In fact, preparation for school implies reaching a certain level, that ensures the transition to the new mental and personal traits, necessary for the development of new needs, motives and abilities. Preparing children for primary education has always been a major problem for teachers and psychologists in our country. A positive side of this preparation is that it never implies developing literacy and performing special program tasks, as well as introducing contents of certain school subjects (Valkovoy, 1959). Many authors in their works are looking for specific qualities of first-graders in terms of performing common tasks, as well as means of accomplishing them. For instance, in his work P. Nikolov outlines in a spiral model the tasks that the kindergarten solves, which make it possible to complicate these common tasks in elementary school. The organized learning process in kindergarten, on the one hand, contributes to children development, and on the other hand, it also solves the special task that is to develop elements for learning activity and to assist the transition to school. To learn the lessons content children need to have acquired general learning skills as they go to school. A situation of an organized structure for performing the training creates conditions for the development of elements of learning activity, which will gradually become leading at school. The development of learning activities in the situation is related to the learning process and provides its developing functions.

Children develop learnability, which is expressed in their ability to deliberately obtain a system of knowledge, skills and habits. Children learn a system of cognitive actions, without which it would be challenging for them to master the system of mathematical knowledge and skills for connected speech. In order to acquire certain knowledge, skills and habits, children have to become accustomed to being guided by their tasks. Solving a task is purposeful and deliberate when it comes to a particular didactic result. Expectation of the result stimulates cognitive activity, subordinates the available experience to the tasks (Forst, 1976). Solving new tasks in a new cognitive situation enhances cognitive activity, stimulates thinking activity and most of all prepares children for the transition from kindergarten to first grade. One of the most complicated elements of the learning process is planning the activity. It creates conditions for greater independence, diversity and creativity. For example, a child is encouraged to think in advance about the content of their story or drawing and to put a story title or topic on the picture they are drawing. The development of learning activity involves an assessment of the result. With the help of a teacher, a child participates in the evaluation process.

Under the direct guidance of the teacher, the elements of learning activity and the acquisition of certain skills described above have been developing in unity. Regardless of the degree of child's awareness, the knowledge must be organized, purposeful and conscious. It prepares a student for learning at school. The components listed above correspond essentially to the structure of the learning activity presented in the pedagogical literature. P.S. Yakimanska, for instance, points out the following components: needs and motives, learning tasks, their solution, various techniques for their implementation, control and evaluation of learning outcomes, analysis of ways to achieve them. The development of elements of learning activity leads to early development of systematic ideas and concepts for mastering learning skills that determine the child's mental readiness to learn. The presence of these components creates an opportunity for the child to understand common ways of learning, which leads to mental development, facilitates the solution of learning tasks and provides independence. In addition to these evolving educational tasks, the situation prepares children for the transition to the lesson and provides overall preparation for school. Children of pre-school age do not perform academic activity. Nevertheless, situations as a form of learning process constitute a didactic system whose components interact and ensure the unity of learning, upbringing and development.

By synthetically combining situations and skills learned, we gradually create conditions to control the interconnection between objects and phenomena, and the basic systematization prepares the transition to the school system. The unity of integration and differentiation create skills for a global approach to learning about the environment, facilitating a common approach to enriching the experience. We should not underestimate the educational opportunities of the situations that children receive through educational process. Usually, the topic and content of the situation are aimed at getting to know the components of different work processes. It is especially crucial here to emphasize labor as a human need; motives for carrying out the work processes, social significance of the outcome, relationships in work interactions; qualities that people must possess in order to achieve work results and to create material and spiritual values. In addition to these educational functions directly related to the content of the situation, the tasks that relate to the personal development of the child and determine their progress in the learning process are particularly important. It means we should help develop a desire of a child to learn, solve tasks and follow orders. Together with the attitude towards the student, the situation contributes to the development of moral readiness for learning at school. By solving specific tasks, the child learns to overcome difficulties, to be patient, persistent and to control their behavior.

As a result of personal development, primarily related to the emergence of child's desire to learn, to show positive attitude towards learning, an interest in gaining knowledge and to create moral and role-playing activities for school, children gradually develop certain level of their moral upbringing. It also provides social and moral preparation for school, which implies love for work, a sense of responsibility and independence. School-based social preparation involves the use of general teaching functions of the education in order to gradually prepare for school. This readiness is necessary for creation of motives for learning and a responsible attitude towards duties. Such pre-school preparation partially characterizes the child's social development (Petrova, Sheytanova, Slavova, 1978). The social development traits that prepare the child for a change of community and their place at school develop during different types of activities - learning, playing and working, ensuring not only the availability of knowledge and development of general mental abilities, but also a positive attitude towards learning and the school. The problem of personal readiness is one of the decisive factors for a successful change of the position of the child who becomes first-grader. If a child goes to first grade eager to learn and positive attitude towards teachers and school, they will demonstrate their cognitive activity and curiosity, as well as easier adaptation to the new community, united by new goals and objectives. The student, both in and out of the classroom, will take the so-called position of “participant in the learning process and in the whole life of the school” (Sohina, Tarontaevo, 1977).

### **3. CONCLUSION**

Students upgrade their skills and habits when they personally refer to the knowledge they need to acquire and when they self-improve socially and morally. Each child expects to go to school, attracted by the new role of a student. The right personal position depends on their perception of the school and their functions as a student. Therefore, a well-organized preparation is needed at the kindergarten with regular visits to a nearby school (Terziev, Bankova, Dacheva, 2019-a; Terziev, Stoilova, 2019b-c). The child must be convinced that the way to social participation, like the people they meet, is through school. And the education that will make them like these people is related to life in the student community. This is the second decisive problem along with the organization and management of the cognitive process, to create not only cognitive but also personal motives for behaviour when children enter school. This process is also integral. It takes place in the overall activity of the child and, above all, in the collective forms of learning, playing and working. A personal attitude towards school combines qualities such as curiosity, love for work, independence, responsibility and duty. Therefore, the positive attitude towards the school as a unity of the program content and an effective educational process is permanent. It is not limited to observation and conversation or just a separate work of art. Attitude towards the school becomes an important task in the implementation of the program content in other topics, which is to get acquainted with the public environment, with different work processes, with the arts and so on. Developing learning skills in unity with the ability to participate in collaborative activities is also a prerequisite for increasing interest in school life and a willingness for intellectual effort in learning the material. Personality readiness is adequately achieved when teachers create conditions at school that would interest students in learning, help them experience pleasure overcoming difficulties. Generally speaking, social adaptation is a state of mental and spiritual equilibrium of the individual towards the social community. The social adaptation takes place where it is necessary to overcome the mental tension in the transition from one situation to another (Dikov, 1987). Through different activities in the preschool age, children develop necessary skills and habits related to their social, moral and mental preparation for school. This preparation begins from the early age in the family.

The interaction and interconnection between the three types of activities (playing, learning and working) create the necessary conditions not only for mental development, but also for the social realization of the person. Continuity from kindergarten to school means to educate through games these communication-organizational skills, which later would become of utmost importance for study and work. In the process of game, children reflect some aspects of the adults' life they have previously learned. More important here is not the quantitative information reflected in the game, but the modeling of social situations. The whole educational process in the kindergarten reflects social reality. It manifests itself in the nature of knowledge that children receive about the surrounding world and in the knowledge, skills and habits they develop for living together in the children's community. Children learn norms of behavior, gradually obeying the rules that determine their place. This process is constant and fully implemented in various activities. Through unity of these activities are made the preconditions and is reached the formation of socially important traits that provide opportunities for complete adaptation of the child at school.

#### LITERATURE:

1. Petrova, E. (1989). *Podgotovka na detsata za uchilishte*, S, 1989 (Петрова, Е, *Подготовка на децата за училище*, С, 1989).
2. Georgiev, L. (1971). *Psihologicheski problemi na obuchenieto v nachalno uchilishte*, S, 1971 (Георгиев, Л., *Психологически проблеми на обучението в начално училище*, С, 1971).
3. Pavlov, P.I. (1951). *Sabrani sachineniya*, t.3, M, 1951 (Павлов, П.И. *Събрани съчинения*, т.3, М, 1951).
4. Zaporozhets, A.V., Elkonin, D.B. (1966). *Psihologiya na detsata ot preduchilishtna vazrast*, S, 1966 (Запорожец, А.В., Елконин, Д.Б., *Психология на децата от предучилищна възраст*, С, 1966).
5. Desev, L.N. (1998). *Psihologicheski problemi na vazpitaniето*, S, 1998 (Десев, Л.Н., *Психологически проблеми на възпитанието*, С, 1998).
6. Nikolov, P. (1980). *Problemi na npravstvenata motivatsiya*, S, 1980 (Николов, П., *Проблеми на нравствената мотивация*, С, 1980).
7. Amonashvili, Sh., A. (1996). *Zdraveyte, detsa! Kak ste, detsa!*, S 1996 (Амонашвили, Ш., А., *Здравейте, деца! Как сте, деца!*, С 1996).
8. Filipchuk, G.D. (1980a). *Znaete li v svoevo rebyonka*, M, 1980 (Филипчук, Г.Д., *Знаете ли в своево ребьонка*, М, 1980).
9. Yonchev, V.A. (1972). *Semeystvoto i vazpitaniето na deteto*, S, 1972 (Йончев, В.А., *Семейството и възпитанието на детето*, С, 1972).
10. Lyublinskaya, A.A. (1972a). *Za psihicheskoto razvitie na detsata*, S, 1972 (Люблинская, А.А., *За психическото развитие на децата*, С, 1972).
11. Boneva, A.D. (1969). *Vashiyat parvoklasnik*, S, 1969 (Бонева, А.Д., *Вашият първокласник*, С, 1969).
12. Boneva, A.D. i kolektiv. (1970). *Roditelite i vazpitaniето na deteto v uchilishte*, S, 1970 (Бонева, А.Д. и колектив, *Родителите и възпитанието на детето в училище*, С, 1970).
13. Forst, V. (1976). *Deteto predi da tragne na uchilishte*, S, 1976 (Форст, В., *Детето преди да тръгне на училище*, С, 1976).
14. Valkovoy, E.I. (1959). *Shkola detskii sad i semya*, M, 1959 (Вълковой, Е.И., *Школа детски сад и семья*, М, 1959).
15. Petrova, E., Sheytanova, Ts, Slavova, R. (1978). *Podgotovka na detsata za uchilishte*, S, 1978 (Петрова, Е., Шейтанова, Ц, Славова, Р., *Подготовка на децата за училище*, С, 1978).

16. Sohina, F.A., Tarontaevoy, T.V. (1977). *Podgatovka detey shkole v detskam sadu*, M, 1977 (Сохина, Ф.А., Таронтаевой, Т.В., *Подготовка детей школе в детском саду*, М, 1977).
17. Terziev, V., Bankova, D., Dacheva, I. (2019). *Approaches in governing the educational processes in schools*. // XXII International Scientific Conference: The power of knowledge (11-13.10.2019), Kavala, Greece, Institute of Knowledge Management, Skopje, 34, 2019, 2, pp. 311-316, ISSN 1857-923X (for e-version), ISSN 2545 – 4439 (for printed version).
18. Terziev, V., Bankova, D., Dacheva, I. (2019a). *Theoretical underpinning of the problems related to pedagogical excellence and pedagogical creativity in the initial stage of school education*. // XXII International Scientific Conference: The power of knowledge (11-13.10.2019), Kavala, Greece, Institute of Knowledge Management, Skopje, 34, 2019, 2, pp. 411-417, ISSN 1857-923X (for e-version), ISSN 2545 – 4439 (for printed version).
19. Terziev, V., Stoilova, M. (2019b). *Analysis of the system of school education. Strategy settlement process*. // 21 st International scientific conference: The teacher of the future, Budva, Montenegro, (07-09.06.2019), Institute of knowledge management – Skopje, Macedonia, 31, 2019, 6, pp. 1851-1857, ISSN 1857-923X (for e-version), ISSN 2545 – 4439 (for printed version).
20. Terziev, V., Stoilova, M. (2019c). *Experience of SWOT analysis in the system of the Bulgarian education*. // 21 st International scientific conference: The teacher of the future, Budva, Montenegro, (07-09.06.2019), Institute of knowledge management – Skopje, Macedonia, 31, 2019, 6, pp. 1887-1893, ISSN 1857-923X (for e-version), ISSN 2545 – 4439 (for printed version).
21. Dikov, T. (1987). *Savmestnata rabota na uchilishteto i semeystvoto*, S, 1987 (Диков, Т., *Съвместната работа на училището и семейството*, С, 1987).



## **FAMILY'S ROLE IN THE ADAPTATION OF CHILDREN IN SCHOOL**

**Venelin Terziev**

*National Military University, Veliko Tarnovo, Bulgaria*

*University of Rousse, Rousse, Bulgaria*

*terziev@skmat.com*

### **ABSTRACT**

*The problem of human adaptation to the rapidly changing conditions of modern life is particularly important for modern children who from early age are raised under conditions of frequent adaptation and re-adaptation to new environment. Each period of transition to a new environment is associated with stress and number of difficulties for the child.*

**Keywords:** *Children, School, Family, Education, Adaptation*

### **1. INTRODUCTION**

The child's development is a complex and diverse process, which occurs in continuous interaction between the child's personality and the environment. The mental development occurs in a process of active assimilation, optimal adaptation of the child to the environment requirements in which they live. This determines the importance and significance of the problem for the child's adaptation to different conditions and environments. Modern living conditions characterized by the rapid pace and scale of environmental transformations with constantly increasing demands on productive scientific and technological progress and with an increasing amount of information and a variety of psycho-emotional workload place the problem of adaptation of man to the changing environment among the most important general theoretical problems in modern science. The urgency of this issue is clearly expressed by its consideration in many scientific and practical fields from various aspects: biological, medical, social, psychological, pedagogical and others.

### **2. FAMILY'S ROLE IN THE ADAPTATION OF CHILDREN IN SCHOOL**

The contemporary literature and pedagogical practice very often discusses children's maladjustment, the deviations and difficulties in their upbringing. Facilitating adaptation and shortening adaptation time is a particularly urgent problem and a successful solution to it can and should lead to a reduction of the number of children who failed to adapt, who are difficult to be educated and of the deviations in their behavior and health. It is well known that the more psychologically and pedagogically focused the adaptation is, the faster and easier the child relates and assimilates new circumstances and requirements, the greater their opportunities for development and formation of right attitude are. Continuity between family and kindergartens and between them and primary schools should be addressed as a particular issue in the problem of children's adaptation to different living conditions, i.e. moving from one environment to another. The full implementation of such continuity gives opportunities for optimal adaptation of the child to the environment, prevents "stresses", "crises", traumas, retention in their development and enables continuous process of development of knowledge, skills, abilities and skills of an individual (Terziev, Bankova, Dacheva, 2019-a). In this regard, among the other goals for the upbringing of children, a new one should be set, namely to provide conditions for the adaptation of modern children to the conditions of the new environment in an easier and faster way. The term "adaptation" (from Latin *adaptio* - to adapt) has wide application in the natural, social and technical sciences. Sociology, psychology and pedagogy make extensive use of "adaptation" to indicate a state of equilibrium in the relationship between the individual and the social environment. The term "adaptation" in the broad sense of the word is based on a historical (evolutionary) principle and denotes the whole system of reactions of living systems

(individual, species) that have an active, guiding character. In a narrow sense, the term “adaptation” reflects only the ontogenetic aspect, i.e. process of interaction, equilibration of the living organism with the environment in its individual life. The universal nature of adaptation is strongly emphasized by I.P. Pavlov. His concept of adaptation is about the unity of environment and organism, “the most common characteristic of a living being is that it responds with the help of its defined specific activity not only to the external stimuli to which they have been exposed since birth, but also to other irritants that appear over the course of existence; in other words, a living organism has the ability to adapt” (Sechenov, 1952). To conclude, adaptation, as a necessary condition for the existence of the organism, includes the interaction of the organism with the environment. In this case, adaptation is an expression of the unity of internal (organism) and external (environment) conditions. Adaptation is the ability of the organism to adjust its activity to the needs of the internal and external environment. Human development naturally requires maintaining a continuous interaction with environment and constant adaptation to it. A person is adapted to an environment when it can meet its requirements or when it responds adequately to the effects of the environment (Pavlov, 1951). Human-environment interaction is accomplished not only by the physiological activity of man as a biological being, but through the path of material and spiritual production, through the forms of their social activity. A.D. Andreeva describes human adaptation in three directions (Andreeva, 1973):

- The set of adaptive responses of human society as a whole to its natural environment.
- The adaptive reactions of an individual to changes in the surrounding social and natural environment.
- Entry of individuals into different social roles, i.e. in the sense of social adaptation.

From a philosophical point of view G.T. Dichev (Dichev, 1973a) defines the adaptation of man as “a complex process of the emergence, development and preservation of the state of physical, spiritual and social well-being by changing the organism according to the requirements of the present state of nature and society or the changing social conditions of people's lives to the needs and living conditions of each individual, or both at the same time”.

A person's ability to communicate, socialize and to be able to absorb social experiences in the form of knowledge through language as a means of communication provide thoughtful anticipation and preparation for environmental change, which are specific to humans only. Through their activity they not only realize but also regulate and control their relations with the environment, influencing it accordingly to their needs. On the basis of this, G. Dichev points out that the ability to participate in socially useful work, creative activity and to engage in certain adequate interactions with other members of the society in which people live is the main factor for the adaptation of the person and the preservation of their social functions. Creating the ability to adapt to the complex of social relations in different social microgroups is an increasingly crucial component in the development of an individual. Therefore, in the modern conditions the society and nature have the greatest opportunity for optimal adaptation to the needs and capabilities of every person (Dichev, 1973a). Our neuroplasticity provides us with too many opportunities and flexibility in adapting to various conditions and environmental influences. When it comes to adaptation, contemporary literature discusses the adaptive capabilities of the higher nervous activity in relation to biological or mental “stressors” (substance, agent, irritant, stress-induced effect). The way and the basis on which adaptation takes place is an issue that has received much attention. Solving it has become the focus of numerous theories and concepts. The physiological side of human adaptation to conditions of a certain environment is synthesized in I.P. Pavlov's theory of the dynamic stereotype. Normally, there are numerous irritants on the cerebral cortex, both from the outside world and

from the internal environment of the body itself. “Some of them”, according to Pavlov, “are being investigated (orienting reflex), while others have a variety of conditional and unconditional effects” (Sechenov, 1952). They all meet, collide, interact and have to be systematized and balanced in a dynamic stereotype. The dynamic stereotype supports the person in their activity, saves the consumption of energy of the nervous system when they respond to the surrounding external conditions. Throughout our lives under both bioclimate and social conditions people create a relatively stable dynamic stereotype that reflects their certain adaptability. Some authors view adaptation as a compensation process when environmental connectivity is lacking or insufficient, i.e. when the environment changes - H. Selye. The process of human adaptation involves psychological mechanisms that are not yet well studied. In biomedical and philosophical literature various theories have emerged that explain the course (stages) of adaptation. The concept of the Canadian scientist H. Selye is widely known and spread. According to him, different irritants (stressors) cause stress. He defines the set of general protective reactions that help restore the equilibrium as adaptive. He also defines three stages in the activity of the adaptation mechanisms. It is noteworthy that in both theories the adaptation period is rather difficult and stressful, which keeps our nervous system in tension. Such a condition has a negative influence on the functions of the whole organism (Pavlov, 1951). All this indicates that the human adaptation to nature and the social environment cannot be accomplished only on the basis of ready (innate) mechanisms. Based on this, it can be stated that the process of adaptation can be governed and coded throughout the process of learning. Consequently, a little child can be assisted during difficult and sometimes painful process of adaptation. Applying appropriate methods and forms of education ensure the readiness of children and create favorable conditions for facilitating adaptation as they move from one environment to another. Thus, education and upbringing purposefully guide the quick and easy connection of the child to the new environment, which increases their opportunities for fuller adaptation, for more effective and correct development and upbringing. This is precisely what sets the scientific and practical solution to the problem of continuity in the upbringing between the family, the kindergartens and the school. The realization and effectiveness of continuity requires that it is based on the knowledge of the mechanisms that make a fuller, more complete adaptation to an environment.

### **3. PARENTS’ RESPONSIBILITY FOR UPBRINGING**

Parent and community involvement in upbringing are closely connected and complement each other (Figure 1). We cannot deprive ourselves of parental upbringing if we want our children to grow up strong personalities, with abilities and knowledge. Do parents always see their children the way they really are? Do we pay enough attention to them? Do they provide enough help for children to enter all the 'miracles' of their world? Most parents have the best wishes and intentions to raise their child. They should become good and hardworking people, graduate from school, take up a profession, have a fulfilling life and find their place in life and society. They have to be honest and diligent, respect their parents and treat the loved ones with care. However, every child develops in a different way. We cannot always be satisfied with the upbringing results. We do not always fully realize the extent to which the behaviour and character of the child are determined by parental upbringing. In the beginning we do not see what is wrong with their development, so we tend to think that there are no problems. However, the primary school teacher clearly recognizes the impact of family upbringing and its role in the quick adaptation of children to the school environment. There are children in the classroom who feel comfortable among their classmates. They work calmly, they are responsive, know how to engage others in their games. But there are also children who are complicated and behave boldly, whimsically, willfully, and rudely. Differences in family upbringing are also noticeable in the child's attitude toward classmates, teachers and teaching process. For the

proper start of the child in school and for their success, the particular upbringing in the family is of utmost importance (Zdravkova, 1978). And this means that the child should understand the organization of life and relationships in the family from the example of parents' behavior and from their upbringing ability in a broad sense. This includes the knowledge that parents have about the upbringing and development of the child, careful monitoring of the child and the conscious attitude to their problems. Last but not least, the rapid adaptation of children is also influenced by the growth of the child, what knowledge and abilities they gain.

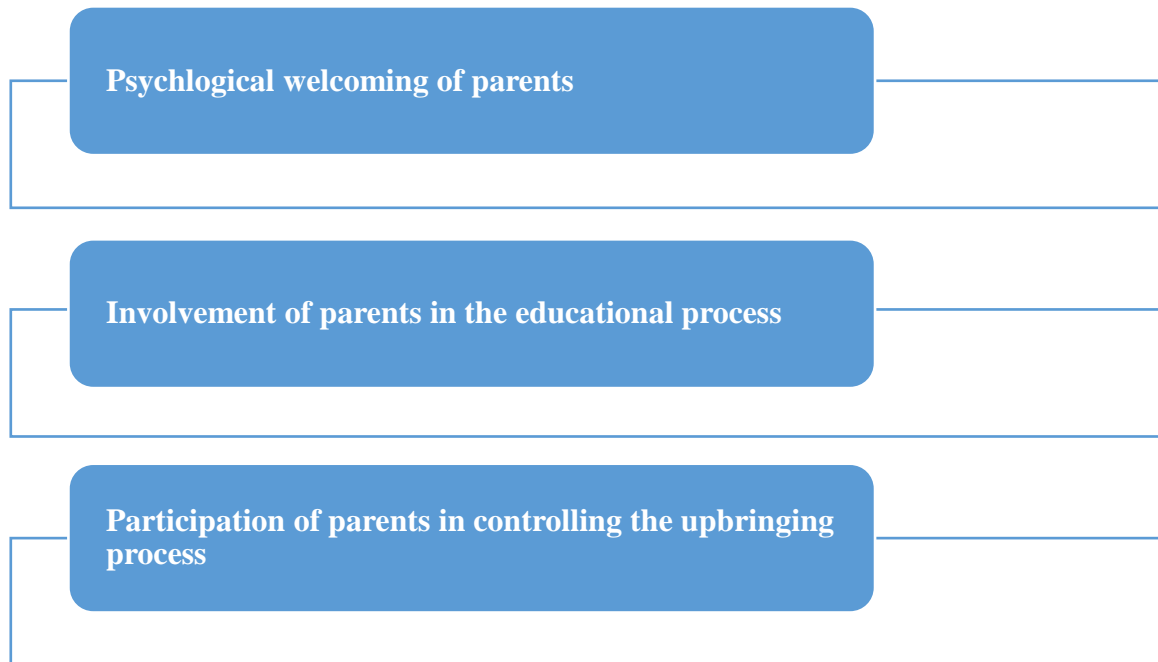

*Figure 1: Main directions of teacher-parents collaboration*

What children learn, whether physically, spiritually or morally during the first seven years of their lives, what they develop and shape will remain as a foundation for their later lives. Primarily, parents play a decisive role in creating prerequisites for the character of the child, in developing their willpower and their feelings and so on. Very often parents use such phrases as “Don’t be silly”, “You can’t do anything” and so on. This poor upbringing style, if it happens more often, has extremely negative consequences for the development of the child's personality. The consequences are known. Such children become timid, reserved and quiet.

Constantly criticising and emphasizing dissatisfaction, stopping a child's initiative lead to thoughts such as:

- “I’m not as smart and skillful as others!”;
- “I better look at how others do it”.

“A person is not born with fully developed self-consciousness”, writes psychologist Lyublinskaya. “They see themselves as a mirror reflection in opinions of other people”. Children start seeing themselves the way adults see them'. Parents need to be aware of this in order to contribute to painless transition from kindergarten to first grade. Adaptation to the new school conditions and requirements should rely on the positivity of the child, on what they can do even when we are not satisfied with their handiness or certain behavior. Only in this way can they develop, perceive and learn quickly. Parents need to be very familiar with the individual peculiarities of their children so that through their attitude towards them parents could contribute to the peace of the child to the fullest extent so that they are not afraid to be involved in class activities during lessons and extracurricular activities.

Creative work is possible only when one loves their job, when they consciously experience joy and see the benefit and need of it, when the work becomes the most important expression of their personality and talent. The need for meaningful and useful work is an important quality of man. There are many opportunities in the family's responsibilities to develop this quality in the child. The joy of something being accomplished is the beginning for developing active and strong characters (Popov, 2000). Thinking process of a person always starts with the questions: 'What is this?'; 'What is it made of?'; "Why is it made this way?" etc. Children try to answer these questions with action. They try and experiment in order to find out what is behind the secrets. Therefore, through their activity they gain valuable knowledge and life experience. Children learn in action. They soon start to realize that work is something different from game. They recognize and feel the value of their own selves. Work in the family becomes an important educational means for building the persistence, diligence, conscientiousness and other valuable traits needed at school. Life in the family offers favourable conditions for the creation of a valuable moral attitude in children. Through individual actions and reflections, children acquire knowledge and skills that gradually become their life experience and an acquisition that is important for the success of children in school. The child feels proud of being involved with adults when he or she successfully participates in various activities. It is important for every family to develop in children a proper attitude towards work. Children need to be aware that work is rewarding, learn to enjoy the successes and experience them. Only in this way will young first-graders have a desire for work, perseverance and enthusiasm for coping with school difficulties.

Before children can perform their work properly, they must learn to be independent. Independence provokes consciousness, gives the child security and raises self-esteem. In school they will experience what it means to study and work independently. Proper daily organization, followed consistently, contributes significantly to the formation of certain habits, i.e. the child to get used to the order and to develop time perception. Day mode is also significant for shaping the right behaviour. Order and discipline are key factors in overcoming school difficulties. Parents need to be interested in their child's school life (Popov, 2000). They need to find time to ask how their child's day went, what happened at school, whether they were tested or assessed, what the child's behavior was during the class and breaks, as well as what their attitude towards the actions of others is. At such moments, parents are obliged to lecture their children, make them think and show them the right way of doing things. Parents' assistance in the preparation of lessons and homework is particularly helpful for adaptation of their children in first grade. If the child due to the influence of the whole family pre-school upbringing is able to cope with the educational activity independently, has good discipline and relationships, there is no need for parental guidance and instructions. But if there is no pre-school preparation, they feel unnatural, school environment is still alien to them, their parents are obliged to help their children, to work with them and to prove to them that they can also achieve good results. Such children are timid and shy and they have a harder time getting used to school order and, therefore, it is more difficult for them to embrace the role of a student. However, with the right attitude of family and with the teacher's assistance, children quickly understand what they need to do and with more work and persistence, they quickly absorb and catch up with others. The attitude of adults towards the child as a future individual, considering the high level of education of the older generation and other conditions, influences the first-graders and makes them much more alert today and contribute to much richer prior knowledge. Training and educational work of pre-school institutions and the upbringing of the family contribute significantly to this. School attitudes are determined both by the student's character, by their requirements and capabilities and by the level of development in a given age range.

Family is particularly responsible because it has to prepare the child for school and, of course, support their successful start. In any case, through communicating and raising their child, parents strive to reach such level of the child's capabilities that will largely ensure successful performance of school requirements. Ensuring good physical development and health of the children is a particularly important and responsible task for the family (Popov, 2000). Going to school means a huge change for a child. They must have grown physically for many new demands and relative changes in the rhythm of their lives. Objective evidence of the stress caused to the child's body by school environment is that most children lose weight. By healthy diet, meaningful organization of total leisure time, by filling it with sufficient activities on fresh air, games, sports and with the help of established daily regime, parents will contribute to the training of the physical functions of the body.

However, physical changes are not the most important signs of school readiness. It is more vital whether their capabilities, skills, habits and attitudes needed for learning in school are properly developed. Although the goal of a first-grade teacher is to develop students' readiness to learn and their general attitude towards the tasks, these qualities must to some extent be acquired before going to school. This means that children need to take on appropriate tasks and solve them even when those tasks are difficult and whether they give them joy or not. More self-determination, persistence and a sense of obligation rather than a game are needed. The child should not be guided by their impulsive ideas and needs, but be able to control them and complete the task. The attitude towards the tasks includes the voluntary acceptance and diligent fulfillment of the goals set by the teacher. Small, regularly assigned tasks by the parents, as well as different ways of learning, memorizing and doing exercises willingly are important for building a conscious attitude towards the tasks. Such tasks help train conscious deliberate memorizing form of learning that is important for the child's adaptation to school (Popov, 2000; Rossiyskaya pedagogicheskaya entsiklopediya, 1993).

An important task for parents in order for their children to have a successful start at school is to awaken the joy for school and learning. The attention given to the older siblings' educational work, the curiosity of what is experienced at school, the superiority of school friends, these and other moments contribute to developing children's readiness and joyful expectation of learning at school. Parents should encourage the child's joy of school, reading and writing, as well as strengthen it and make it deeper. The child must already possess diligence, patience, order, discipline and other positive qualities if we want them to be good students. Parents need to help the child find their place in the team and learn to adapt to it. The teacher addresses the whole class and the child should feel part of it. However, often very few students get the chance to speak, thus self-control and modesty are required in such cases. In order to develop these qualities, parents must provide their children with sufficient opportunities to communicate with children of the same age outside of school. Admission to school is prepared through developing a number of skills and competences that need to be strengthened during the last pre-school year. The children should be relatively independent, get dressed by themselves, keep things in order, be organized and responsible when performing certain tasks given by parents. Proper speech is of great importance in order to be able to ask and answer questions in the class comprehensibly. The child must have acquired basic knowledge of life, nature, society and some objective human relationships. Of particular importance is their shared spiritual responsibility and life as a prerequisite for future success and for the further development of their personality (Terziev, Stoilova, 2019b-c).

#### 4. CONCLUSION

The relevance of this research in the field of education management, through directing to greater efficiency and better coordination between existing models of the Bulgarian education system, emphasises, by offering an institutional framework reform which execution is possible through the engagement of independent, competent and prepared individuals at the pre-school, primary and secondary levels of educational institutions, without whom no institutional system could by itself guarantee necessary efficiency. The measures proposed in this direction are ambitious, yet realistic, i.e. possible to implement in the immediate future through a constitutional amendment.

#### LITERATURE:

1. Terziev, V., Bankova, D., Dacheva, I. (2019). *Approaches in governing the educational processes in schools*. // XXII International Scientific Conference: The power of knowledge (11-13.10.2019), Kavala, Greece, Institute of Knowledge Management, Skopje, 34, 2019, 2, pp. 311-316, ISSN 1857-923X (for e-version), ISSN 2545 – 4439 (for printed version).
2. Terziev, V., Bankova, D., Dacheva, I. (2019a). *Theoretical underpinning of the problems related to pedagogical excellence and pedagogical creativity in the initial stage of school education*. // XXII International Scientific Conference: The power of knowledge (11-13.10.2019), Kavala, Greece, Institute of Knowledge Management, Skopje, 34, 2019, 2, pp. 411-417, ISSN 1857-923X (for e-version), ISSN 2545 – 4439 (for printed version).
3. Sechenov, I.M. (1952). *Izbrannae prazvedeniya*, T.1, M, 1952 (Сеченов, И.М. *Избранное произведения*, Т.1, М, 1952).
4. Pavlov, P.I. (1951). *Sabrani sachineniya*, T.3, M., 1951 (Павлов, П.И., *Събрани съчинения*, Т.3, М., 1951).
5. Andreeva, A., D. (1973). *Za ponyatiето „adaptatsiya“*, М, 1973 (Андреева, А., Д., *За понятието „адаптация“*, М, 1973).
6. Dichev, G.D. (1973a). *Metodologicheski i sotsialni aspekti za problema na adaptatsiyata na choveka*, S, 1973 (Дичев, Г.Д., *Методологически и социални аспекти за проблема на адаптацията на човека*, С, 1973).
7. Pavlov, P.I. (1951). *Dvadeset godishen opit za izuchavane na visshatanervna deynost*, М, 1951 (Павлов, П.И. *Двадесет годишен опит за изучаване на висшатанервна дейност*, М, 1951).
8. Zdravkova, S.T. (1978). *Razvitie na deystviyata za zvukov analiz v perioda na ogramotoyavaneto*, NO, 1978 (Здравкова, С.Т., *Развитие на действията за звуков анализ в периода на ограмотяването*, НО, 1978).
9. Popov, G. (2000). *Psihologiya na nachalniya uchenik*, S, 2000 (Попов, Г., *Психология на началния ученик*, С, 2000).
10. *Rossiyskaya pedagogicheskaya entsiklopediya*, (1993). М.: Bolyshaya ros. entsikl., 1993 (Российская педагогическая энциклопедия, М.: Большая рос. энцикл., 1993).
11. Terziev, V., Stoilova, M. (2019b). *Analysis of the system of school education. Strategy settlement process*. // 21 st International scientific conference: The teacher of the future, Budva, Montenegro, (07-09.06.2019), Institute of knowledge management – Skopje, Macedonia, 31, 2019, 6, pp. 1851-1857, ISSN 1857-923X (for e-version), ISSN 2545 – 4439 (for printed version).
12. Terziev, V., Stoilova, M. (2019c). *Experience of SWOT analysis in the system of the Bulgarian education*. // 21 st International scientific conference: The teacher of the future, Budva, Montenegro, (07-09.06.2019), Institute of knowledge management – Skopje, Macedonia, 31, 2019, 6, pp. 1887-1893, ISSN 1857-923X (for e-version), ISSN 2545 – 4439 (for printed version).

## EUROPEAN CONVERGENCE IN ECONOMIC GROWTH: THE ROLE OF INNOVATION AND PUBLIC POLICY

**Joana Costa**

*GOVCOPP, DEGEIT Universidade de Aveiro, Portugal  
joanacosta@ua.pt*

**Eva Pereira**

*DEGEIT Universidade de Aveiro, Portugal*

**Carlos Rodrigues**

*GOVCOPP, DCSPT Universidade de Aveiro, Portugal*

### **ABSTRACT**

*The debate on the critical factors to promote growth and convergence grasps the attention of both Academics and Policy Makers given its importance in the promotion of a sustainable and inclusive future. More than ever, this debate is central among the European regions, given the perceived differences in member-states. Innovation is widely acknowledged as a prosperity booster raising efficiency levels and promoting welfare. Despite the significant efforts performed in the field of European Innovation Policies, the presently there is evidence of heterogeneity in terms of both innovative performance and income generation, fragmenting inter-regional cohesion. The purpose of the article is to appraise the role of Innovation in the promotion of growth and income convergence among European regions, highlighting the changes brought up by the introduction of the Regional Innovation for Smart Specialisation (RIS3). The results evidence the poor achievements in terms of the acceleration of innovation practices and their scant effect in the promotion of convergence. Expectably, this will shed some light in the need for digging deeper in the appraisal of regional advantages and the allocation of more resources in the promotion of innovation ecosystems. The contribution is twofold: first towards the literature on convergence and second towards the empirical debate on the accuracy of present European Innovation Policies.*

**Keywords:** *Convergence, Growth, RIS3, Innovation, Regional Innovation Scoreboard*

### **1. INTRODUCTION**

Due to its effect on prosperity, the discussion of the foundations and policy boosters has gained momentum over the last decades (e.g. Solow, 1956; Romer, 1986; Lucas, 1988). Despite the multiplicity of approaches, endogenous growth theorists emphasised the importance of the human capital, and its quality in particular, to explain differences among countries while the constant returns to scale provided by non-human factors, as a consequence, investments in the stock of human capital became central in both the private and the public perspective given their spillover effects and their long term effectiveness. Moreover, these externalities shifted the model to increasing returns to scale (Romer, 1986; Lucas, 1988). Regardless the classification of growth as being exogenous or endogenous, the existence of positive externalities concerning human capital is accepted, explaining the higher growth of weaker economies compared to their stronger counterparts, who will lead to convergence; indeed the \_\_\_14 existence of diminishing marginal returns to the factors of production (Saad-Filho, 2010). The coexistence of two paces in terms of growth naturally erodes the differences between the rich and the poor, named as convergence, which can either be absolute or conditional (Sala-i-Martin, 1996; Young et al., 2008); in these frameworks, initial levels of income determine the speed at which countries converge. Accepting the premise of conditional convergence does reinforce the role of the Government in enhancing income generations, mostly in poor economies in which there is an



urgent need to take off. These, to some extent Keynesian approaches, strongly tie Government action in the Demand side to the expansion of the business cycle, leading to improvements in the job market and the market of goods. Under this transmission mechanism, weak economies will catch-up the rich, converging in similar levels of welfare. In this line, Government action plays a central role in attaining sustainable and inclusive growth (Bresser-Pereira, 2012).

## **2. LITERATURE REVIEW**

### **2.1. Growth Theories**

Neoclassical schools have dominated the debate concerning the linkage between institutions and policies and Growth, as popular examples one may identify the Solow-Swan exogenous growth theory, and Lucas and Romer in terms of endogenous growth theory. For the first, convergence is achieved based in technological progress and growth of labour force. As a consequence, output per worker is connected to the savings function, population growth, depreciations and capital intensity. To endogenous growth theorists, capital is seen as a twofold dimension of growth firstly physical and technological, directly connected to R&D and knowledge spillovers, not subject to diminishing returns to scale (Lucas, 1988; Romer, 1990). Investments in R&D lead to the increase of knowledge stocks (accumulated knowledge) which will continue to increase the ability to generate income in the future, due to its non-perishability working in the same vein as the savings function thus boosting growth (Perman and Stern, 2003). It is of worth mentioning that allocation of financial resources in Investments in R&D to generate higher stocks of knowledge, indeed cumulative capacity inside the firm, is strongly dependent to the political environment. As knowledge is a public good therefore not interesting to private initiative, unless there is a possibility to internalise the externalities. Due to its non-excludability and non-rivalry, knowledge production it, to hybrid neoclassical growth models only feasible encompassed by Public Policy (Levy and Spiller, 1994; Bassanini and Scarpetta, 2001; Ros, 2013).

### **2.2. Convergence**

Convergence has been of the spotlight for decades, it is rooted in the 50s in the works of Solow (1956, 1957) and Swan (1956), and these authors put as premise that the stock of capital was the only starting difference between economies, which were subject to decreasing returns to scale in physical capital. Three decades later, the debate on convergence focused in the empirical analysis of cross country evidence, proving in favour of absolute convergence (e.g. Baumol (1986), Barro and Sala-i-Martin (1995)). Later analysis encompassing absolute convergence with output per worker being constant in the steady state, led to conditional convergence (Barro, 1991; Mankiw et al., 1992). Under the premise of convergence, the poorest (with lower capital levels) will grow faster. Thus, from the former assumption, another one arises: all economies converge to a same long run steady state. This primordial concept is dubbed Absolute Beta convergence. According to Jordá and Sarabia (2014), due to its features, this framework is mostly suitable for income. Concerning results from studies built on the matter, using as a reference the same authors, it appears that not just there is little support for the existence of convergence, but also there are evidence from divergence and being this the future perspectives. However, the literature also points problems on the study of convergence built like this. Firstly, Barro and Sala-i-Martin (1990, 1992) and Sala-i-Martin (1996), point that economies differ in many structural characteristics. In fact, new growth models begin to assume non-convexity in production and/or externality arising from the accumulation of human capital, which allows divergence across time (Liargovas and Fotopoulos, 2009). Secondly, convergence may occur despite the absence of economic growth, when the variable under study relates to the quality of life (Royuela and García, 2013).

The later finding is particularly important for this study concerning the aims of the European Commission of Smart, inclusive and sustainable growth, a multidimensional perspective on growth. Maintaining the domain of income studies, the technological capacity, population growth and human capital are introduced as factors of distinction between economies as well as the origin for different steady states. An extended concept of convergence arises, the Conditional Beta convergence, implying that the poorest countries will have to converge faster to its own steady state (Sala-i-Martin 1996). Beta convergence is a necessary, although not sufficient condition for an alternative definition, Sigma convergence (Sala-i-Martin, 1996), which will be a reality if the dispersion of per capita income from the cross-country mean decreases over time Jorda and Sarabia (2014). This implies that countries lagging behind have to grow faster. Non sufficiency of  $\beta$ -convergence derives from the possibility of its observation along with  $\sigma$ -divergence, meaning this that the rate of growth of a poor country may be so high, that it surpasses initially richer nations. Perhaps for this reason Sala-i-Martin (1996) states that  $\beta$ - and  $\sigma$ -convergence need to be considered together. Highlighting income as a measure of wellbeing, most of the articles analysed opted for the Gross Value Added (GVA) or even the Gross Domestic Product (GDP) as a measure of income (Bivand and Brunstad, 2006; Jordá and Sarabia, 2014; Marchante and Ortega, 2006) and the most common result from this approach is the absence of convergence. Marchante and Ortega (2006) aim the comparison between different measure, for which purpose made use of the total personal income minus current grants (TPI) and gross personal disposable income (GPDI), both variables in per capita terms. These authors find absence of convergence for the per-capita GVA, despite of rejecting the hypothesis of no convergence when using TPI and GPDI, concluding that when analysing regional convergence, results may vary according to the chosen indicator of income. The case is even more pronounced when variables from the wellbeing domain are introduced. In a first moment, keeping income as a measure of wellbeing, “TPI and GPDI seem more relevant when analysing the economic welfare of the population in each region”, at least for Spain. Justifications for this phenomenon rely, on the one hand, on the territorial nature of GVA or GDP, which matches the region where it was generated, implying that mostly residential regions suffer from underestimation in relation to the actual population, due to the daily movement of the labour force to the regions of work, while the later benefit from overestimation. TPI and GPDI match, in turn, the total income of the households and private non-profit institutions regardless of the region of generation. On the other hand, GVA per se, doesn't allow understanding the effects of public-sector redistribution and it is, therefore, natural that it is associated to a higher degree of inequality. In addition, dispersion of GPDI is steadily lower than the TPI's, highlighting even more the role of public sector intervention through direct taxation, national insurance contributions and current grants. In a nutshell, it may be useful, for public policy evaluation purposes to compare GPDI, GVA and TPI results. Further work has introduced the measurement of convergence within social indicators. In this context, it is common to use SEN's approach of wellbeing as a starting point and the Human Development Index as an instrument (Jordá and Sarabia, 2014; Royuela and García, 2015). The traditional approach would, thus, involve three dimensions: living standards (income), health and education, being it regular to use them individually. However, it has been subject to criticism for not including equally important dimensions such as democracy, social cohesion, personal safety, environmental quality (Jorda and Sarabia, 2014). Liargovas and Fotopoulos (2009) recognize as well, the importance of infrastructures, crime rates, employment, quality and availability of public services and the price of goods as quality life factors interfering with wellbeing. Nonetheless, these same authors introduce the difference between the availability of resources and the actually advantage taken from them. There are other factors, already introduced in 1981 for Allardt, such as non-material conditions (social and cultural integration) and conditions in the domain of satisfaction (measurement of quality of life). The later may be

hindered by time constraints, availability and diffusion of information, skills needed to use new technologies and freedom. “Social inequalities today, are not based on income (as in the past), but on knowledge and information” (Liargovas and Fotopoulos, 2009). According to Noorbakhsh (2006), the concept of diminishing returns on the basis of the original conception of absolute convergence can be applicable with the same viability to educational and health indicators with some peculiarities. Indeed, it is assumed that investment returns in education and health diminish with the level of investment. In a country with low levels of primary education, relatively less investment is necessary to increase the mean years of schooling, meaning this that the returns for each unit of investment are higher. Jorda and Sarabia (2014), opt for the inclusion of the Economic Freedom of the World (EFW) Index as an explanatory variable, due to the positive relationship with human wellbeing, and particularly with income, found in previous literature (Gwartney and Lawson 2004). This variable is included as a measure of the quality of national institutions with respect to economic performance. In addition, these authors resort to public expenditures on health and on education as a percentage of the GDP, “as domestic determinants of the expansion of well-being”. Jorda and Sarabia (2014) include Trade as a percentage of GDP as an explanatory variable for income, reminding that the associated coefficient doesn’t generate consensus, some find it is positive, others that it has a negative effect. This is particularly important for EU studies as Trade is often used as a proxy for openness Noorbakhsh (2006). Foreign Direct Investment (FDI), in turn, is found to have no effect on income. Jorda and Sarabia (2014) finish their article concluding that international cooperation should be promoted. These two propositions melted suggest that international cooperation should not rely in financial aid, at least the way it has been made. Likewise, EU funding may not have the desirable outcomes.

According to Borensztein et al. (1998), FDI potentiates economic growth only when the host economy has enough absorptive capability of advanced technologies, which suggests the place to where effort should be applied. Royuela and García (2015) note that unemployment is a variable able to measure inefficiency within the economy, being inefficiency understood as wide differentials in its regions across or within regions. However, the authors don’t include this variable due to its high correlation with per capita GDP and disposable income. Despite of the chosen indicators, results point out that significant improvements in non-income dimensions on wellbeing may happen regardless of little advance in income, which unveils the relevance of its study. Monfort (2008) uses data from 1995-2005 from EU regions, analysing separately EU-15 and EU-27, in order to better identify convergence patterns in terms of GDP per capita that are supposed to be stronger for the recently joined members. This article finds convergence within EU region, warning that it should not be analysed by a single alternative and rather through complementarities within different instruments. Accordingly, the author finds convergence within the EU-15, which was undetected by summary measures. Moreover, it is advised to analyse the distribution dynamics as “indicators fail to capture movements that may be relatively small in statistical terms but are nevertheless of importance from a policy point of view”. Veugelers (2017), despite measuring only sigma-convergence for the Innovation Union Scoreboard (IUS), identifies a high dispersion between 2009-2015, being it worse between 2012-2015. This article highlights the lack of convergence concerning private sector innovation capacity, proxied by the Business sector R&D expenditures. Moreover, it is identified a lack of convergence in the workforce skills and public expenditure. Questions remained unanswered, as time has passed since 2005, including a crisis in-between, amenable to accentuate divergences, which means that results from Monfort (2008) may be outdated. Moreover, there is no detected pattern on the effect of IUS identified divergences into growth.

### 3. METHODOLOGY AND DATABASE CONSTRUCTION

The empirical analysis will rely in a purposeful database built based on the combination of the Regional Innovation Scoreboard, the Eurostat and the European Social Survey. The former is the main source of the indicators used to evaluate RIS3, while the second allowed filling the database with indicators whose presence within RIS editions was inconsistent. Macroeconomic data such as Gross Value added, Gross domestic product and population was collected from Eurostat. Only trust indicators came from European Social Survey. Aiming to understand if smart specialization strategies have enhanced regions innovations efforts to translate in growth, and if this growth promoted a more inclusive Europe through a catching up project, Regional Innovation Scoreboard variables were used to define the steady state of 152 regions within Europe<sup>1</sup>.

### 4. EMPIRICAL ANALYSIS AND ECONOMETRIC RESULTS

Considering a period from 2008 to 2018 (11 years), with two subdivisions, from 2008 to 2012 and 2014 to 2018, three models were respectively estimated, however only the entire sample is presented. Pooled OLS, Random and Fixed effects were all used as estimators, empirical testing has put in favour of the last. The main hypothesis under study was that Smart specialization have induced a structural break in 2008-2018 series, promoting regional convergence. Rejection is the outcome. Although there is a structural break in 2013, smart specialization strategies have not been able to contradict any latent divergence process among European Regions.

2008-2018	coefficient	p- value
C	13,06283	(0.000)
Lngdp1	0,2572379	(0.000)
Inv1	0,4684754	(0.000)
lnpop	-0.4496112	(0.000)
sw	-0.2511454	(0.000)
TE	0,5423938	(0.000)
LL	0,1336028	(0.024)
Trdmrk	0,1251561	(0.005)
EPO	-0,1790729	(0.000)
SMEcol	0,0919087	(0.001)
NRD	0,0756086	(0.002)
Design	-0,1359697	(0.000)
MPP	-0,1234342	(0.000)
Moderate	-0,030949	(0,047)
Strong	-0,0154089	(0,495)
Leader	-0,0310485	(0,243)
Obs	<b>1672</b>	
F	61,08	(0.000)
R-squared	within = 0.3784	<b>Id 152</b>
	between = 0.1626	
	overall = 0.1672	

*Table 1: Econometric Estimations / Source: Authors' computation*

<sup>1</sup> Details concerning exploratory analysis of variables, descriptive statistics and correlations were purposefully omitted, however they can be provided upon request, as well as the empirical testing to guarantee the validity of the econometric estimations.

Between 2008-2012, the coefficient associated with the initial per capita GDP is small but still negative and significant favouring the convergence hypothesis. This result is in accordance with recent literature. Signorelli (2019) finds real economic convergence for the whole period under study (1995-2016), noting, however, that there was a reduction on convergence intensity after 2008. Hüther (2019) states two different processes occurring in the EU right after the crisis: a divergence process when dividing the EU in North and South; and a strong convergence concerning eastern and western EU. This author states that without southern countries deeply in crisis, convergence process has not stopped during crisis for NUTS II regions but even considering the full sample, divergence was quickly replaced by convergence. As a result, when analysing the full period, there are no signs of convergence, on the contrary, the coefficient associated to  $\ln gdp1$  is positive. At this point and considering Sala-i-Martin (1994) statement that convergence within regional datasets is only found unconditionally, unconditional Beta convergence will be analyzed. Results obtained are strongly supported by literature in those well studied domains. For instance, human capital, either measured by Tertiary education or Lifelong learning evidences a positive effect on GDP, being the impact of the former around 4 times stronger considering the full period. This positive relation comes upon Lucas (1988) ideas, that distinguished two types of accumulated human capital: one accumulated through schooling and a specialized human capital, that he stated, would arise through learning-by-doing. Contrarily to Lopez-Rodriguez and Martinez-Lopez (2017), R&D expenditure in the business sector doesn't seem to have a significant relation with GDP in any model, even Public R&D expenditure is only significant between 2008 and 2012. Hidalgo and Gabaly (2013) state that investment in R&D at the firm level takes at least 2 years to become a patent application. This suggests some delay on the possible impact on growth. It makes sense for R&D expenditures, public or private, to have a lagged effect. Therefore, a lagged model is introduced. Entering on a less explored territory, the present work bespeak a positive impact of Community Trademark applications and SMEs collaborating for two models. In fact, considering the full period the increase of one unit on the normalized value of the indicator Community Trademark applications will increase per capita GDP by 12,52%, which is the strongest impact from the RIS indicators, only behind Tertiary education and Lifelong learning.

It is also important to highlight Employment in medium-high/high tech manufacturing and knowledge-intensive services. This indicator does not appear to have either negative or positive effect on growth. This insignificance, combined with R&D expenditure in the business sector absence of significance, may be interpreted as R&D intensive sectors as the source of missing relevance. Are the R&D intensive sectors with their educated workforce capable to convert innovation inputs, such as R&D expenditures in outputs?

Pontikakis, Chorafakis and Kyriakoua (2009) introduce an important concept: R&D productivity, research output per unit of input. Returns for increasing input are not constant. Institutional structures must be able to accommodate R&D. Moreover, enough accumulated knowledge should exist to convert expenditures in output. Global R&D is often used in comparisons between Europe and its competitors. Kokko, Tingvall and Videnord (2015), for instance, using only EU15 countries, find a positive effect of R&D on growth. However, this relation is less significant when comparing with other industrialized countries, especially the US. The authors justify these differences through a biggest share of private sector investment and stronger public-private relations in the US. A reason for these features to become an advantage may be related to the commercialization potential, which tends to be higher when private sector is involved (Foray et al., 2012). Baneliené and Melnikas (2020) extend the analysis finding a much higher impact of R&D on growth in well-developed EU economies.

At this point, the question that arises is if previous authors had included EU 27 countries, would they still find a significant effect? Szymańska and Zalewska (2018) state that the quantity of R&D is also a problem throughout Europe. Studying progress towards Europe 2020 for the year of 2014, these authors find in R&D the largest gap in relation to its target, 3% of GDP.

## 5. CONCLUSION AND POLICY RECOMMENDATIONS

The inclusion of the Regional Innovation Scoreboard indicators allowed to understand how little consolidated is the “European Innovation System” as there is no single indicator able to maintain its position throughout the different models, with the exception of Tertiary Education. Moreover, deep structural problems were found during analysis. SMEs have problems concerning commercialization innovations, at least, at an international level and being Europe a great opportunity to reach this level, a series of barriers concerning EPO application arise, making everything harder, more time consuming and costly. During the recession period it seemed that there was an additional effort in the promotion of efficiency and collaboration, which were not kept in the following period. Indeed, SME collaborating indicator has decreased its value. This is a strong indicator that smart specialization strategies have not left the paper, as there is a lot of emphasis on collaboration and several stakeholders relations. Perhaps one option to push conquer of the triple and quadruple helix is instituting in the economy the need to search for efficiency. A convergence effect arising on innovation performance only seems to happen from the Modest classification to the Moderate. However it is interesting to notice that European guidelines still do not emphasize variables with potential to undermine or stimulate policies effect, such as trust. In sum, any policy recommendation would relate to a stimulus on Lifelong learning, that has become more important than Tertiary Education, a more unified and less bureaucratic legislation at the EU level concerning patents, in order to shorten R&D expenditure effects as well. It is, however, important to mention that reverse effects were not considered in this study, which may result in overestimated coefficients, being it a limitation. Future studies may focus on crossed relations between variables in order to maximize policy efficiency. Much has been done considering the design and implementation of Smart Policies to erode the heterogeneities among European Regions, still, much more needs to be done. The present crisis is a strong challenge to the European construction, and, it seems that sustainable and inclusive recovery needs to rely upon the implementation of persistent and responsible innovation practices.

## LITERATURE:

1. Banelienė and Melnikas (2020), “Economic Growth and Investment in R&D: Contemporary Challenges for the European Union”, *Contemporary Economics*, Vol. 14 Issue 1. 38-57
2. Barro, R. J., & Sala-i-martin, X. (2003), *Economic growth*. Cambridge: The MIT Press (Vol. 80).
3. Bivand, R., and Brunstad, R. (2006), “Regional growth in Western Europe: Detecting spatial misspecification using the R environment”. *Papers in Regional Science*, 85(2), 277–297.
4. Bresser-Pereira, L.C. (2012), “Structuralist macroeconomics and the new developmentalism”, *Revista De Economia Política*, Vol. 32 No. 3, July/September.
5. Foray, D., Goddard, J. (2012), “Guide to Research and Innovation Strategies for Smart Specialisation (RIS 3)” European Union, DG Regions
6. Hidalgo, A. and Gabaly, S. (2013), “Optimization of prediction methods for patents and trademarks in Spain through the use of exogenous variables”. *World Patent Information* 35(2):130-140.

7. Jordá, V., and Sarabia, J. M. (2015), “International Convergence in Well-Being Indicators”. *Social Indicators Research*, 120(1), 1–27.
8. Levy, B. and Spiller, P., (1994), “The Institutional Foundations of Regulatory Commitment: A Comparative Analysis of Telecommunications Regulation”, *Journal of Law, Economics, and Organization*, 10, issue 2, p. 201-46.
9. Liargovas, P. G., & Fotopoulos, G. (2009), “Socioeconomic indicators for analyzing convergence: The case of Greece: 1960-2004”. *Social Indicators Research*, 93(2), 315–330.
10. Lopez-Rodriguez, J. and Martinez-Lopez, D., 2017. "Looking beyond the R&D effects on innovation: The contribution of non-R&D activities to total factor productivity growth in the EU," *Structural Change and Economic Dynamics*, Elsevier, vol. 40(C), pages 37-45.
11. Lucas, R.E. (1988), “On the mechanics of economic development”, *Journal of Monetary Economics*, Vol. 22 No. 1, pp. 3-42.
12. Mankiw, G., D. Romer, D. Weil, (1992) A Contribution to the Empirics of Economic Growth. *Quarterly Journal of Economics*, vol. 107, p. 407-437.
13. Marchante, A. J., and Ortega, B. (2006), “Quality of life and economic convergence across Spanish regions, 1980-2001”. *Regional Studies*, 40(5), 471–483.
14. Monfort, B. P. (2008), “Convergence of EU regions Measures and evolution Measures and evolution”. Working papers.
15. Noorbakhsh, Farhad, (2006), “International Convergence or Higher Inequality in Human Development?: Evidence for 1975 to 2003”, No RP2006-15, WIDER Working Paper Series, World Institute for Development Economic Research (UNU-WIDER).
16. Perman, Roger and Stern, David, (2003), “Evidence from panel unit root and cointegration tests that the Environmental Kuznets Curve does not exist”, *Australian Journal of Agricultural and Resource Economics*, 47, issue 3, p. 325-347.
17. Pontikakis, Chorafakisb and Kyriakoua, (2009), “The Question of R&D Specialisation: Perspectives and policy implications”. European Commission.
18. Royuela, V., and García, G. A. (2013), “Economic and Social Convergence in Colombia”. *Regional Studies*, 49(2), 219–239.
19. Romer, P.M. (1986), “Increasing return to scale and long-run growth”, *Journal of Political Economy*, Vol. 94 No. 5, pp. 1002-1037.
20. Romer, P.M. (1990), “Capital, labour and productivity”, *Brooking Papers on Economic Activity*, Vol. 1990, pp. 337-367.
21. Saad-Filho, A. (2010), “Growth, poverty and inequality: from washington consensus to inclusive growth”, Department of Economic and Social Affairs, DESA Working Paper No. 100ST/ESA/2010/DWP/100.
22. Sala-I-Martin, X. (1996), “Regional cohesion: Evidence and theories of regional growth and convergence”. *European Economic Review*, 40(6), 1325–1352.
23. Swan, T. W., (1956) *Economic Growth and Capital Accumulation*. *The Economic Record*, vol. 32, p. 334-43.
24. Szymańska, A.; Zalewska, E., (2018), “Towards the goals of the Europe 2020 strategy: Convergence or divergence of the European Union countries?”, *Comparative Economic Research*, De Gruyter, Warsaw, Vol. 21, Iss. 1, pp. 67-82.
25. Solow, R.M. (1956), “A contribution to the theory of economic growth” *Quarterly Journal of Economics*, Vol. 70, pp. 65-944.
26. Veugelers, R. (2017) ‘Countering European Brain Drain’, *Science*, 356 (6339): 695-696.
27. Young, A., Higgings, D. and Levy, D. (2008), “Sigma Convergence versus Beta Convergence: Evidence from U.S. County-Level Data” *Journal of Credit Money and Banking*, Vol.40 No. 5.

## QUALITY OF LIFE AND SOCIO-DEMOGRAPHIC FEATURES OF WOMEN WITH BREAST CANCER PATIENTS

**Diana Tsiring**

*Tomsk State University, Tomsk, Russia  
Chelyabinsk State University, Chelyabinsk, Russia  
l-di@yandex.ru;*

**Irina Ponomareva**

*Tomsk State University, Tomsk, Russia  
Chelyabinsk State University, Chelyabinsk, Russia  
Ivp-csu@yandex.ru*

**Evgeniya Evstafeeva**

*Tomsk State University, Tomsk, Russia  
Chelyabinsk State University, Chelyabinsk, Russia  
evgeniy-eg@mail.ru*

**Marina Mironchenko**

*Tomsk State University, Tomsk, Russia  
South Ural State Medical University, Chelyabinsk, Russia  
thoraxhir@mail.ru*

### **ABSTRACT**

*In Oncology the assessment of a patient's quality of life is important for conducting and determining the effect of maintenance therapy. The quality of life study makes it possible to evaluate the effectiveness of treatment for a specific patient and use the data obtained to correct the treatment program. The study involved 186 women aged 26 to 80 years (Ad = 57, Min = 26, Max = 80) living in Russia. To study the quality of life of women with breast cancer, we used the SF-36 questionnaire recommended by the international Protocol (36-ItemShort-FormHealthSurvey). Reduced values of quality of life indicators were found in women with breast cancer compared to other women in the population. The reduced quality of life is a consequence of women's illness, the corresponding lifestyle associated with the disease. The overall quality of life indicator is predictive and allows you to predict the General trends of changes in the condition of patients during treatment. The features of quality of life indicators (PF, GH) in women with breast cancer with different socio-demographic indicators were revealed: employment and residence characteristics.*

**Keywords:** *oncology, oncopsychology, breast cancer, quality of life, socio-demographic characteristics*

### **1. INTRODUCTION**

Today, in developed and developing countries, malignant neoplasms are one of the main causes of death and disability of the working population. Socio-economic losses are associated with high costs of treatment, social security, preventive and rehabilitation measures. Often irreversible disability. One of the leaders among all malignancies is breast cancer. This is a serious medical and social disease. According to world statistics, more than 1.5 million women have been diagnosed with breast cancer, and about 400 thousand cases are fatal. Despite improved methods of diagnosis and treatment of breast cancer, the survival rate remains low. The prevalence of this cancer is wide in all developed and developing countries. The disease affects all segments of the population, of different social status and age.



In Russia, breast cancer accounts for 21.1% of the incidence of malignant neoplasms in women. The cumulative risk of breast cancer increased from 4.81 to 6.02 from 2007 to 2017. Every year, the Russian Federation loses more than 22,000 women, many of whom were of reproductive age (according to the FSBI NMRRC of the Ministry of Health of the Russian, 2017). We must not lose sight of the social vulnerability of women facing a deadly disease. State programs (for example, breast cancer screening), national projects with large financial and intellectual resources aimed at modernizing technologies, methods of diagnosis and treatment of breast cancer, reduce mortality. Modern medicine has developed many effective ways to treat this disease. At the same time, an important aspect is not only the preservation of life, good health, but also the achievement of a better quality of life for patients.

## **2. LITERATURE REVIEW**

In Oncology, the assessment of a patient's quality of life is important for conducting and determining the effect of maintenance therapy (Ionova et al., 2017). The quality of life study makes it possible to evaluate the effectiveness of treatment of a specific patient and use the data obtained to correct the treatment program (Ionova, 2019; Afanasieva, 2010). In addition, quality of life research plays an important role in evaluating the effectiveness of programs and reforms in health care and public health. There is no unambiguous interpretation of the concept of quality of life. Just as there are no specific criteria for assessing the quality of life. According to the recommendations of the world health organization, quality of life should be considered as "the perception of individuals in the context of their culture and value system, as well as their personal goals, standards and interests" (world health organization, 2020). The quality of life is the degree of comfort of a person within themselves and in society (Afanasieva, 2010). The quality of life is considered as an integral characteristic of the physical, mental and social functioning of a healthy and ill person, based on their subjective perception (Novik, Ionova, 2017). This concept of quality of life reflects the key categories underlying the concepts of human health, its physical, psychological and social functioning (Ionova, 2019).

In addition, the quality of life research methodology provides a new reliable and informative way to determine the key parameters of human well-being (Ionova, 2019). Based on international standards, it offers a wide range of opportunities to measure key aspects of a person's life and study changes in their physical, psychological and social functioning based on their self-assessment (Novik, Ionova, 2012). The uniqueness of the quality of life research approach lies in the possibility of a full-scale description of the impact of the disease and treatment on all components of the patient's functioning (Ionova, 2019). In modern medicine, the treatment of breast cancer is a complex problem. Therefore, the search for additional criteria for the effectiveness and safety of treatment is very relevant (Dyachenko, Kovalenko, 2013). The study of the quality of life of women with breast cancer will determine the factors that will contribute to improving their lives and have significance for the development of effective treatment approaches.

Despite the fact that modern medicine can cure breast cancer or achieve long-term remission, the quality of life of women remains unsatisfactory (Dyachenko, Kovalenko, 2013). The consequences of surgery in the treatment of breast cancer have a permanent traumatic effect on the psyche of women. There is a need to develop criteria that help the doctor in determining the treatment strategy, and patients-in choosing the most appropriate treatment option (Dyachenko, Kovalenko, 2013). The results of the study can serve as a basis for developing recommendations for working with patients who are forced to live in extreme conditions of breast cancer treatment and its consequences.

Quality of life is an indicator of the subjective perception of individual well-being in life as a whole, as well as individual circumstances of a person. It is the achievement of a certain level of well-being of women with breast cancer, in addition to survival and maintaining performance, that should be the ultimate goal of doctors, psychologists and social workers. In our opinion, it is particularly important to assess the quality of life of women from the moment of diagnosis of breast cancer and for five years, that is, with coverage up to the treatment period, the treatment itself and the rehabilitation period. Domestic and international experience in the study of the quality of life of women with breast cancer shows that this method is promising, allowing the oncologist to form additional ways of rehabilitation within the framework of complex therapy, maintaining the previous lifestyle and forming a sufficiently high social activity (Dyachenko, Kovalenko, 2013). Thus, the purpose of this study was to study the socio-demographic characteristics and quality of life indicators of women with breast cancer.

### **3. RESEARCH METHODOLOGY**

#### **3.1 Research methods**

The methods used were questionnaires, surveys, methods of descriptive statistics, Mann-Whitney U, t-criterion for a single selection.

#### **3.2. Characteristics of the sample**

The study involved 186 women aged 26 to 80 years (Med = 57, Min = 26, Max = 80) living in Russia. Level of education: 56.8% of women have secondary vocational education, 35.9% - higher education, 7.3% - General secondary education. Married women-61.5%, working women-51.4 %, non-working women-48.6%. The average income level is 63.1% of women, below average-16.6%, low-9.1%, above average-7%, critically low-4.3%. The entire sample of women was diagnosed with breast cancer within 6 months. All the patients had a luminal type of tumor. The most common was a moderately differentiated variant of invasive breast carcinoma, 54.5% of cases, high-grade cancer was found in 31.8% of cases, and one case of low-grade cancer and Gx. When distributed by location, patients with left breast cancer were more common, 63.6% of cases. Considering that the study included patients who had undergone surgery in terms of radical treatment, the distribution by stages is as follows: Stage I-59%, stage II-22.7%, stage III-13.6%. 40% of women are rural residents, 60 % live in the city.

#### **3.3. Method**

The SF-36 questionnaire recommended by the international Protocol (36-Item Short-Form Health Survey) was used to study the quality of life of women with breast cancer. The questionnaire can be used to identify violations of the patient's physical, psychological and social functioning. The results of the questionnaire are presented in the form of scores on 8 scales, compiled in such a way that a higher score indicates a higher level of quality of life. The following indicators are evaluated:

1. General health (General Health, GH).
2. Physical functioning (PF).
3. Role-based functioning due to physical state (Role-Physical Functioning, RP).
4. Role-based functioning due to an emotional state (Role-Emotional, RE).
5. Social functioning (SF) is defined by the degree to which a physical or emotional state restricts social activity (communication).
6. intensity of pain (Body Pain, BP).
7. Vital activity (Vitality, VT).
8. Mental Health (MH).

#### 4. FINDINGS AND DISCUSSION

Through questionnaires and psychological diagnostics of quality of life indicators in women with breast cancer, average values of indicators and standard deviation were obtained (table 1).

SF-36 scales	M	σ
Physical functioning (PF)	61,86	27,12
Role-based functioning physical state (RP)	34,58	42,55
Pain intensity (BP)	54,36	31,77
General health status (GH)	46,16	32,9
Vital activity (VT)	48,53	27,80
Social functioning (SF)	59,85	27,7
Role functioning due to emotional state (RE)	38,36	42,09
Mental health (MH)	46,84	26,83

*Table 1: Average values of quality of life indicators in women with breast cancer (N=186)  
(Source: Authors)*

As can be seen from table 1, the average values of quality of life indicators in women with breast cancer differ significantly from the maximum indicators (100) of quality of life (according to SF-36). Further, to determine the characteristics of the quality of life of women with breast cancer, it is necessary to make a statistical comparison of the quality of life of women with breast cancer with population indicators. Population indicators were obtained by the research team in the course of a multicenter study of quality of life "MIRAGE" on a sample of 3400 respondents (2405 women, 939 men) from 5 centers in Russia (Amirdzhanova, Goryachev, Korshunov, Rebrov, Sorotskaya, 2008). Before comparing the quality of life indicators, we standardized the average values, and then compared them with the average values of the standardized population indicators of quality of life (QOL) SF-36. Table 2 shows standardized population - based indicators of women's quality of life (Amirdzhanova et al., 2008) and quality of life indicators for women with breast cancer (table 2).

Subscales questionnaire SF-36	Normalized indicators of the population sample (n=2405), mean values and standard deviation	Indicators of women with breast cancer (n=186), mean values and standard deviation
Physical functioning (PF)	49,42±9,88	44,62± 17
Role-based functioning physical state (RP)	49,32 ±10,03	43,99±10,76
Pain intensity (BP)	49,39±9,97	45,46±10,04
General health status (GH)	49,49±10,02	45,5±10,03
Vital activity (VT)	49,34±10,03	45,81±11,83
Social functioning (SF)	49,36±9,84	47,36±12,09
Role functioning due to emotional state (RE)	49,11±10,07	46,98±12,65
Mental health (MH)	48,92±10,12	44±13,44

*Table 2: Comparison of normalized average quality of life indicators for women with breast cancer with standardized population indicators SF-36  
(Source: Authors)*

To identify statistical differences between standardized indicators of quality of life in women with breast cancer and standardized population indicators, we used a single-sample t-test that allows us to compare the value of distributions with a fixed value (population indicators). The results of the comparative analysis are shown in table 3.

	t	p
Physical functioning (PF)	-3,846	0,001
Role-based functioning physical state (RP)	-6,762	0,001
Pain intensity (BP)	-5,333	0,001
General health status (GH)	-5,421	0,001
Vital activity (VT)	-4,069	0,001
Social functioning (SF)	-2,259	0,025
Role functioning due to emotional state (RE)	-2,293	0,023
Mental health (MH)	-4,993	0,001

*Table 3: Results of comparison of quality of life indicators for women with breast cancer and population quality of life indicators  
(Source: Authors)*

Comparing the standard indicators of the quality of life questionnaire with data obtained from a sample of women with breast cancer, we found significant differences at a high level of significance for all SF-36 scales. Physical functioning (PF) in women with breast cancer was statistically lower ( $p=0.001$ ) than in the population sample of women. Most likely, this is due to the limited health capabilities of sick women. Limited physical activity, reduced volume of daily physical activity is a consequence of the disease and the course of the disease. Role-based physical functioning (RP) is related to the role of physical problems in limiting life activity. In women with breast cancer, this indicator is significantly lower than in the female population ( $p=0.001$ ). Women with breast cancer are more likely to report that problems related to their health limit their ability to function. Breast cancer as a disease imposes restrictions on women's performance of work or daily responsibilities. The pain syndrome (HR) experienced by women with breast cancer is significantly more intense and affects the performance of normal physical activity during the last month at the time of psychodiagnosis ( $p=0.025$ ). They experience intense pain that limits their physical activity and affects their quality of life. At the time of the psychodiagnosis, women with breast cancer assessed their own health status (GH), treatment prospects, and how they resisted the disease statistically worse than women in the population sample ( $p=0.001$ ). Women with a cancer diagnosis are less likely than women in General to feel full of strength and energy, that is, viable (VT) ( $p=0.023$ ). They are more likely to experience a state of fatigue and decreased activity. Social functioning (SF) women with breast cancer are subjectively rated lower than other women in the population ( $p=0.001$ ). They are less satisfied with the level of their own social activity, for example, communication with friends, family, or in a team. Their social contacts are reduced due to poor health. Role-based

emotional functioning (RE), which involves assessing the degree of influence of an emotional state on the performance of work or normal daily life, is statistically lower in women with breast cancer ( $p=0.001$ ). This indicates that the emotional state of cancer patients limits their daily activity. Psychological health (MH) as an integrative indicator of positive emotions is statistically lower in women with breast cancer ( $p=0.001$ ). More time women with cancer diagnosis feel anxiety, experience depressive emotions, psychological distress. So, a comparative analysis of standardized indicators of quality of life showed that the quality of life of women with breast cancer is statistically lower than that of women in the population. This result requires attention from social and psychological services, due to the fact that the overall quality of life indicator is linked to the survival forecast (Coates A., Gebiski V., Signorini D. J., 1992). Next, we studied the quality of life indicators in women with breast cancer with different socio-demographic characteristics. Through questionnaires, we obtained such socio-demographic data as the level of education, marital status, presence of children, characteristics of residence, income level, employment. Table 4 shows the results of a comparative analysis of quality of life indicators for women with breast cancer with different socio-demographic characteristics using the Mann-Whitney U.

SF-36 quality of life indicator	Socio-demographic characteristics of women with breast cancer (N=186)		Mean rank	U	p
PF – Physical functioning	Employment	Work	100,35	3398	0,028
		Not work	83,18		
GH – General health status	Special characteristics of livingg	Home to one	106,8	2154	0,044
		Lives with family and / or other relatives	87,46		

*Table 4: Comparative analysis of quality of life indicators in women with breast cancer with different socio-demographic characteristics  
(Source: Authors)*

Women with breast cancer who work, including informally or part-time, rate their physical activity higher (PF) than women with breast cancer who do not work (are retired, Housewives). The volume of daily work, which is not limited by the state of health, is higher in working women ( $p=0.028$ ). Women with breast cancer who live alone rate their own health status, treatment prospects, and disease resistance (GH) higher than women with cancer who live with family and / or other relatives ( $p=0.044$ ). These results are probably due to the fact that a woman who lives alone devotes more time to her own health and self-care. Thus, differences were found in some indicators of quality of life in women with breast cancer on such socio-demographic characteristics as employment and residence characteristics. There were no differences in quality of life indicators for other socio-demographic characteristics (level of education, marital status, income level, presence of children).

Data shows that the quality of life of women diagnosed with breast cancer does not depend on their marital status, the presence or absence of children, the level of education and income of these women.

## 5. CONCLUSION

Thus, the study revealed reduced values of quality of life indicators in women with breast cancer compared to the rest of the population. The reduced quality of life is most likely a consequence of women's illness, the corresponding lifestyle associated with the disease. The overall quality of life indicator is predictive and allows you to predict the General trends of changes in the condition of patients during treatment. In previous studies, it was found that patients with low quality of life indicators initially have worse indicators at the end of treatment, which indicates the possibility of predicting the course of breast cancer based on quality of life indicators, both before and after treatment (Dyachenko, Kovalenko, 2013). In addition, the data obtained on the quality of life of women with breast cancer should be analyzed in combination with clinical parameters and used as an additional source of information about the effect of maintenance therapy and antitumor treatment in General. We also identified features of quality of life indicators (PF, GH) in women with breast cancer with different socio-demographic indicators: employment and residence characteristics. Working women with breast cancer are characterized by higher physical activity, which is not limited by their health status. Women with breast cancer who live alone have a higher overall health status. It can be assumed that these socio-demographic characteristics and quality of life indicators are associated with the course of the disease and recovery, and may act as factors of survival. This requires close attention and further study. Also, the study of the quality of life of women with breast cancer can become the basis for individual programs of psychological rehabilitation.

**ACKNOWLEDGEMENT:** *The research has been conducted due to the grant provided by the Russian Science Foundation (project No.19-1800426).*

## LITERATURE:

1. Alan S. Coates , Hürny C., Peterson H., Bernhard J., Castiglione-Gertsch M. et al. (2000). *Quality-of-Life Scores Predict Outcome in Metastatic but Not Early Breast Cancer*. Journal of Clinical Oncology.
2. Amirdzhanova V. N., Goryachev D. V., Korshunov N. I., Rebrov A. P., Sorotskaya V. N. (2008). *Population indicators of quality of life according to the SF-36 questionnaire (results of a multicenter study of quality of life "Mirage"*. Scientific and practical rheumatology.
3. Caloudas S.G. (2011). *Personality, coping, and quality of life in early stage breast cancer survivors*. ProQuest Dissertations & Theses A&I 20.04.2020 from <http://search.proquest.com/docview/519152515?accountid=175014>
4. Coates A, GebSKI V, Signorini D et al. (1992) *Predictive value of quality of life indicators in chemotherapy for advanced breast cancer*. Australian New Zealand Breast Cancer Research Group. J Clin Oncol 10.
5. Colette L, van Andel G, Bottomley A. et al. (2004). *Is baseline quality of life a useful tool for predicting survival with hormone-refractory prostate cancer? A pooled analysis of three studies of the European Organisation for Research and Treatment of Cancer Genitourinary Group*. Journal of Clinical Oncology.
6. Dyachenko V. G., O A. S., Kovalenko V. L. (2013). *Prospects for studying the quality of life of patients with breast cancer (literature review)*. Eastern medical journal. 22.04.2020 from <https://cyberleninka.ru/article/n/perspektivy-izucheniya-kachestva-zhizni-bolnyh-rakom-molochnoy-zhelezy-obzor-literatury>

7. Ionova T. I. (2019). *The Significance of quality of life research in modern healthcare*. Quality and life.
8. Ionova T. I., Nikitina T. P., Novik A. A., Snegovoy A.V. (2017). *Practical recommendations for assessing the quality of life in cancer patients*. Malignant tumors: practical recommendations of RUSSCO.
9. Musayeva N., Dykhno Yu., Slonimskaya E. (2005). *Quality of life of breast cancer patients*. Siberian Journal Of Oncology.
10. Novik A. A., Ionova T. I. (2012). *Guide to the study of quality of life in medicine*. Moscow: publishing house of the Russian Academy of medical Sciences.
11. Tsiring D., Evstafeeva E., Ponomareva I., Sizova Y. *Subject and personal particularities of women having various stages of breast cancer*. Electronic Journal of General Medicine. 20.04.2020 from <https://doi.org/10.29333/ejgm/112266>

## **EU TRADE RELATIONS WITHIN THE CONTEXT OF BREXIT (FOCUSING ON EU27 – UNITED KINGDOM RELATIONS)**

**Zuzana Kittova**

*University of Economics, Faculty of Commerce, International Trade Department  
Dolnozemska cesta 1, Bratislava, Slovakia  
zuzana.kittova@euba.sk*

**Simona Krivosudska**

*University of Economics, Faculty of Commerce, International Trade Department  
Dolnozemska cesta 1, Bratislava, Slovakia  
simona.krivosudska@euba.sk*

### **ABSTRACT**

*In connection with the UK's withdrawal from the EU, year 2019 brought about numerous discussions on the future set of the EU27 – UK relations and pending consequences. The aim of this paper is to assess changes in the EU trade relations within the context of Brexit (focusing on the EU27 – United Kingdom relations). We analyzed the development of the EU27 – UK trade in goods since 2012. By applying mathematical-statistical methods we quantified changes in the intra- and extra-EU trade. We demonstrated by calculating the complementarity index and trade intensity indexes that the EU27 countries and the United Kingdom are natural and closely interrelated trading partners. Introducing trade barriers would therefore adversely interfere with trade flows and lead to losses on both sides.*

**Keywords:** *Trade, Brexit, European Union*

### **1. INTRODUCTION**

After 43 years membership in the block, British inhabitants decided to leave the EU in a referendum in June 2016. The United Kingdom (UK) was the world's sixth largest economy in 2018 (World Trade Organization, 2019), wishing to regain its sovereignty and control over its own economy. Former Prime Minister D. Cameron stated immediately after the result of the referendum that Britain was stronger, safer and more prosperous in the EU. The British decided to take another path he was not able to identify with, therefore he resigned as Prime Minister (The New York Times, 2016). The uncertainty surrounding the Brexit lasted for more than two years since the activation of Article 50 of the Treaty on European Union (EU). The UK left the EU on 31 January 2020. Transitional period until December 2020 has begun during which the UK remains a member of the EU single market and the EU and the UK should negotiate their future relations including trade relations. The outcome of negotiations will be the determining factor for future trade development between the EU27 and the UK.

### **2. LITERATURE REVIEW**

There are numerous analysis aiming to predict the economic impact of Brexit. Most of them focus on the effect of Brexit on the UK (e.g. Make UK, 2019; HM Government, 2018; RAND Corporation, 2017). On part of the EU, the literature either examines the perspective of the overall EU trade relations (e.g. Kaš'áková et al., 2019; Drieniková, 2016; Ružeková - Krivosudska, 2019; Kittová, 2020; De Ville – Siles-Brugge, 2019; Smith, 2019; Cierco, 2013), or it deals with the impact of Brexit on the selected sectors or countries of the EU. For example, according to Econpol Europe (2017), the European Network for Economic and Fiscal Policy Research, tariff cuts and EU standards harmonization have had a clearly positive impact on the EU27 and the UK trade relations. Since 2000 till 2014, EU27 imports of goods from the UK increased by almost 65% and imports of services by 88%. The UK imports of goods from the



EU27 countries increased by more than 18% and of services by 60%. According to this study, applying trade barriers after the Brexit may cause a significant decrease in trade with goods and services between these trading partners. The Bertelsmann Foundation (2019) evaluated the impact of a soft and a hard Brexit on productivity, margins, product variety and welfare across European countries and regions. They found that the Brexit would have a significant impact on both the UK and the EU economies. According to this study, the hard Brexit could lead to annual welfare losses of 57 billion EUR in the UK and about 40 billion EUR in the other EU countries. The soft Brexit would substantially mitigate these losses. The European Committee of the Regions (2018) focused on assessing the impact of the UK's withdrawal from the EU on regions and cities in the EU27, taking into account the six key economic sectors of the EU27, namely transport vehicles, machinery, electronics, textile and furniture, vegetables, foodstuffs and wood, chemicals and plastics. According to the study, transport vehicles are exported most from Germany, Romania and France. Machinery is exported to the UK mainly by Germany and Italy. Electronics is dominated by the Slovak Republic, Czech Republic, Romania. Textiles and furniture are mainly exported from Italy, Portugal and Bulgaria. The vegetables, food and wood sector is dominated by Greece and France and the chemical and plastic sector by France and Germany. As follows from the overview, the studies about Brexit are partial, focusing more on the impacts on selected EU countries or sectors. Most studies focus on implications to the UK.

### 3. METHODOLOGY

The aim of the paper is to assess changes in the EU trade relations within the context of Brexit (focusing on the EU27 – United Kingdom relations). We analyzed the development of the EU27 – UK trade in goods since 2012. By applying mathematical-statistical methods we quantified changes in the intra- and extra-EU trade. The results are presented in graphical form. Further we used the trade intensity index and the trade complementarity index. Although these indices were originally compiled to estimate the potential for positive effects of trade integration (the higher is the trade intensity and trade complementarity of countries, the larger is the potential for positive effects of their integration), we believe that they can be also used to express positive effects of maintaining preferential trade relations. If the partners are able to increase the trade intensity and trade complementarity to a high level during the integration it makes sense for them to maintain mutual preferential trade relations. In such conditions, future positive trade effects for the participating countries may be expected.

**The Trade Intensity Index (TII)** is used to assess trade values between two countries, i.e. whether they are larger or smaller than it could be expected based on their position in the world economy. TII is determined as the share of exports of country *i* to country *j* on total exports of country *i* to the world, divided by the proportion of total world exports to the country *i* to the total value of world exports (World Bank, 2010).

Trade Intensity Index (TII) is calculated as:

$$TII_{ij} = \frac{(x_{ij}/X_{it})}{(x_{wj}/X_{wt})} \quad (1)$$

where:

$x_{ij}$  represents the value of exports from country *i* to country *j*;  
 $X_{it}$  represents the value of the *i* country's total exports to the world;  
 $x_{wj}$  represents the value of total world exports to country *j*;  
 $X_{wt}$  represents the total value of world exports.

TII reaches a value between 0 and  $+\infty$ . If the index value is higher than 1, the country  $i$  exports to country  $j$  relatively more than the world on average. This is an intensive trade relationship. If the index equals to 1, the share of country  $j$  on country  $i$  total exports is at the level of global exports to the country  $j$ . If the value is lower than 1, the intensity of trade is lower than expected considering the importance of the economy in world trade (World bank, 2013).

**The Trade Complementarity Index (TCI)** shows the extent to which country's exports to a partnering country coincide with the partnering country imports from the exporting country. The value of the index indicates if two countries are ideal trading partners or perfect competitors. The high value of the index shows that countries could benefit from free trade (World bank, 2010).

The Complementarity index defined as:

$$TCij = 100 \times \left[ 1 - \frac{|m_{ik} - x_{jk}|}{2} \right] \quad (2)$$

where:

$x_{jk}$  represents the share of the product  $k$  in the country's total export  $j$ ;

$m_{ik}$  represents the share of product  $k$  in the country's total import  $i$ .

TCI reaches a value from 0 to 100. If the index is equal to 100, the share of each country's exports and imports is absolutely the same, so countries are ideal trading partners. Despite the high value of the complementarity index, countries may not be ideal trading partners because of geographical distance or different modes of transport and transaction costs. If the index value is 0, no goods are exported or imported between countries and the countries are perfect competitors (World bank, 2013). The paper mainly used secondary sources of information. The Eurostat and International Trade Map databases were used to gain data for the calculation of the trade intensity and the complementarity indexes.

#### 4. RESULTS AND DISCUSSION

The trade in goods development of EU member states (EU27) with the UK is described in Figure 1.

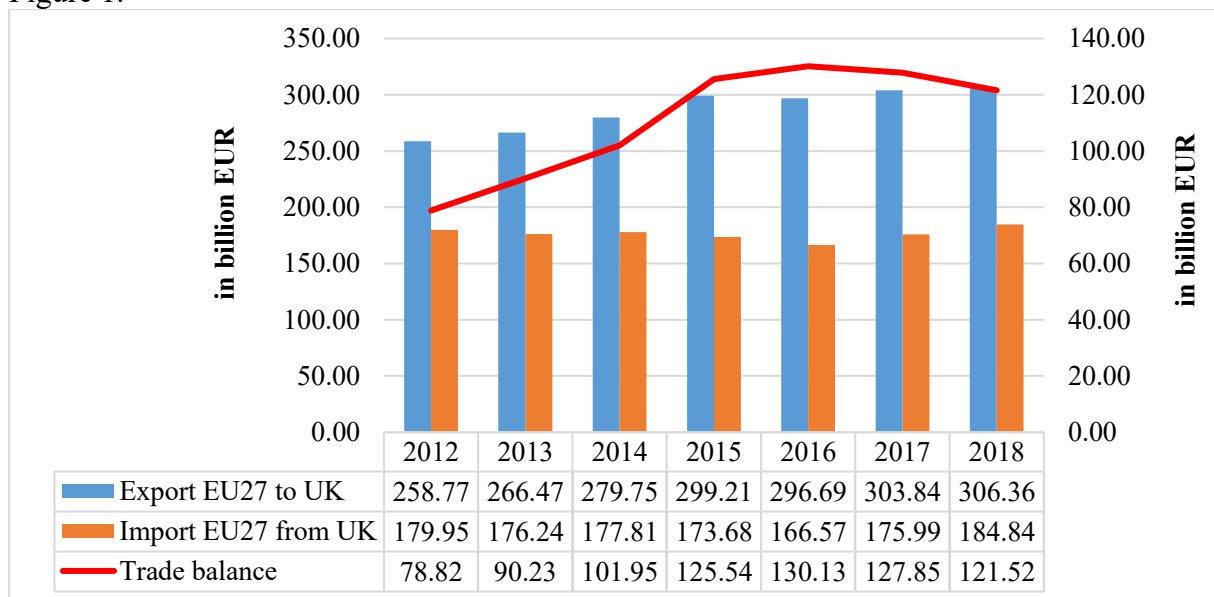

Figure 1: EU27 development of exports and imports with the UK in 2012 – 2018 (in billion EUR)

(Source: own calculation based on ITC Trade Map 2019)

As it can be seen, the EU27 exports to the UK increased from 258.77 billion EUR in 2012 to 306.36 billion EUR in 2018 which represents an increase of more than 18%. The import increased by almost 3% from 179.95 billion EUR in 2012 to 184.84 billion EUR in 2018. The EU27 trade balance with the UK was active throughout the period under review and it increased by more than 54% to 121.52 billion EUR in 2018.

#### 4.1. The EU27 trade with the UK at expected hard Brexit

The UK's withdrawal referendum from the EU took place in June 2016. Article 50 of the EU Treaty was activated in March 2017, and the Brexit date was initially set to 29 March 2019. As the agreement on conditions of the of UK withdrawal from the EU was not accepted, there was a threat of so-called hard Brexit, i.e. without an exit agreement. However, the Brexit date was postponed firstly to 12 April 2019, then to 31 October 2019 and finally to 31 January 2020. We can see a direct impact of this development on EU27 trade relations with the UK in Figure 2.

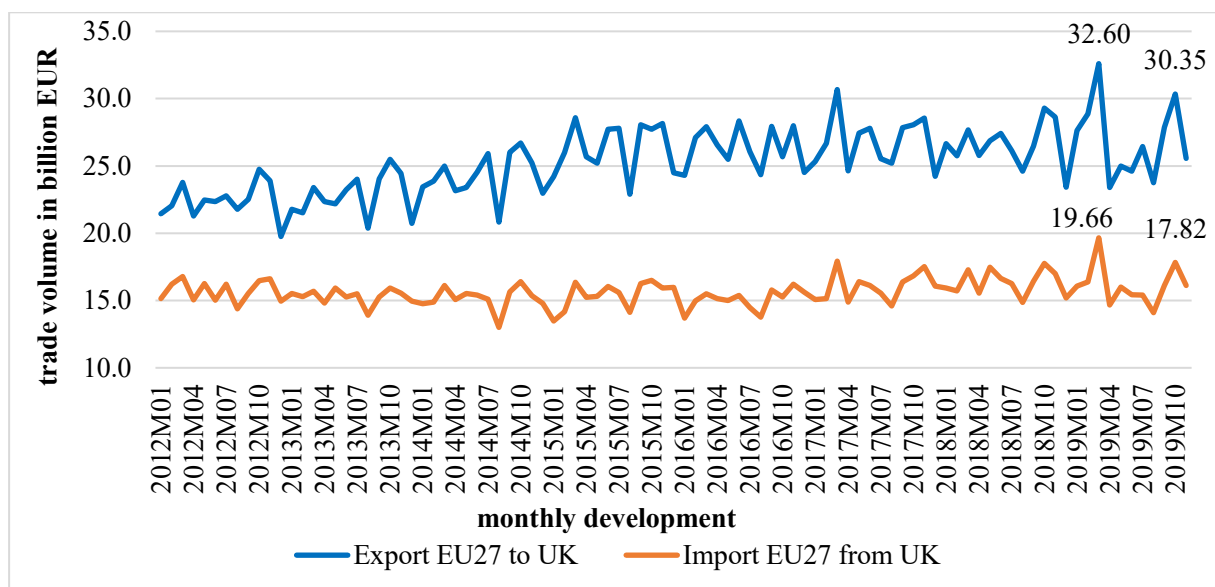

Figure 2: The EU27 trade development with the UK in 2012 – 2019 (in billion EUR)  
(Source: own calculation based on Eurostat 2019)

Figure 2 shows the monthly development of the EU27 and the UK trade between January 2012 and October 2019. Seasonality in the trade values development can be observed. The highest values of EU27 exports to the UK were reached always in March, June/July, September/October/ November in individual years. On the contrary, the lowest values were in April/May, August and December. Fears of hard Brexit in March 2019 caused that the increase in trade value was higher than in previous years. EU27 exports in March 2019 increased by 17.8% compared to March 2018. The year-to-year growth was lower, on average about 3%. Subsequently, in April 2019 EU27 exports to the UK fell by 28% compared to March 2019. Over the past seven years, the average percentage decline between April/March was 9%. In April 2019 compared to April 2018, exports fell by 9.24%.

As mentioned above, Brexit was postponed to 31 October 2019 and again there was a threat of hard Brexit. In October 2019, when compared to October 2018, EU27 exports to the UK grew by 3.6%. The average year-to-year growth since 2012 was 3%. Subsequently, in November 2019, compared to October 2019, there was a significant percentage decrease in EU27 exports to the UK by almost 16%. In the previous seven years, exports grew by 0.5% year-to-year. In November 2019, exports fell by almost 11% compared to November 2018.

We can also observe the seasonality of trade development in imports. The highest values were achieved in individual years in the months of March, May/June, September/October and November. The lowest values were in January/February, April, August and December. Uncontrolled Brexit threatened in March 2019, when we can see an increase in EU27 imports from the UK compared to March 2018 by almost 14%. The average year-to-year changes in imports since 2012 have been less than 1%. Subsequently, in April 2019, compared to March 2019, imports fell by over 25%. In the past seven years, the average percentage decline between April/March was 8.5%. In April 2019, imports fell by almost 6% compared to April 2018. The postponement of Brexit to 31 October 2019 caused just 0.3% increase in EU27 imports from the UK in October 2019 compared to October 2018. The average year-to-year growth since 2012 was 1.5%. In November 2019, when compared to October 2019, imports decreased by almost 10%. In the previous seven years, the average decline of imports was by only 0.8%. In November 2019, imports fell by more than 5% when compared to November 2018. Obtained data confirm that in the months of March and October 2019 (with hard Brexit threat) there was a stockpiling tendency among British households and firms aimed at minimizing negative impact of Brexit without agreement. The intention was to eliminate a risk of long queuing at border customs controls.

#### **4.2. EU intra-regional and extra-regional trade including UK**

Integration processes lead to interconnection of particular national economies or market segments. The EU is so far the best example of integration grouping in the world, proven by its level of intra-regional trade and high interdependence between the economies of the EU (i.e. trade between member states). The EU is also among the most open economies of the world and as a customs union it belongs to the most attractive regions to establish trade relations.

##### *4.2.1. EU intra-regional trade*

In this section, the EU intra-regional trade will be analyzed in terms of export and import, focusing on the UK's share of this trade and the changes in the context of Brexit. According to Eurostat data (2019), the total value of EU28 exports in 2018 amounted to 5,485 billion EUR, of which up to 3,527 billion EUR was formed by intra-regional exports. This implies that up to 64% of total EU exports (intra + extra-regional exports), in other words the most of the goods produced in EU Member States, remain in the EU. Figure 3 shows the value of intra-regional EU28 exports in 2012 – 2018 increasing from 2,838.7 billion EUR in 2012 to 3,526.9 billion EUR in 2018, representing an increase of more than 24%. The value of intra-regional exports of the UK increased from 185.0 billion EUR to 193.9 billion EUR, representing an increase of almost 5%. UK's share on total intra-regional EU28 exports 2012 – 2018 decreased by 1 percentage point from 6.5% to 5.5%.

Figure 4 shows intra-regional EU28 imports in 2012 – 2018 where the total changed from 2,771.1 billion EUR in 2012 to 3,453.6 billion EUR in 2018, representing an increase of almost 25%. The value of UK intra-regional imports changed from 257.7 billion EUR in 2012 to 301.3 billion EUR, reaching an increase of 17%. In percentage terms, however, the UK's share on intra-regional imports decreased by 0.6 percentage points over the whole examined period. The share was increasing until 2015 from 9.3% to 10.1%, but it fell down to 8.7% in 2018.

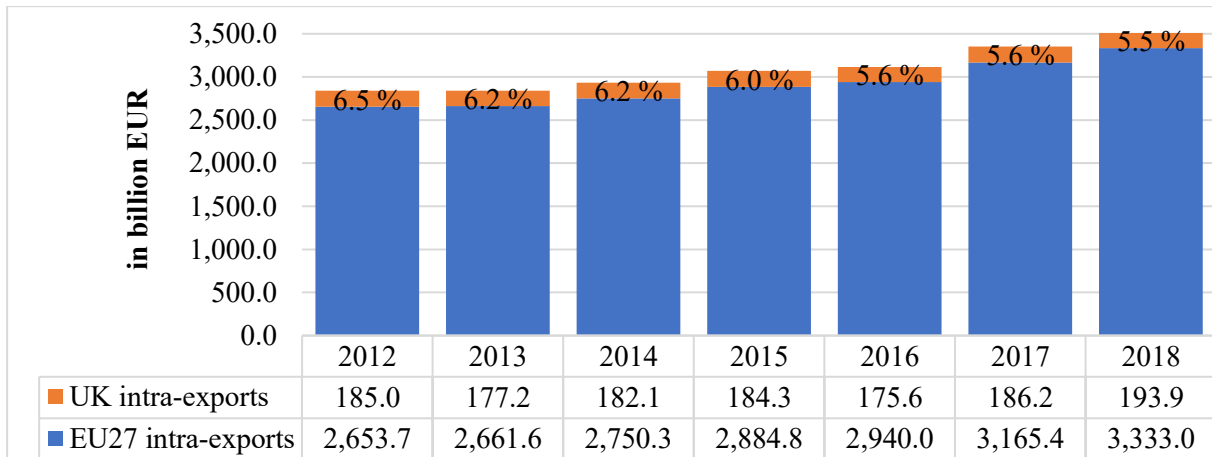

Figure 3: Intra-regional EU exports with UK's share in 2012 – 2018 (in billion EUR, in %) (Source: own calculation based on Eurostat 2019)

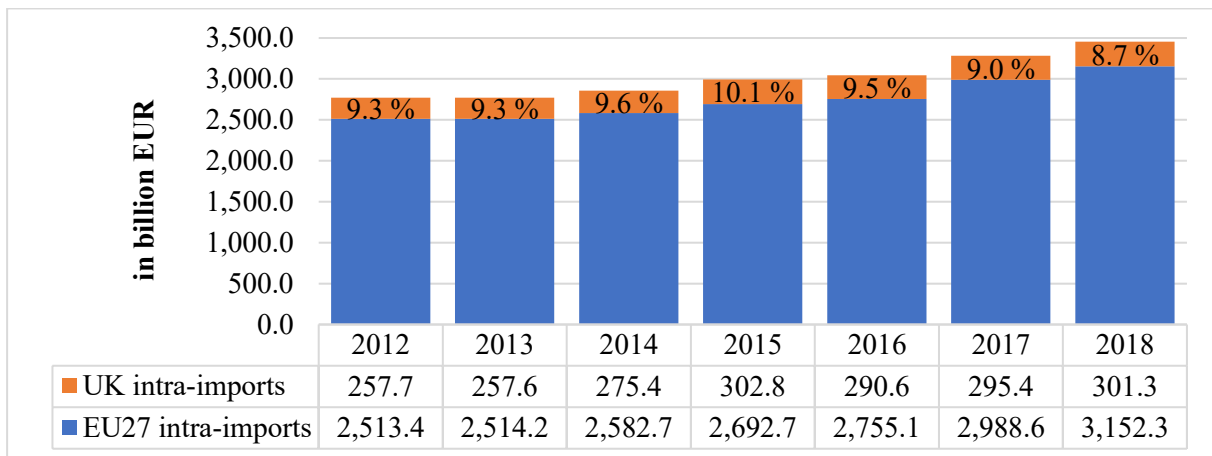

Figure 4: Intra-regional EU imports with UK share in 2012 – 2018 (in billion EUR, in %) (Source: own calculation based on Eurostat 2019)

As a result of the Brexit, the EU intra-regional trade has decreased. EU27 trade with the UK is no more be reported as intra-regional but as extra-regional (UK is a third country for EU members). Based on 2018 data, EU intra-regional trade after UK withdrawal has decreased by 14.4%, or 14.5%.

#### 4.2.2. EU extra-regional trade

In this section, extra-regional trade will be analyzed in terms of EU exports and imports, focusing on the UK's share of this trade and the changes in the context of Brexit. According to Eurostat data (2019), total exports of EU28 goods in 2018 amounted to 5,485 billion EUR, of which 1,957.8 billion EUR were extra-regional exports. This implies that 36% of total EU exports is generated by trading with third countries. Although only 6.9% of global population lives in the EU, trade with third countries accounts for around 15.6% of global exports and imports (Europa.eu, 2018). Figure 5 shows the value of EU28 extra-regional exports in 2012 – 2018 increasing from 1,684.9 billion EUR in 2012 to 1,957.8 billion EUR in 2018, representing 16% increase. The value of UK's extra-regional exports increased from 183.0 billion EUR to 218.1 billion EUR representing 19% increase. UK's share on the total extra-regional EU28 exports in 2012 – 2018 showed a marginal increase from 10.9% to 11.1%. UK's share of extra-regional exports has been volatile in recent years.

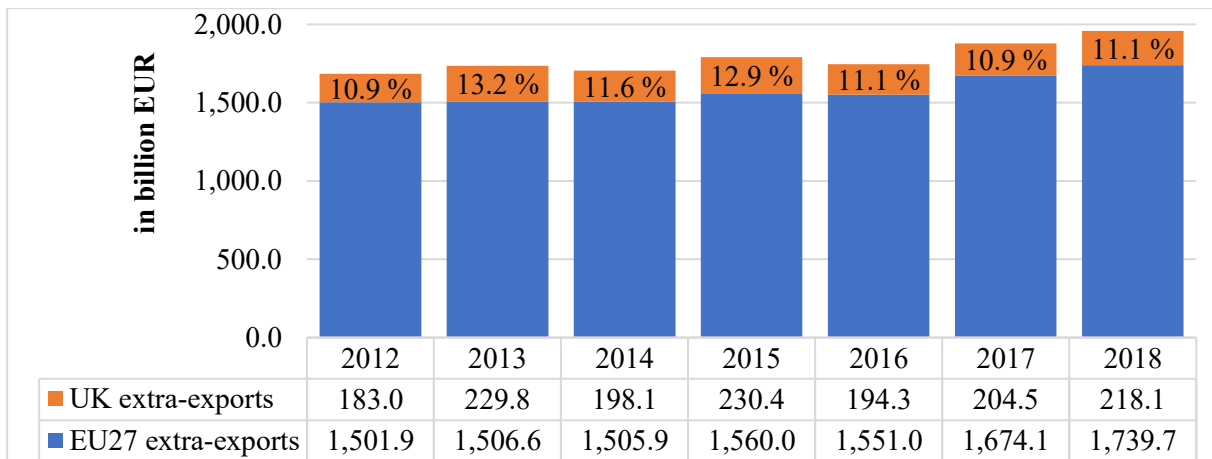

Figure 5: Extra-regional EU exports including UK in 2012 – 2018 (in billion EUR, in %)  
(Source: own calculation based on Eurostat 2019)

After the Brexit, the extra-regional EU27 exports have increased by 5.1% is (based on 2018 data). On one hand, UK's exports to third countries are no more part of the EU extra-regional export, on the other had EU27's exports to the UK are considered for extra-regional.

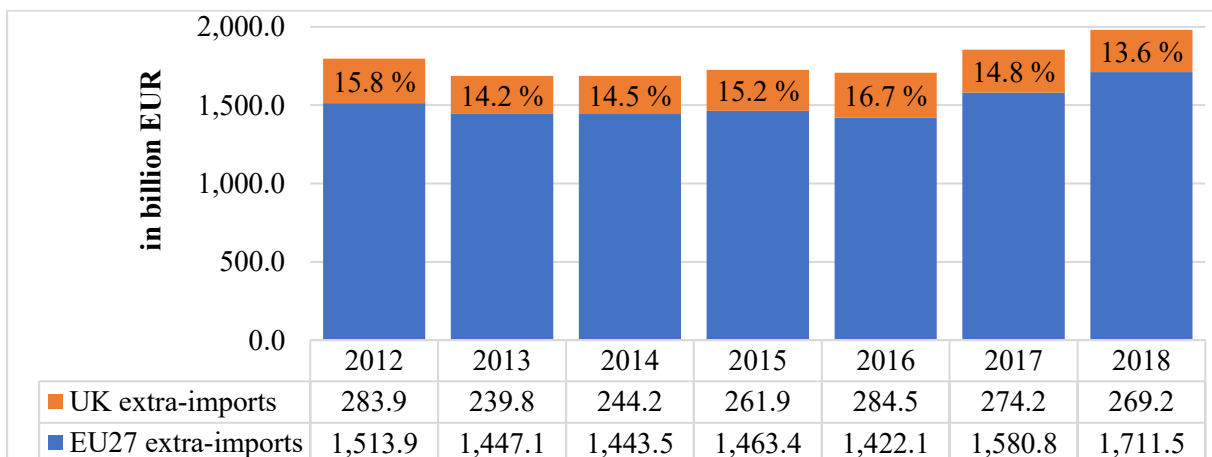

Figure 6: Extra-regional EU imports including UK in 2012 – 2018 (in billion EUR, in %)  
(Source: own calculation based on Eurostat 2019)

As seen in Figure 6, the extra-regional EU28 import in 2012 – 2018 increased from 1,797.7 billion EUR in 2012 to 1,980.8 billion EUR in 2018, representing a 10% increase. UK's extra-regional import changed from 283.9 billion EUR in 2012 to 269.2 billion EUR, indicating a decrease by 5%. In percentage terms, the UK's share of total extra-regional imports decreased too, namely by 2.2 percentage points. It was volatile during the examined period. Except for 2012, the UK's share of total extra-regional imports was increasing, but since 2016 it has declined from 16.7% to 13.6% in 2018. As a result of the UK's withdrawal from the EU, the EU extra-regional imports have increased by 3.7% (based on 2018 data). Even though extra-regional imports have been reduced by UK imports from third countries, EU27 imports from the UK have changed from intra-regional to extra-regional.

#### 4.3. Trade intensity and trade complementarity indexes

The TII trade intensity index was used to assess mutual trade between the EU27 and the UK. The Figure below gives an overview of the results of the surveyed index in 2012 – 2018.

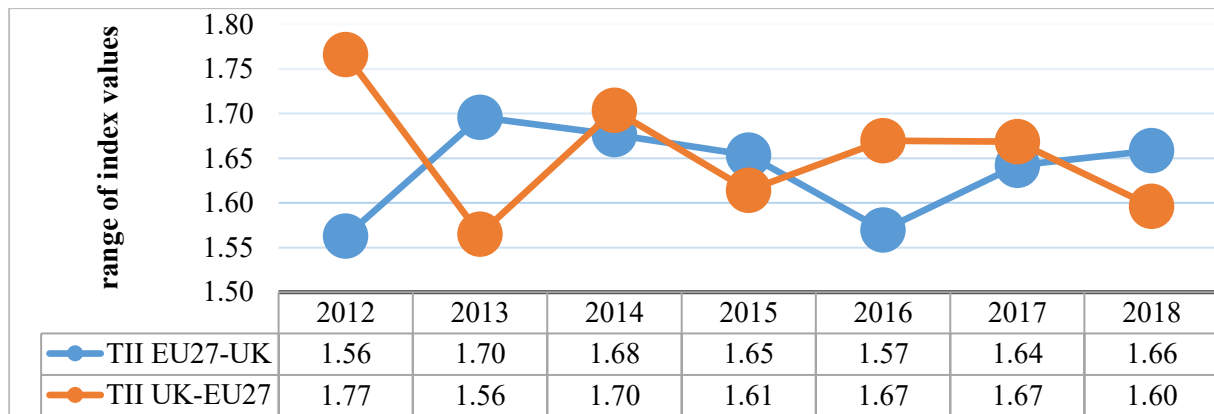

Figure 7: Development of trade intensity index of EU27 – UK and UK – EU27 trade in 2012 – 2018

(Source: own calculation based on ITC Trade Map 2019)

Figure 7 shows that the trade intensity between the EU27 and the UK in 2012 – 2018 was higher than 1. A value greater than 1 indicates a high intensity of foreign trade. The index values prove the existence of intense bilateral trade between the EU27 – UK. This follows from the UK's membership in the EU. In 2013, the value of the index increased by 0.14 points to 1.70 compared to 2012, which is the highest value in the reporting period. Since 2013, the index had a downward trend until 2016 reaching 1.57 points. Since 2017 it was increasing up to 1.66 points in 2018. Despite fluctuations, EU27 trade with the UK was continually intense as the index value did not fall below 1.0 in the examined period. The TII index UK – EU27 in 2012 – 2018 was also higher than 1, indicating intensive trade between the UK and the EU27. These values exceeded the EU27 – UK TII index several times, which means even more intensive trade on part of the UK. In 2013, when compared to the previous year, there was a decrease by 0.21 points from 1.77 to 1.56 points, being also the lowest value in the reporting period. In 2014, the index value increased again up to 1.70 points. In the following year, it fell again to 1.61 points. In 2016 – 2017, index value kept the same value of 1.67 points. In 2018, the value again decreased to 1.60 points. Despite the volatility of values, it can still be concluded that the UK trade with the EU27 was continually intense. The average of EU27 – UK TII for the reporting period reached 1.63 points. For TII UK – EU27, the index reached 1.65 points.

The Trade Complementarity Index also confirmed that the EU27 and the UK are highly interdependent trading partners. The result of the Complementarity Index can range from 0 (when countries are perfect competitors) to 100 (countries are ideal trading partners).

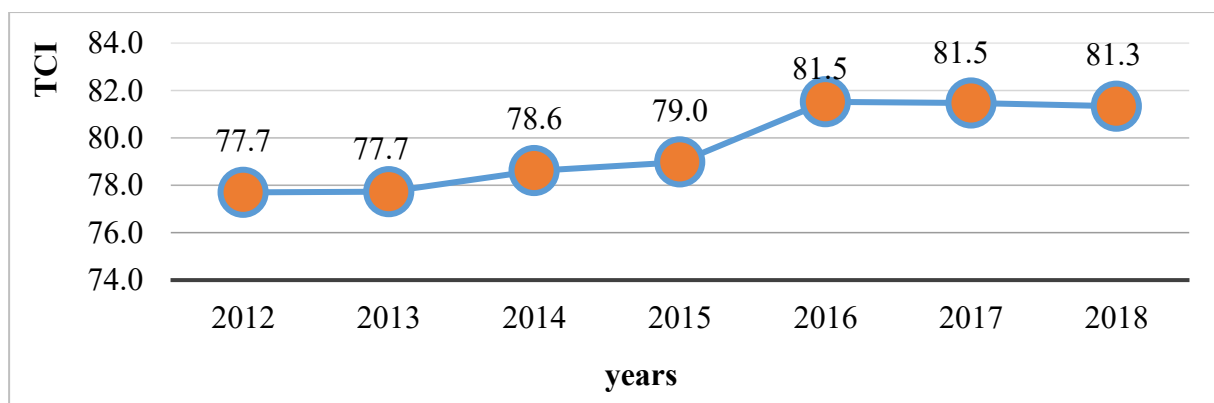

Figure 8: Trade Complementarity Index of EU27 – UK in 2012 – 2018

(Source: own calculation based on ITC Trade Map 2019)

Since 2012, the EU27 – UK complementarity index grew from 77.7 points to the maximum value of 81.5 in 2016 and 2017 (Figure 8). In 2018, there was a slight value decrease to 81.3. However, the index was increasing by 4.6% over the whole examined period. The high value like this suggests that both partners can profit from the trade. The development of the value of mutual trade also confirmed that. The values of trade intensity and trade complementarity indexes confirm that the EU27 and the UK were able to benefit from integration. It makes sense for both partners to maintain the preferential nature of trade relations after the Brexit. Applying trade barriers would disrupt natural trade flows and impact negatively both partners.

#### **4.4. UK's largest trading partners from the EU27**

The UK's withdrawal from the EU can destabilize those individual economies of the Union being the most involved in trade with the UK. According to data from ITC, the most goods were exported to the UK in 2018 from Germany in an amount of 82 billion EUR. It was followed by Netherlands reaching an export value of almost 40 billion EUR and France with 32.8 billion EUR. Other important EU27's exporters to the UK were Belgium (31.5 billion EUR) and Italy (23.1 billion EUR). When examining the share of the UK in the total EU27 exports into account, Ireland leads exports to the UK with the share of 11.4%, followed by Netherlands and Belgium with 8%, France and Spain with 6.8% (Table 1). By examining EU27 imports from the UK we found that the largest importers of UK goods according to import value in 2018 were Germany (36.8 billion EUR), Netherlands (26.3 billion EUR), France (20.6 billion EUR), Ireland (19.9 billion EUR) and Belgium (17.8 billion EUR). In terms of UK's share of total EU27 imports, Ireland had the highest share of UK imports, up to 21.9%. The next countries were Malta importing 8.3% of its total imports from the UK and Cyprus with 6.6%. Other EU27 countries with a high share of imports from the UK were the Netherlands with 6% and Sweden with 5%. According to KPMG (2017), the effect of Brexit on foreign trade will be most perceivable for Ireland, Luxembourg, Malta and Netherlands, given the high share of these countries on UK's exports in GDP.

## **5. CONCLUSION**

The aim of the paper was to assess changes in the EU trade relations within the context of Brexit (focusing on the EU27 – United Kingdom relations). The effect of Brexit expectations has materialized in the EU27's trade relations with the UK especially in the months of March and October 2019, when the EU27 exports to the UK increased on a year-to-year basis by 17.8%, resp. 4%. Similarly, there was a significant increase in EU27 imports from the UK in March 2019 in year-to-year comparison of almost 14%. This development was caused by expecting uncontrolled Brexit and the effort to eliminate the pending risk by stockpiling.

Immediately after Brexit, EU's intra-regional trade has declined. EU27 trade with the UK is not reported as intra-regional, but as extra-regional (UK has become a third country for EU members). Based on 2018 data, EU intra-regional has decreased by 14.4%, or 14.5% after UK's withdrawal. The EU extra-regional trade has increased after the UK's leaving. While UK trade with third countries is not anymore part of EU extra-regional trade, UK trade with EU27 has changed from intra-regional to extra-regional. Extra-regional exports have increased by 5.1% and extra-regional imports have increased by 3.7% (based on 2018 data).



The share of exports to the UK on total exports from the EU27 countries		The share of imports from the UK on total imports from the EU27 countries	
1. Ireland	11,4 %	1. Ireland	21,9 %
2. Netherlands	8,0 %	2. Malta	8,3 %
3. Belgium	8,0 %	3. Cypress	6,6 %
4. France	6,8 %	4. Netherlands	6,0 %
5. Spain	6,8 %	5. Sweden	5,0 %
6. Portugal	6,4 %	6. Belgium	4,7 %
7. Germany	6,2 %	7. France	3,7 %
8. Denmark	6,2 %	8. Denmark	3,6 %
9. Latvia	5,6 %	9. Spain	3,6 %
10. Sweden	5,5 %	10. Germany	3,4 %

Table 1: EU27 countries by share of exports to/imports from the UK on their total exports/imports (in %)

(Source: own calculation based on ITC Trade Map 2019)

Regarding the changes in the EU27 trade relations with the UK after Brexit in the long term, they will be determined by the trade agreement negotiated between the EU and the UK. According to our findings the EU27 and the UK were able to increase their trade intensity and trade complementarity to a high level therefore it is mutually beneficial for them to maintain the preferential nature of trade relations even after Brexit. Applying the trade barriers would disrupt natural trade flows and impact negatively both partners. The biggest losses would be recorded with the largest trading partners of the UK. From the perspective of individual EU countries and based on the share of exports to the UK in total exports, these are Ireland, Netherlands and Belgium. Based on the share of imports in total imports, these are Ireland, Malta and Cyprus.

**ACKNOWLEDGEMENT:** This paper is a part of a research project of the Ministry of Education, Family and Sports of the Slovak Republic VEGA (in the period 2020 - 2022) No. 1/0777/20: Belt and Road initiative - opportunity or threat for the EU and Slovak export competitiveness?

#### LITERATURE:

1. Bertelsmann Stiftung. (2019). *Estimating the impact of Brexit on European countries and regions*. Policy Paper. Retrieved 20.01.2020 from [https://www.bertelsmann-stiftung.de/fileadmin/files/user\\_upload/EZ\\_Estimating\\_the\\_Impact\\_of\\_Brexit\\_2019\\_EN\\_G.pdf](https://www.bertelsmann-stiftung.de/fileadmin/files/user_upload/EZ_Estimating_the_Impact_of_Brexit_2019_EN_G.pdf).
2. Cierco, T. (2013). *European Union Neighbourhood: Challenges and opportunities*. London: Routledge.
3. De Ville, F. – Siles-Brugge, G. (2019). The Impact of Brexit on EU Trade Policy. *Politics and governance*, 7(3), 7–18.
4. Drieniková, K. (2016). Hospodárska spolupráca EÚ s regiónom Strednej Ázie. *Nové výzvy v oblasti európskej energetickej bezpečnosti a ich vplyv na konkurencieschopnosť EÚ v horizonte do roku 2020* (Research report no. 1/0550/14). Bratislava : Vydavateľstvo EKONÓM.
5. Econpol Europe. (2017). *Economic effects of Brexit on the European economy*. Policy report. Retrieved 20.01.2020 from [https://www.ifo.de/DocDL/EconPol\\_Policy\\_Report\\_04\\_2017\\_Brexit.pdf](https://www.ifo.de/DocDL/EconPol_Policy_Report_04_2017_Brexit.pdf).

6. Europa.eu. (2018). *Základné informácie o Európskej únii. Hospodárstvo*. Retrieved 16.12.2019 from [https://europa.eu/european-union/about-eu/figures/economy\\_sk](https://europa.eu/european-union/about-eu/figures/economy_sk).
7. European Committee of the Regions. (2018). *Assessing the impact of the UK's withdrawal from the EU on regions and cities in EU27*. Commission for Economic Policy. Retrieved 20.01.2020 from <https://op.europa.eu/en/publication-detail/-/publication/38798c7b-387c-11e8-b5fe-01aa75ed71a1>.
8. Eurostat. (2019). *Statistics A – Z*. Retrieved 20.12.2019 from <https://ec.europa.eu/eurostat/data/statistics-a-z/stuv>.
9. HM Government. (2018). *EU Exit. Long-term economic analysis*. Retrieved 16.12.2019 from [https://assets.publishing.service.gov.uk/government/uploads/system/uploads/attachment\\_data/file/76084/28\\_November\\_EU\\_Exit\\_-\\_Long-term\\_economic\\_analysis\\_1.pdf](https://assets.publishing.service.gov.uk/government/uploads/system/uploads/attachment_data/file/76084/28_November_EU_Exit_-_Long-term_economic_analysis_1.pdf).
10. Kaš'áková, E. et al. (2019). *Impact of the Geopolitical Changes on the EU Foreign Trade Relations with Selected territories : Implications for the Slovak Economy*. Saint Petersburg : Saint Petersburg University Press.
11. Kittová, Z. (2020). The European Union as a Major Trading Player in the Global Economy. In Bayar Y. (ed.), *Handbook of Research on Social and Economic Development in the European Union* (p. 45–68). USA : IGI Global.
12. KPMG economics insights. (2017). *Brexit: The view from Europe*. Retrieved 14.01.2020 from <https://home.kpmg/content/dam/kpmg/sk/pdf/2017/brexit-the-view-from-europe.pdf>.
13. Make UK. (2019). *Preparing for Brexit. Guidance for the steel sector*. Retrieved 16.12.2020 from <https://www.makeuk.org/-/media/UK-Steel---Preparing-for-Brexit---Guidance-for-the-steel-sector---Update-1.pdf>.
14. RAND Corporation. (2017). *After Brexit: Alternate forms of Brexit and their implications for the United Kingdom, the European Union and the United States*. Retrieved 16.12.2020 from [https://www.rand.org/pubs/research\\_reports/RR2200.html](https://www.rand.org/pubs/research_reports/RR2200.html).
15. Ružeková, V. – Krivosudská, S. (2019). Evaluation of the Impact of the Free Trade Agreement between the EU and the Republic of Korea and Its Impact on Foreign Trade of the Slovak Republic. *Trends and Challenges in the European Business Environment: Trade, International Business and Tourism*. Bratislava : Vydavateľstvo EKONÓM, pp. 393–402.
16. Smith, M. (2019). The European Union and the Global Arena: In Search of Post-Brexit Roles. *Politics and Governance*, 7(3), 83-92.
17. The New York Times. (2016). *Text of David Cameron's speech after Brexit vote*. Retrieved 18.12.2019 from <https://www.nytimes.com/2016/06/25/world/europe/david-cameron-speech-transcript.html>
18. Trade map. (2019). *Trade statistics for international business development*. Retrieved 18.12.2019 from <https://www.trademap.org/>.
19. World Bank. (2010). *Trade Indicators*. Retrieved 08.12.2019 from [http://wits.worldbank.org/wits/wits/witshelp/Content/Utilities/e1.trade\\_indicators.htm](http://wits.worldbank.org/wits/wits/witshelp/Content/Utilities/e1.trade_indicators.htm).
20. World Bank. (2013). *Online Trade Outcomes Indicators*. Retrieved 08.12.2019 from <http://wits.worldbank.org/WITS/docs/TradeOutcomes-UserManual.pdf>.
21. World Trade Organization. (2019). *World trade statistical review 2019*. Retrieved 18.12.2019 from : [http://www.wto.org/english/res\\_e/statis\\_e/wts2019\\_e/wts2019\\_e.pdf](http://www.wto.org/english/res_e/statis_e/wts2019_e/wts2019_e.pdf).

# COMPARISON OF CHOSEN FINANCIAL DISTRESS PREDICTION MODELS FOR NON-PROFIT ORGANIZATIONS

**Filip Rebetak**

*University of Žilina, Univerzitná 8215/1, Žilina, Slovakia  
filip.rebetak@fpedas.uniza.sk*

## **ABSTRACT**

*Non-profit organizations are an important part of society and economy by providing solutions and services where needs are not met by private sector or government. Its importance is only growing. It is important to know how to assess their financial wellbeing, their financial health. In non-profit organizations, the term financial vulnerability is used to name an organization's susceptibility to financial problems. In this article, we focus on presenting some of the models for prediction of financial vulnerability in non-profit organizations that were developed in later years and have been used extensively since in scientific literature. Aim is to provide overview of models to enable further research in this area to deal with possible limitations such as country and sector specificity of financial distress modelling.*

**Keywords:** *non-profit organization, financial vulnerability, prediction of financial vulnerability*

## **1. INTRODUCTION**

Non-profit organizations represent an important part of society and economy by providing solutions and services where needs are not met by private sector or government. Its importance is only growing. It is important to know how to assess their financial wellbeing, their financial health. In non-profit organizations, the term financial vulnerability is used to name an organization's susceptibility to financial problems. The exact definitions and boundaries for deciding which non-profit organization is financially vulnerable varies between the authors and will be mentioned later in the article. In contrast to the for-profit business, non-profit organizations are working for public good without intention of making profit for their founders. Nevertheless, they might also want to assess whether their organization is in state of financial distress and thus is vulnerable to financial shocks. Managers and board members of non-profit organizations might use them to better guide their decision. Their creditors or donors might want to analyze their financial vulnerability before offering a loan or donating money. The same might be true for government while deciding to distribute grants among many non-profits or while formulating public policy. In case of for-profit business, there are many financial distress prediction models available for use such as ones of the most used old models dating back to 1960s - Altman (1968) and Ohlson (1980) models. (Gordon et al., 2013)

Altman (1968) used multivariate discriminant analysis. Ohlson (1980) was the first to use logistic regression. (Durica, Podhorska, Durana, 2019). Newer models use many different methods for formulation of models. Discriminant analysis is still used for prediction of bankruptcy. (Kliestik et al., 2018; Yakymova, Kuz, 2019; Karas, Srbova, 2019). Other authors use decision tree methods, such as the CART-based model by Durica, Podhorska, Durana (2019). Lately, there has been an emergence of use of neural network models (Suler, 2017; Vrbka, Nica, Podhorska, 2019) to predict financial distress. Some authors focus on the risk factors and variables used in models to find the best predictors. (Valaskova, Kliestik, Kovacova, 2018; Kovacova et al., 2019; Belas et al., 2019). Bin et al. (2019) deals with management of working capital. We can see that financial distress prediction has been extensively studied for the for-profit sector. However, financial vulnerability of nonprofit organizations has been ignored by the academic literature until the '90s. (Andres-Alonso et al., 2015) First foray into this area was in 1991, by Tuckman and Chang who identified four accounting ratios to indicate

financial vulnerability. (Tevel, Brock, Kaz, 2014) In this article, we focus on presenting some of the models for prediction of financial vulnerability in non-profit organizations that were developed in later years. Aim is to provide overview of models to enable further research in this area to deal with possible limitations such as country and sector specificity of financial distress modelling.

## 2. METHODOLOGY

In the following chapter, we will present a few chosen financial prediction models for non-profit organization. We chose these models, after researching through Web of Science and Google Scholar databases for prediction models for non-profit organizations focused on predicting their financial distress, financial vulnerability, or financial health. We focused on collecting them along with their formulas for calculation and variables in order to compare them later in the article. This article is also aimed to be a summary available for researchers to use while working on non-profit financial vulnerability prediction.

## 3. CHOSEN FINANCIAL PREDICTION MODELS FOR NON-PROFIT ORGANIZATIONS

We chose Tuckman and Chang (1991) model, Greenlee and Trussel (2000) model, Trussel (2002), Trussel et al. (2002), Greenlee and Trussel (2004) and Ohlson (1980) models.

All these models were used in many journal articles and are constituting a core of knowledge in the area of non-profit financial distress prediction.

### 3.1. Tuckman and Chang (1991)

Model developed for assessing of financial vulnerability of non-profit organizations by Tuckman and Chang (1991) was one of the first ones. It is also the most used model for predicting non-profit financial vulnerability in non-profit management literature. (Tevel, Brock, Kaz, 2014). They used random sample of 4730 non-profit organizations from United States in their research- They posited that a nonprofit was financially vulnerable if it were “likely to cut back its service offerings immediately when it experiences a financial shock.” To assess whether or not a non profit organization is financially vulnerable Tuckman and Chang (1991) model used 4 accounting ratios as variables that could show the financial vulnerability: equity ratio, concentration of revenues, administrative costs and operating margin. (Keating et al., 2005)

These variables are defined as follows: (Tuckman, Chang, 1991)

Equity ratio = Net Assets / Total Revenues

Concentration of revenues = through a revenue concentration index

$$RCI = \sum \left( \frac{Revenue_i}{Total Revenue} \right)^2$$

where Revenue<sub>i</sub> is revenue from the source of revenue i for the non-profit organization

Administrative costs ratio = Administrative Expenses / Total Revenues

Operating margin = Net Income / Total Revenues

The formula for deciding the financial vulnerability of non-profit organizations through this model by Tuckman and Chang (1991) was to calculate all the variables and if any of those values are in the last quintile (i.e. any of the ratios is below 0,2) then the organization is financially vulnerable.

### 3.2. Greenlee and Trussel models (2000 & 2004)

#### 3.2.1. Greenlee and Trussel (2000)

Greenlee and Trussel model (2000) expanded on the Tuckman and Chang (1991) model to develop a model for prediction of financial distress of non-profit organizations. They used multiyear data for IRS database concerning 3,151 US non-profit organizations and applied logistic regression to find a suitable prediction model. The model is based on the same financial indicators as Tuckman and Chang (1991), so the variables for Greenlee and Trussel (2000) are:

Equity ratio = Net Assets / Total Revenues

Concentration of revenues = through a revenue concentration index

$$RCI = \sum \left( \frac{Revenue_i}{Total Revenue} \right)^2$$

where Revenue<sub>i</sub> is revenue from the source of revenue i for the non-profit organization

Administrative costs ratio = Administrative Expenses / Total Revenues

Operating margin = Net Income / Total Revenues

Their improvement over the Tuckman and Chang (1991) model is the logit function which gives the probability of financial distress for a given non-profit organization. The model is as follows:

$$\text{Probability of financial vulnerability } FV = \frac{1}{(1+e^{-Z})}$$

$$Z = -3,0610 + 0,1153 \times \text{Equity ratio} + 1,2528 \times \text{Revenue Concentration Index} \\ - 2,2639 \times \text{Administrative costs} - 3,4289 \times \text{Operating Margin}$$

The interpretation of the results is that for  $FV \leq 7\%$  is a strong indicator of financial invulnerability. Results between 7 and 10 % are in the gray zone and  $FV$  over 10% is a strong indicator of financial vulnerability. (Cordery, Baskerville, 2010)

#### 3.2.2. Trussel and Greenlee (2004)

Greenlee and Trussel collaborated on another model which they presented in 2004 in their paper *A financial rating system for charitable nonprofit organizations*. They defined financial distress as a significant decrease in net assets over a three-year period. This is once more a model made using logistic regression and once more it used some of the variables as Tuckman and Chang (1991) model: revenue concentration index, administrative costs ratio and operating margin (or surplus margin). They eliminated administrative cost ratio and changed equity ratio to debt ratio. Furthermore, they added two control variables for size of the non-profit organization and the sector in which it operates. The model is as follows: (Cordery, Sim, Baskerville, 2013)

$$Z = 1.4398 - 5,2450 \times \text{Operating margin} + 0.0764 \times \text{Revenue concentration index} - 0.1594 \times \text{Size} + 0.9754 \times \text{Debt ratio}$$

$$\text{Probability of financial vulnerability } FV = \frac{1}{(1+e^{-Z})}$$

With variables calculated followingly:

$$\text{Operating margin} = \text{Net Income} / \text{Total Revenues}$$

Concentration of revenues = through a revenue concentration index

$$RCI = \sum \left( \frac{\text{Revenue}_i}{\text{Total Revenue}} \right)^2$$

where Revenue<sub>i</sub> is revenue from the source of revenue i for the non-profit organization

$$\text{Debt ratio} = \text{Total debts} / \text{Total Assets}$$

$$\text{Size} = \text{natural log of total assets}$$

### 3.3. Trussel (2002)

Trussel (2002) model was made using dataset of approximately 94 000 US based non-profit organisations. He expanded on previous models Greenlee and Trussel (2000) by using slightly different financial indicators, controlling for more sectors, and using a larger database. He defined organization as financially vulnerable if it had more than a 20 percent decrease in its fund balance over a three-year period. He used following variables to develop financial profiles: the debt ratio, the revenue concentration index, the surplus margin (the excess of revenues over expenses) plus the size of the organization and the sector to which the organization belongs.

$$\text{Debt ratio} = \text{Total liabilities} / \text{total assets}$$

$$\text{Revenue concentration index} = \sum \left( \frac{\text{Revenue}_i}{\text{Total Revenue}} \right)^2$$

$$\text{Surplus margin} = (\text{Total Revenues} - \text{Total Expenses}) / \text{Total Revenues}$$

$$\text{Size} = \text{natural log of total assets}$$

Sector = used the sectors according to US National Taxonomy of Exempt Entities, being a dummy variable.

The full model is as follows:

$$Z = 0,2475 + 1,1088 \times \text{Debt Ratio} + 0,8402 \times \text{Revenue concentration index} - 1,3527 \times \text{Surplus margin} - 0,1396 \times \text{Size} + \text{Sector}$$

$$\text{Probability of financial vulnerability } FV = \frac{1}{(1+e^{-Z})}$$

The decision value is 0,2.

### 3.4. Trussel et al. (2002)

Trussel et al. (2002) is another model by John Trussel in collaboration with Janet Greenlee, this time also with Thomas Brady. It uses more similar variables than previous models like Trussel (2002), Greenlee and Trussel (2000) and Tuckman and Chang (1991). Published in a CPA journal (Certified Public Accountant), it was meant as a guide for auditors when trying to evaluate the financial condition of a tax-exempt organization. They created the Financial Vulnerability Index. Its formula is as follows:

$$\text{Financial vulnerability index } FVI = \frac{1}{(1+e^{-Z})}$$

where

$$Z = 0.7754 + 0.9272 \times \text{Debt ratio} + 0.1496 \times \text{Revenue concentration index} - 2.8419 \times \text{Surplus margin} + 0.1206 \times \text{Administrative costs ratio} - 0.1665 \times \text{Size}$$

Variables for this model are:

$$\text{Debt ratio} = \text{Total liabilities} / \text{total assets}$$

$$\text{Revenue concentration index} = \sum \left( \frac{\text{Revenue}_i}{\text{Total Revenue}} \right)^2$$

$$\text{Surplus margin} = (\text{Total Revenues} - \text{Total Expenses}) / \text{Total Revenues}$$

$$\text{Administrative costs ratio} = \text{Administrative Expenses} / \text{Total Revenues}$$

$$\text{Size} = \text{natural log of total assets}$$

The decision rules are:  $FVI > 0,20$  means the organization is financially vulnerable,  $FVI < 0,10$  means the organization is not financially vulnerable. The range  $0,10-0,20$  is inconclusive. (Trussel et al., 2002; Andres-Alonso et al., 2015)

### 3.5. Ohlson (1980)

Ohlson (1980) model was developed originally for the business sector. However, it is also used in research for prediction of financial distress of non-profit organizations. (Keating et al., 2005). The Ohlson model is using six variables to calculate the O-score:

$$X1 = \log (\text{Total Assets} / \text{Gross National Product Price Index level})$$

$$X2 = \text{Total Liabilities} / \text{Total Assets}$$

$$X3 = \text{Working Capital} / \text{Total Assets}$$

$$X4 = \text{Short-term liabilities} / \text{Short-term assets}$$

$$X5 = 1, \text{ if Total Liabilities bigger than Total Assets, otherwise } 0$$

$$X6 = \text{Net Income} / \text{Total Assets}$$

$$X7 = \text{Cash} / \text{Total Liabilities}$$

$X_8 = 1$ , if Net Income was negative for the last two years, 0 otherwise

$X_9$  = the scaled change in Net Income from last year.

The O-score is calculated as follows:

$$\text{O-score} = -1,32 - 0,407X_1 + 6,03X_2 - 1,43X_3 + 0,0757X_4 - 1,72X_5 - 2,37X_6 + 1,83X_7 + 0,285X_8 - 0,521X_9$$

Then the probability of default is computed as:

$$p = \frac{e^{O\text{-score}}}{1 + e^{O\text{-score}}}$$

#### 4. RESULTS - COMPARISON OF THE CHOSEN MODELS

The previous chapter provided an overview of a few most used model in financial distress prediction. In this chapter, we will focus on the comparison of these models. First of all, we have to mention the importance of Tuckman and Chang (1991) model which is to this date one of the most used models in this area. (Tevel, Katz, Brock, 2015). Not only it is still used in research papers, its choice of variables influenced many of the later developed models, as we can see all or some of its variables in 3 out of 4 other models and these variables are still used by Gordon, Fischer, Greenlee and Keating in 2013 or Tevel, Brock, Katz in 2015. We can also see that addition of size and sector of non-profit in Trussel (2002) and Trussell and Greenlee (2004). Cordery, Baskerville (2010) find that addition of the variable of Size, provides better results. These models were also all developed in US, on the data from US organizations. This might prove limiting for their use in other countries. (Andres-Alonso et al., 2015) However, there are also examples of successful use of these US developed models abroad. (Tevel, Katz, Brock, 2015). Andres-Alonso et al. (2015) used model by Trussel et al.(2002) on non-governmental development organizations in United Kingdom and found it to be poorly adapted to that particular industry. However, they identified some problems, such their sample was small (228) and only from a particular sector, while also using different kind of data due to the difference in tax systems between UK and US where Trussel et al. (2002) was developed. Tevel, Brock and Katz (2015) tested many models, among them Tuckman and Chang (1991) model, finding it the best for identifying financial vulnerability in non-profit organizations. Gordon, Fischer, Greenlee and Keating (2013) note that all existing prediction models are not totally effective in predicting which particular organizations will experience distress in the coming year and suggest using the results of these models as providing a likelihood of insolvency rather than a certainty. Ohlson model is the only model in this article originally made for for-profit organizations. Its variables are not all compatible with use in non-profit context and need adjusting. (Gordon et al., 2013) Keating, Fischer, Gordon and Greenlee (2005) find that Ohlson has higher explanatory power than Tuckam and Chang (1991) or Altman (1968). On the other hand, Tevel, Katz, Brock (2014) state that Ohlson's model came out insignificant, and it probably is not suitable for the analysis of nonprofit organizations.

#### 5. CONCLUSION

In this article, we focused on the most used models in research for prediction of financial vulnerability or distress of non-profit organizations. We compared 6 models that have been widely used in scientific literature. These models might be useful for a range of possible users. Managers and board members of non-profit organizations can use them to keep an eye on the financial health of their organizations. Government, its departments and agencies might use



them while deciding to award contracts, redistributing grants or setting policy and rules for the non-profit sector. Creditors might want to use these models to assess creditworthiness of non-profit organizations as potential debtors. And finally, the volunteers or donor might want to use these to assess the financial health of an organization they are contributing to. However, the practical use of these models might be limited, as some authors suggest (Andres-Alonso et al., 2015; Gordon et al., 2013) and it is advisable to use them with discretion and base decision also on other data. The limitations might be numerous. Among them is the country factor. All of the models were constructed on the basis of data from US databases, mostly from the tax collector – Internal Revenue Service (IRS). Thus, these models might not be useful in some countries because of the differences in the functioning of the non-profit sector. Another difference might be due to the different tax laws regarding non-profit which might create differences in the structure and content of the data upon which are based the calculations. Another limitation might be the sectoral differences between sectors of non-profit organizations. Some models (Trussel, 2002) are trying to address this by including sector variable. All of these limitations might be possible areas for further research – such as creation of country specific or sector specific models.

**ACKNOWLEDGEMENT:** *This paper is an outcome of project VEGA: 1/0544/19 Formation of the methodological platform to measure and assess the effectiveness and financial status of non-profit organizations in the Slovak Republic.*

#### LITERATURE:

1. Altman, E. (1968). Ratios, discriminant analysis, and the prediction of corporate bankruptcy. *Journal of Finance*.
2. Andres-Alonso, P., Garcia-Rodriguez, I., Romero-Merino, M. (2015). The Dangers of Assessing the Financial Vulnerability of Nonprofits Using Traditional Measures. *Nonprofit Management and Leadership*, 25(4), 371-382.
3. Belas, J., Smrcka, L., Gavurova, B., Dvorsky, J. (2018). The Impact of Social and Economic Factors in the Credit Risk Management of SME. *Technological and Economic Development of Economy*, 24(3), 1215–1230.
4. Bin, L., Chen, J., Tran, D. S. (2019). Exploring the Determinants of Working Capital Management: Evidence across East Asian Emerging Markets. *Economics, Management, and Financial Markets*, 14(2), 11–45.
5. Cordery, C. J., Sim, D., Baskerville, R. F. (2013). Three models, one goal: Assessing financial vulnerability in New Zealand amateur sports clubs. *Sport Management Review*, 16(2), 186-199.
6. Cordery, C., Baskerville, R. (2010). *Assessing financial vulnerability in nonprofit organisations*. Retrieved 22.04.2020 from <https://ssrn.com/abstract=1634473>
7. Durica, M., Podhorska, I., Durana, P. (2019). Business failure prediction using cart-based model: A case of Slovak companies. *Ekonomicko-manazerske spektrum*, 13(1), 51-61.
8. Gordon, T.P., Fischer, M., Greenlee, J., Keating, E.. (2013). Warning Signs: Nonprofit Insolvency Indicators. *International Research Journal of Applied Finance*.
9. Greenlee, J. S., Trussel, J. M. (2000). Predicting the Financial Vulnerability of Charitable Organizations. *Nonprofit Management & Leadership*, 11(2), 199-210.
10. Karas, M., Srbova, P. (2019). Predicting bankruptcy in construction business: Traditional model validation and formulation of a new model. *Journal of International Studies*, 12 (1).
11. Keating, E. K., Fischer, M., Gordon, T. P., Greenlee, J. S. (2005). Assessing Financial Vulnerability in the Nonprofit Sector. *KSG Working Paper*, 27.

12. Kliestik, T., Misankova, M., Valaskova, K., Svabova, L. (2018). Bankruptcy prevention: new effort to reflect on legal and social changes. *Science and Engineering Ethics*, 24(2), 791-803.
13. Kovacova, M., Kliestik, T., Valaskova, K., Durana, P., Juhaszova, Z. (2019). Systematic review of variables applied in bankruptcy prediction models of Visegrad group countries. *Oeconomia Copernicana*, 10(4), 743-772.
14. Ohlson, J. (1980). Financial ratios and the probabilistic prediction of bankruptcy. *Journal of Accounting Research*.
15. Suler, P. (2017). Using Kohonen's neural networks to identify the bankruptcy of enterprises: Case study based on construction companies in South Bohemian region. *Proceedings of the 5th International Conference Innovation Management, Entrepreneurship and Sustainability*, Prague, Czech Republic, 985-995.
16. Tevel, E., Katz, H., Brock, D. M. (2015). Nonprofit Financial Vulnerability: Testing Competing Models, Recommended Improvements, and Implications. *International Journal of Voluntary and Nonprofit Organizations*, 26(6), 2500-2516.
17. Tevel, E., Katz, H., Brock, D. M. (2015). Nonprofit Financial Vulnerability: Testing Competing Models, Recommended Improvements, and Implications. *International Journal of Voluntary and Nonprofit Organizations*, 26(6), 2500-2516.
18. Trussel, J. M. (2002). Revisiting the Prediction of Financial Vulnerability. *Nonprofit Management & Leadership*, 13(1), 17-31.
19. Trussel, J., Greenlee, J., (2004). A financial rating system for nonprofit organizations. *Research in Government and Nonprofit Accounting*, 11, 105-128.
20. Trussel, J., Greenlee, J., Brady, T. (2002). Predicting financial vulnerability in charitable organizations: Certified public accountant. *The CPA Journal*, 72(6), 66-69. Retrieved 20.04.2020 from <https://search.proquest.com/docview/212290344?accountid=49401>
21. Tuckman, H. P., Chang, C. F. (1991). A Methodology for Measuring the Financial Vulnerability of Charitable Nonprofit Organizations. *Nonprofit and Voluntary Sector Quarterly*, 20(4), 445-460.
22. Valaskova, K., Kliestik, T., Kovacova, M. (2018). Management of financial risks in Slovak enterprises using regression analysis. *Oeconomia Copernicana*, 9(1), 105–121.
23. Vrbka, J., Nica, E., Podhorská, I. (2019). The application of Kohonen networks for identification of leaders in the trade sector in Czechia. *Equilibrium. Quarterly Journal of Economics and Economic Policy*, 14(4), 739-761.
24. Yakymova, L., Kuz, V. (2019). The use of discriminant analysis in the assessment of municipal company's financial health. *Economics and Sociology*, 12 (2).

# THE DIGITAL TRANSFORMATION OF TRADITIONAL FASHION RETAIL FOR SUSTAINABLE GROWTH

**Sandra Raquel Alves**

*CIC.DIGITAL; ESTG, Polytechnic Institute of Leiria, Portugal  
raquel.alves@ipleiria.pt*

**Humberto Ribeiro**

*GOVCOPP; ESTGA, University of Aveiro, Portugal  
hnr@ua.pt*

**Raja Saravanan**

*University of Aveiro, Portugal  
vijaysk01995@gmail.com*

## ABSTRACT

*This paper examines how traditional fashion retailers in India are adapting to the new digital environment. During the current COVID-19 pandemic time, traditional companies struggle to operate and survive. This main objective of this research is to suggest a strategic solution for the future of businesses. India's growing international competitiveness within the fashion industry sector is due to its full supply chain. The fashion industry retailer should adopt an Omni-channel approach. The reason is that consumers are increasingly purchasing goods using multiple retail channels, increasing the number of average customer sales and the Omni-channel customer value of the number of channels accepted. Despite the Indian nation difficulties to overcome the difficulties during this crisis, this COVID-19 condition suggests that every traditional business model should take this opportunity to move into the digital arena. We found some prevailing drawback in India from our survey. We used null hypothesis to test our data independence through cross-tabulation analysis by using Chi-squared. We suggest that retailer should utilize this big opportunity to thrive in the fashion Industry and to ease the customer shopping experience.*

**Keywords:** *Fashion Retail, Traditional Retail, Digital transformation, Omni-channel, Image Interactivity Technology, 3D-Body scanning, Magic mirror technology*

## 1. INTRODUCTION

Today's retail environment is more competitive than ever. From the retail point of view, a multichannel concept essential for retailers due to Internet domination has changed and will continue to change the retail industry in the coming years. Currently, more retailers have been entering this highly profitable channel, outcomes in e-commerce having significantly grown over the past few years. With at the rate traditional retail channel are also a very confident with future expectation. The fashion industry is slower than other industries to adopt e-commerce applications, the main reason being that it is difficult to transform the within a store experience into an online environment. Cloths needs a lot of high buyer's participation, product segment, and products realized or touched, which was harder to experience online. Specifically, Fashion retailers who decide to follow this rapid business model are usually reluctant to go online, when it comes to traditional retail, new consumers making a regular visit to a retailer store to evaluate the products (Blázquez, 2012). To connect the gap between the channels, various technologies evolved to be a bridge for different channels, for instance, augmented reality and 3D virtual implementation to improve the traditional retail shopping performance, have changed the role of the fashion retail showroom (Drapers, 2012).

Traditional retailers required huge storage facilities. However, the rise of e-commerce shopping has influenced the significance of store numbers, and this does not mean that it is already a different and distinct channel creating purchase to current retail channels, but it also includes stores (Multichannel retailing) a complete change across retail stores. There is one more new strategy called Omni-channel retailing, which intends to merge the various ways of communicating with the retailer, which allows a customer to keep a high-level of customer satisfaction across channels and enable a consumer to shift from one channel to another. The traditional retailing industry has been driven to seek innovation by the latest update technology solutions due to consumers adopting the new technologies and becoming Omni-channel consumers (Verhoef, Neslin, & Vroomen, 2007). The technologies are used by retailers to improve the shopping experience for consumers and develop performance and sales of merchants. It is important to understand how fashion retailers use technology, understand the history of online retailing and how it has changed the fashion retail market (Lazarevic, 2012). We used Porter's five forces theory to analyze and to give a clearer picture of how fashion retail industry work in India. In this report, we analyzed the factor that led to revolutionary changes in fashion retail. The application of this model to fashion retailing explores the competitive environment. Understand that achieving profitability is competitive and challenging (Porter, 1985).

## **2. STRATEGIC INNOVATION**

COVID-19 has sent shock waves through the fashion and global operations of the fashion industry. The Fashion industry interconnected global value chain has been hit hard, the distress of suppliers, and millions of workers in some poor countries have lost income. Fashion retailers and brands need to act responsibly to ensure the survival of their business during this crisis. In recent years, the industry has begun to change its outdated procurement model, characterized by long lead times, increasing order sizes, and relatively small flexibility. The COVID-19 epidemic offers the opportunity to accelerate the shift toward strategic partnerships and innovations. During the crisis, companies have forced to innovate along the fashion value chain, including design (3-D design, artificial-intelligence planning), merchandising and planning (virtual sampling, video signoffs), B2B sell-in (digital sell-in, virtual showrooms, magic mirror, etc.), sourcing and supply chain (nearshoring, vendor integration, use of ICT technologies), and consumer engagement (virtual shows, social selling). Two-thirds of the wider group of fashion partners believe that the detailed adaptation of intelligent resources will accelerate next year, and nearly 40 percent of resource managers plan to incorporate predictive analytics into their processes. People, organizations, and partners need support to create new ways of working. After all, companies need to double their efforts to build ecosystems with innovative technologies and experiment with new collaboration models. (Berg, Magnus, Haug, & Hedrich, 2020).

Digital is not just an increasingly important sales channel. This will help companies introduce cost structures and make every step of the value chain better, faster, and cheaper. For example, digitalization can enable new logistics and sales fulfilment options (through Omni-channel like click-and-collect and drive-through), promote innovative ways of getting customers and help predict and manage inventory to create a sustainable supply chain. The key to all of this is data, transparency, governance, and accuracy of have never been more important. Quality of service is always an important factor to assess the quality of service aspect at the time of purchase, we use the integrated hierarchical model of the entire service, based on the evaluation of the three dimensions of the service transaction: the quality of the communication, the quality of the physical environment, and the quality of the outcome. Accordingly, is possible to outline the following hypotheses:

**H1: Research via Omni-channel (social media, e-commerce, online marketplace, word of mouth, brick and mortar shop) is helpful when selecting a product.**

**H2: Technology, good lighting and innovative facilities in retail fashion stores are helpful.**

**H3: The quality of service influences brand image.**

The traditional retailer arouses consumer emotions while shopping in the store, which is a prominent factor for thriving among the competition. They are consumer perceptions, enhance brand identity, create an unforgettable experience, increase time spent in the store, and build a strong customer relationship. The traditional fashion retail store environment service (e.g., ambient conditions, space, and technical function) plays a significant role moulding customer's service experience.

**H4: Store design helps you to find what you need.**

Email, social media, and other digital channels have seen significant increases in usage during the crisis. Therefore, Apparel fashion brands must continue to interact with consumers, even if most consumers do not currently spend. Use digital channels to launch real, targeted communications related to health, safety, business continuity, and community building. Changes in technological environments interact quickly and closely with changes in consumer behaviour, consumer communication, and how to receive their orders. Consumers are adopting this modern technology to communicate with retailers. New websites, social media and the use of smartphones have facilitated the best relationship between retailers and consumers.

**H5: Social media is essential for the retail fashion industry.**

## **2.1 Consumers adopting new methods**

The number of factors which influence buyers are changing their approach and expression when they buy items in the retail shop. One of the impacts on fashion retail shifting is the trend towards supermarket fashion, whereby multiple varieties of goods are available in one place for example "Big bazaar" in India. Due to this fact, part of the success of supermarket shopping is providing convenient and inexpensive products, thus the consumer saves time. Consumers also appreciate this convenience in the recent growth of out-of-town shopping complexes. Analysts reveal that consumer movement is towards out-of-town shopping and away from the commercial high street (Neil, 2009), Out-of-town retailers promote a better atmosphere, more convenience, and free parking, therefore consumers feel that out-of-town is the best place for leisure time and recreation (Aloys Borgers, 2011). Economic factors decide the formation of the retail market. Importantly, the economic factor decides the ability to buy power in the market, and it guides consumers as to which type of products they are motivated to buy. Consumers are all adopting rapidly and readily new forms of technology, and many consumers use websites and mobile e-commerce as part of shopping stocks, thus encouraging retailers to provide customers with this added channel and service (Raquel, 2013).

## **2.2. Technology endeavours in retailer shop**

The fashion retailer has been rapidly adapting to Information Technology, and digital and analytics to thrive in the market. The transition to technology and the integration of various communications tools are a comparatively recent innovation to virtual markets and online businesses efficiency in India. Consumers today are well informed, referring to detailed product features, comparing fashion items on website content, design, buyers' reviews, and rating about products. Thus, retailers should use advanced analytics and ERP systems to scan consumer attitudes and adjust retail forms, pricing and promotion strategy (Amit Gugnani, 2014). Clothing is classified as a high-profile product, touched, assessed and evaluated. For retailers this is challenging because of lack of tactile online input (Workman, 2010). The development of a variant structure of *Image Interactivity Technology* (IIT) indicates that online fashion

shopping is very appealing to buyers (Yu, Lee, & Damhorst, 2012). It refers to the use of the marketing of environmental psychology and is defined as "deliberately designing a place for buyers to produce positive effects" (Kotler P. , 1972). IIT can reduce the risk of perceived productivity and increase the hedonic importance of the online shopping process (Kim & Forsythe, 2008). Moreover, virtual product experiences, as well as virtual 2D and 3D product experiences, provide displays, tactile, functional and/or behavioural simulations during product examination that offer the consumer a less product performance risk (Jihye, Leslie, & Sharron, 2008).

### 2.2.1. 3D-Body scanning technology

Another technological is 3D body scanning technology (Phoebe, 2010). Researches have proven useful in assessing various body shapes and size categories; therefore, through using body shape scanning technology we can attain an accurate understanding of the body shape measurements, the body size, and the physical classification of the consumer. 3D body scanners can perform between 160 and 200 body shape measurements to replicate the correct physical dimensions of the customer (Priya & Cynthia, 2004).

### 2.2.2. Multifunctional mirror

The interactive mirror implements the Augmented Reality are concepts well defined in literature (Olsson, Lagerstam, Karkkainen, & Vaananen, 2013). A technique of real and computer-generated digital information appears in a specific environment. The Magic-Mirror technology seems to be a normal mirror, so customers can see their own reflection; however, many of them can be used for digital advertising, videos, catwalks, and virtual games. It can incorporate with RFID technology that recognizes the wearing of a garment, and when a customer sees himself in the mirror, you can view product information or provide additional products for the specific clothing that the customer has requested. It can therefore being asked whether one is willing to adopt new technology, leading to the final hypothesis:

**H6: Do you feel comfortable with 3-D body scanning and multi-functional mirror technology being offered in a retail fashion stores?**

## 3. THEORETICAL FRAMEWORK

We used Porter's five-power model in our theoretical framework for a systematic analysis of the retailer's situation. It provides five performance models that can be used to assess the retailer's strengths and weaknesses. They are 1) threat of new entrants, 2) Consumers power, 2) Suppliers power, 4) threat of substitutes, 5) market competitors.

### 3.1. The threat of new entrants

The evolution of Internet technology has not only led to increasing the competitiveness of independent and international fashion retailers, but also to the rise of new retail business models, such as aggregators, flash sales, subscription websites, and rentals. This will increase the number of retailers competing for the same consumers (Hergeth & Helmut, 2008).

The 90% of the Indian retail market is made up of small, unorganized and family-owned stores. Now, there are some indications that the Indian government is trying to change. This is opening their economy to direct investments in the retail trade. Foreign investors have opened a single-brand retail market and multi-brand retail consortiums, which will result in a large increase in foreign investors in India. Therefore, the threat of new entrants is high (Singla, Manik, & Renu., 2013). The entry of a retailer is very simple. However, the demand for players is to deliver a strong distribution and achieve economy-level competitiveness (IBEF, 2017).

### **3.2. The bargaining power of the consumer**

The buyer's energy is high, where buyers can switch from one brand to another brand in fashion retail. Consumers will meet low search costs through the Internet search, navigation, and recommendations. As a buyer make it easier to identify low-cost suppliers through technology. This transparency increases the price of competition in the market. The growing line of products on the market and information about these niche products are enabling consumers to find and buy them. The consumer can also access the 'Long Tail' experience to develop expertise in sourcing these niche products (Srivastava, 2008). The first important strength is the bargaining power of the buyer: they can assess competitive pricing, the ease of purchase of goods, or they can switch retailers. In the case of the fashion industry, buyer power is a relatively large force (Bush, 2016).

### **3.3. The bargaining power of suppliers**

The size and purchasing power of these large retailers gives them a unique advantage over clothing manufacturers. Those influential retail buyers organize highly competitive and global split production networks (Gereffi, Humphrey, & Sturgeon., 2005). Its success depends on the ability to build mass consumption using its reliance on strong brand names and universal supply techniques. The energy enrichment of suppliers depends on the size of the sales and the intimidation of trade. Retailers are powerful when meeting the needs of buyers and in avoiding the possibilities of online threats (Ghosh, Tripathi, & Kumar, 2010). However, the bargaining power of sellers in India is due to the high number of merchants in the market. But even so, the unorganized retail market has a high commanding position because 92% of the total retail market is contributing to this (Kumar & Sanjeev, 2015). Retailers have a low switch cost, which reduces merchant's power. Giant retailers can easily change to different providers (IBEF, 2018).

### **3.4. The intensity of market competitors**

Competition in the fashion industry is increasing as many companies compete for the same customers. Competition can lead to exit from this top market, the economic situation will be difficult and competition will intensify. Competition for the top place will provide significant benefits to the customers; consequently, as price reductions strategy will be in the commonplace. The results of the technology increase the transparency of consumer prices. For example, "Grabble" is a social media fashion and business platform that allows users to create lists of custom fashion requests from many retailers. Users receive notifications when product prices are lowered on their preferred list (Kotler, 2011). The entry of foreign entrepreneurs and e-retailers intensified due to market competition and increased competitiveness of low cost customer conversion. The Indian retail sector is extremely challenged, which increases competition (IBEF, 2018).

### **3.6. The threat of substitute product or services**

The Indian fashion traditional retailer is threatened by substitute goods due to a variety of fashion brand products available online shopping (Ribeiro, Alves, & Saravanan, 2020). Retailers do not necessarily deal with a large variety of products in the same product line (Singla, Manik, & Renu., 2013). People in India cannot buy expensive things. They look substitutes for the product they require which are cheaper than other products. Thus, the Indian unorganized retailer is the biggest threat to organized business because it makes the smallest profit but sells to the majority of the population. In unorganized retail the consumer is attracted to a higher quality at a cheaper price. So, the middle and lower class prefer these cheap substitutes (Kumar & Sanjeev, 2015).

#### 4. OMNI-CHANNEL STRATEGY

The traditional retail industries has been driven to seek innovation by the latest update technology solutions due to consumers adopting the new technologies and becoming Omni\_channel consumers. Powerful search engines, advanced mobile devices and interfaces, peer-to-peer communication vehicles, and online social networking have increased the ability to reach buyers with current information. Pressure has increased on all retailers to satisfy a new "retailer- tech savvy" customer who uses multiple devices and channels to shop. There is no specific industry or retailer whose benchmark is considered a market leader victorious in the multi-channel / Omni-channel idea. Therefore, testing and error is the current method of retailers attempting to move toward an Omni-channel process. It requires research on the Omni-channel concept and the need for more investigation to fully understand the Omni-channel buyer and journey. The technologies are used by retailers to improve the shopping experience for consumers and to develop the performance and sales of retailers. It is important to understand how fashion retailers use technology, understand the history of online retailing and how it has changed the fashion retail market. Cross-channel behaviour has a closer association with an Omni-channel than the multi-channel communication but relationships between the channels and the transmission of comments provide tips for exploring the entire customer network (Niall, 2012). Although digital-focusing channels were broadcasting, traditional retail stores still did not lose their importance in the large market of Indian fashion retailers. This channel is still contributing to specific consumer segments. The Omni-channel strategy use for technological relationships, it supports a better communication flow between retailers and their customers, also between the retailers and their suppliers. More fashion retailers embraced technology-based insights in business and customers use online sources to communicate during their shopping trip (Barry & Joel, 2012). Technology is very important in creating an Omni-channel strategy to create a seamless integrated experience for customers by providing online information and offline emotional experiences; the "Best of Two Worlds" is designed to increase the buyer experience and provide the retailer with valuable information about the consumer buying process (Chris & Adam, 2014).

#### 5. RESEARCH METHODOLOGY AND DATA COLLECTION

This methodology chapter aims to establish a research strategy and action plan to address relevant hypotheses. Multiple techniques are involved in the analysis and validation of a hypothesis. The format will be explained in more detail, and the data collection, classification, and use will be described in the following sections: see also Table 1, which shows an overview of the research design.

Research Design	Methodology	Survey data research
	Methods and Techniques	Survey, Cross-Tabulation, and SPSS
Data collection and analysis	Literature	Assessed scientific articles, thesis's, conference proceedings, website on project, memorandum, contracts, government reports and legislation.
	Survey	Created in Google forms and collected through via link which I shared with my friends and friends surrounding.

*Table 1 Comprehensive of the research design*



The literature was first analysed by most citations, and those considered relevant were carefully examined. Analysis of these results was later used to follow not only the main contributors but also other authors with significant issues that were considered important. The key is to go back and find the original source, confirm that readers are right and study the insightful literature. The survey was created in google form. The hypotheses were precisely dependent on role and position in the thesis. The survey question was designed as selection choices and Likert-scale. Respondents responded within this range, such as disagree or agree. The questions were designed to avoid possible misinterpretation, or issues that could be taken out of context. There were 93 respondents participated in this survey mentioned in below as percentage wise Table 2. It was determined that the most appropriate method was the Likert-scale measure used in SPSS tools. To analyse the result we used cross-tabulation to identify the differentiation within the variable to prove that statistical difference.

Variable	Characteristics
Respondents Gender	Male-73.1% and Female-26.9%
Respondents Age	20-30 years-82.8%, 30-40 years-12.9%, and 40-50 years-4.3%
Respondents Work	Employed-69.9%, Self-Employed-11.8%, and Unemployed-18.3%
Respondents Working Time	Day-72.1%, Night-25.6%, and Weekend-2.3%
Respondents Location	Urban-83.9%, and Non-Urban-16.1%
Respondents Education	Doctorate-21.5%, School-6.5%, and University-72.0%
Respondents Marital	Married-18.3%, and Single-81.7%

*Table 2 Sample Characteristics*

## 6. DISCUSSION OF RESULTS AND CONCLUSIONS

The cross-tabulation analysis is created by using Chi-squared to test the null hypotheses of independence between rows and columns e.g. (Mansfield, 1986) (Phillips, 1995). If the test does not show significant differences, usually measured by a p-value greater than the 5% critical value, then the null hypotheses of non-difference is not rejected. *Table 3* shows survey's findings regarding consumers' behaviourism, functionalism, and experimental ideas attitudes towards traditional retail and e-commerce offered services.

Hypotheses	Corresponding respondent p-value					
	Gender	Age	Work	Location	Education	Marital
Research via Omni-channel (social media, e-commerce, online marketplace, word of mouth, brick and mortar shop) is helpful when selecting a product regardless gender, age, work, location, education, or marital.	<b>p-0.050</b>	p-0.454	p-0.638	p-0.639	p-0.172	p-0.157
Technology, good lighting and innovative facilities in retail fashion stores are helpful regardless gender, age, work, location, education, or marital.	p-0.375	p-0.643	p-0.808	p-0.130	p-0.213	p-0.468
Store design helps you to find what you need regardless gender, age, work, location, education, or marital.	p-0.991	p-0.746	p-0.418	p-0.976	p-0.511	p-0.412
Do you feel comfortable with 3-D body scanning and multi-functional mirror technology being offered in a retail fashion stores regardless gender, age, work, location, education, or marital.	p-0.142	p-0.885	<b>p-0.030</b>	p-0.551	p-0.950	p-0.304
The quality of service influences brand image regardless gender, age, work, location, education, or marital.	p-0.733	p-0.685	p-0.372	p-0.652	p-0.564	P-0.255
Social media is essential for the fashion industry regardless gender, age, work, location, education, or marital.	p-0.374	p-0.159	p-0.112	p-0.058	p-0.666	p-0.238

*Table 3 Hypotheses corresponding p-value*

Our findings suggest that different gender categories embrace Omni-channel approach while shopping. This channel help to assess and provides the possibility to choose the best shopping option. The “Work” variable result suggest likelihood to accept retailer technology endeavours, which help to reduce manual operations. Remaining variables results exhibit prevailing inconsistent mindset perhaps due to orthodox culture, fear about new technologies, particularly concerning personal data. From the survey data collected, it is possible to understood that diversified segments of Indian consumers are dissatisfied with the traditional retailers in different contexts. For instance, under the Omni-channel question, expected Gender segment, of remaining categories of that variable, expressed intricacy and dissatisfaction with the Omni-channel strategy, suggesting that this strategy has not satisfied the whole segments. Indian people have been expecting more from the retail stores in regard to technology, good lighting, store design, and innovative facilities likewise. The traditional retailer and social media are part of the main driving forces for the contemporary fashion retail industry. However, according to our survey, data suggest that Indian consumers are unsatisfied with the quality of service provided by fashion retailers. Social media has not impacted much on India’s fashion industry sales in reality, which means it has not been driving people's emotions toward fashion. This is one of the drawbacks of the fashion retail industry in India. Fashion retailers should prepare a personalized offer, from the experts of the field, to the most loyal customers, allowing to rule their top of mind and assisting to create sales. However, India need to adopt modern technology with underline regulations. This paper findings emphase that there are points where retailers should devote to technology approaches, invest in value chain, use digital and analytics across apparel value chain, and analytics for their customers in India. Therefore, the authors of this paper suggest that retailers should utilize this big opportunity to thrive in the fashion industry and facilitate the customer shopping journey, improving their experience. These results indicate an increasing digital divide. The COVID-19 crisis has widened the gap between industry leaders and the laggards, who have not regarded to invest in technology. For leaders with the ability and willingness to invest, this market trend during the pandemic time will accelerate the business and undisputed growth in the fashion retailer industry. During the COVID-19 crisis, the digitization of product development and the application of technologies has proven to be a competitive advantage to enhance the fashion retail process. The future of the retailer is that channels are not individual operations, they have to work together. For example, a store that will implement new technology to consumers, provides virtual shopping benefits in a physical environment in the business. This will encourage consumers to shop from online websites or using the mobile apps. Accordingly, integrating channels is not just a mix of technologies, but uses of new and unique possibilities that seem to be the result of this connection. How to connect new technologies and how to interact with the media is now a major challenge. With the arrival of the Omni-channel retail and the attractiveness of this digital strategy to link both retailer and consumers, there is a whole new world of business opportunities in fashion retail.

#### **LITERATURE:**

1. Aloys Borgers, C. (2011). Assessing preferences for mega shopping centres: A conjoint measurement approach. *Journal of Retailing and Consumer Services*, 322-332.
2. Amit Gugnani, K. P. (2014). *Fashion Retail Scenario in India: Trends and Market Dynamics*. India: Technopak.
3. Anil Khanna, R. K. (2018). *Smart logistics for greater competitiveness*. India: India Brand Equity Foundation and Grant Thornton India LLP.
4. Barry, R. B., & Joel, R. E. (2012). *Retail Management: A Strategic Approach 12th edition*. London: Pearson/Prentice Hall.

5. Berg, A., Magnus, K.-H., Haug, L., & Hedrich, S. (2020). *Time for change: How to use the crisis to make fashion sourcing more agile and sustainable*. Frankfurt: McKinsey & Company.
6. Blázquez, M. (2012). Fashion Shopping in Multichannel Retail: The Role of Technology in Enhancing the Customer Experience. *International Journal of Electronic Commerce*.
7. Bush, T. (2016). *Five Forces Analysis of the Fashion Retail Industry*. England: Pestle Analysis.
8. Chris, L., & Adam, V. (2014). Human-Computer vs. Consumer-Store Interaction in a Multichannel Retail Environment: Some Multidisciplinary Research Directions. *International Conference on HCI in Business* (pp. 339-349). Greece: Springer International Publishing.
9. Citrin, A. S. (2003). Consumer need for tactile input: An Internet retailing challenge. *Journal of Business Research*, 915-922.
10. Drapers. (2012). *Technology in fashion report*. London.
11. Gereffi, Humphrey, & Sturgeon. (2005). The governance of global value chains. *Review of International Political Economy*, 78-104.
12. Ghosh, P., Tripathi, V., & Kumar, A. (2010). Customer expectations of store attributes: A study of organized retail outlets in India. *Journal of Retail & Leisure Property*, 75–87.
13. Hergeth, & Helmut. (2008). The business of fashion visualizing the financial and competitive situation of fashion companies. *Journal of The Textile Institute*, 141-146.
14. IBEF. (2017). *Retail trade in India*. Delhi: India Brand Equity Foundation.
15. IBEF. (2018). *Retail India: India Brand Equity Foundation*. New Delhi: IBEF.
16. Jihye, P., Leslie, S., & Sharron, L. J. (2008). Cognitive, affective and conative responses to visual simulation: the effects of rotation in online product presentation. *Journal of Consumer Behaviour*, 72-87.
17. Keng, A. (2003). Typology of online shoppers. *Journal of Consumer Marketing*, 139-159.
18. Kim, J., & Forsythe, S. (2008). Adoption of virtual try-on technology for online apparel shopping. *Journal of Interactive Marketing*, 45-59.
19. Kotler, P. (1972). A Generic Concept of Marketing. *Journal of Marketing*, 46-54.
20. Kotler, P. (2011). *Marketing Insights from A to Z: 80 Concepts Every Manager Needs to Know*. New York: John Wiley & Sons.
21. Kumar, P., & Sanjeev. (2015). Evaluation of Indian Retail Sector with Porter's Five Competitive Forces: An Analysis. *Journal of Sales and Marketing*, 7-12.
22. Kumar, V., & Rajkumar, V. (2005). Who are the multichannel shoppers and how do they perform?: Correlates of multichannel shopping behaviour. *Journal of Interactive Marketing*, 44-62.
23. Lazarevic, V. (2012). Encouraging brand loyalty in fickle generation Y consumers. *Emerald Group Publishing Limited*, 45-61., 45-61.
24. Mansfield, E. (1986). Patents and Innovation: An empirical study. *Management Science*, 173-181.
25. Neil, A. T. (2009). Competing for the custom of small town residents: exploring the challenges and potential. *International Journal of Retail & Distribution Management*, 732-747.
26. Niall, P. (2012). Positive and negative cross-channel shopping behaviour. *Marketing Intelligence & Planning*, 83-104.
27. Olsson, T., Lagerstam, E., Karkkainen, T., & Vaananen, V. (2013). Expected user experience of mobile augmented reality services: a user study in the context of shopping centres. *Personal and Ubiquitous Computing*, 287-304.
28. Phillips, G. M. (1995). Increased debt and Industry product markets an empirical analysis. *Journal of Financial Economics*, 189-238.

29. Phoebe, A. R. (2010). Application of 3D body scanning technology to human measurement. *International Journal of Digital Content Technology and its Applications*, 11.
30. Porter, M. E. (1985). *Competitive Advantage - Creative and Sustaining Superior Performance*. New York: The Free Press.
31. Priya, D., & Cynthia, I. L. (2004). Validation of female figure identification technique (FFIT) for apparel software. *Journal of Textile and Apparel, Technology and Management*, 23.
32. Raquel, C. M. (2013). *Situational variables in online versus offline channel choice*. 347-361: Electronic Commerce Research and Application.
33. Rudrajeet Pal, A. I. (2008). *A Competitive Business Strategy Development for Market Expansion in India*. India: Nilron Group AB.
34. Shankar, V., Inman, J. J., Mantrala, M., Kelley, E., & Rizley, R. (2011). Innovations in Shopper Marketing: Current Insights and Future Research Issues. *Journal of Retailing*, 29-42.
35. Singla, Manik, P., & Renu. (2013). Qualitative Analysis of FDI in Indian Retail Industry. *International Journal of Computational Engineering & Management*, 52-55.
36. Srivastava, R. (2008). Changing retail scene in India. . *International Journal of Retail & Distribution Management*, 714-721.
37. Verhoef, P. C., Neslin, S. A., & Vroomen, B. (2007). Multichannel customer management: Understanding the research-shopper phenomenon. *International Journal of Research in Marketing*, 129-148.
38. Workman, J. E. (2010). Fashion Consumer Groups, Gender, and Need for Touch. *Clothing and Textile Research Journal*, 126-139.
39. Yu, U.-J., Lee, H.-H., & Damhorst, L. M. (2012). Exploring Multidimensions of Product Performance Risk in the Online Apparel Shopping Context: Visual, Tactile, and Trial Risks. *Clothing and Textiles Research Journal*, 251-266.

# FOOD MARKET TRENDS: THE CASES OF SPIRULINA AND BEE POLLEN

**Jose Joao Oliveira**

*ESTGA, University of Aveiro, Portugal  
jjoliveira@ua.pt*

**Humberto Ribeiro**

*GOVCOPP; ESTGA, University of Aveiro, Portugal  
hnr@ua.pt*

## **ABSTRACT**

*The food market can be regarded as increasingly dynamic since wealthier and more educated consumers are willing to pay more for quality and for healthy food. The case of spirulina and bee pollen are two fine examples of functional foods, with recognized nutritional and functional benefits. Functional food represents not only a dynamic, but a fast-rising market as well. Nevertheless, this strand of food is challenging for many of the enterprises that operate in this business, as most of consumers keep being unaware of the particularities of the functional food market. Furthermore, albeit its own challenges that must be overcome, it is important to take adequate measures, since the functional food market should not be neglected. For such to become a reality in the near future, a good strategy on marketing is needed, together with market segmentation and an improvement on the companies' technical and scientific capacity. This paper tries to summarize some of the main characteristics of the functional food market, with a particular focus on spirulina and bee pollen, highlighting their constraints and opportunities. While addressing these two products, the ways they are marketed and the current market and future trends, this paper intends to shed more light on the functional foods, which is less and less considered as a niche market, being such proved by data and by the fact the some of the largest worldwide food players are entering very seriously in the functional food business.*

**Keywords:** *Functional Food, Consumer's Behaviour, Spirulina, Bee Pollen, Food Retail Trends*

## **1. FUNCTIONAL FOOD: CONTRIBUTIONS TOWARDS A CONCEPTUAL SYSTEMATIZATION**

The food market can be regarded as increasingly dynamic as wealthier and more educated consumers are willing to pay more for healthy food. Functional food represents not only a dynamic, but a fast-rising market as well. Nevertheless, this strand of food is challenging for many of the enterprises that operate in this business, as most of consumers keep being unaware of the features of the functional food market. Before discussing this topic, it is important to mention what is considered as functional food in this paper. Using the Functional Food in Europe (FUFOSE) criteria, as mentioned by Hawkes (2004), food can be considered functional when is possible to demonstrate that affects beneficially “one or more target functions in the body, beyond adequate nutritional effects, in a way that is relevant to either an improved state of health and well-being and / or reduction of risk of disease”. Currently the focus of nutrition science focus of nutrition science is on optimizing the power of food, and functional food is increasingly fashionable nowadays, since that hence the quality of life and promotes the health. Doyon and Labrecque (2008) elaborated a classification map of functional foods, considering a two-dimensional analysis, between the physiological effect and the functional intensity.

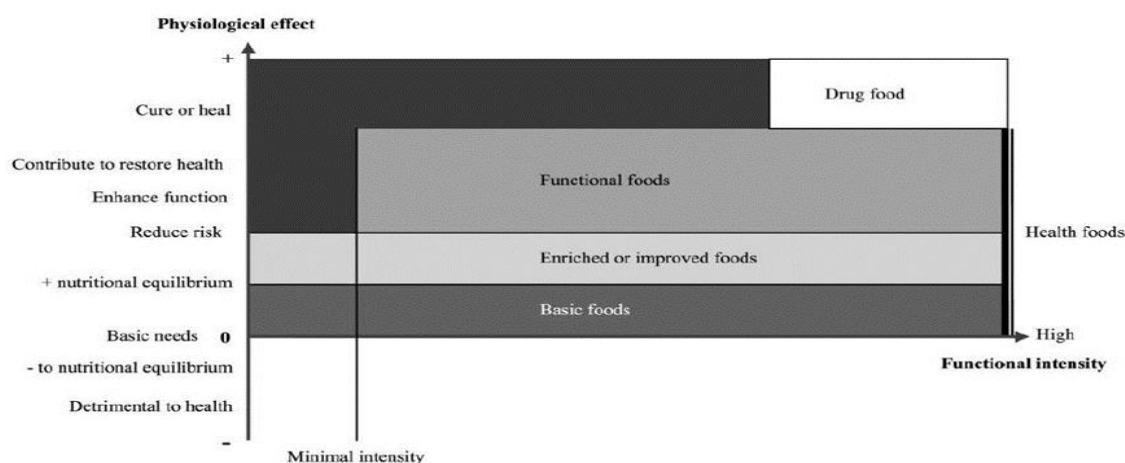

Figure 1 - Frontiers of the functional food universe  
Doyon and Labrecque (2008)

In their research, so that he could systematize the concept of functional foods, Doyon and Labrecque (2008) perform a classification of items that most settings feature. The authors emphasize on four main features: health benefits, nature of food, functional level and consumption pattern. It is acceptable as functional food, those who reduce the risk of disease and improve function and contribute to improve health. A functional food will be, according to the International Life Science Institute, some who, when consumed regularly, has a specific beneficial effect on health in addition to its nutritional properties, and this effect must be scientifically proven (Andrez, 2015). Kotilainen et al, (2006); Spence (2006) cited by Siro, Kápolna, Kápolna, and Lugasi (2008), perform a collection and systematization of the types of functional foods and their definitions. They identified four groups of types of functional foods: product fortified (eg. fruit juice with vitamin C); product enriched (eg. margarine plant sterol with prebiotics); altered products (eg. fibres in ice cream); improved products (eg. eggs with omega – 3).

## 2. CONSUMER BEHAVIOUR TOWARDS FUNCTIONAL FOODS

There are several factors that determine the acceptance of functional foods by consumers. We can divide them into two large groups: those related intrinsically to consumers and characteristics related to the product. Related to the consumers, Sääksjärvi, M. (2009) and Santeramo (2018) identified three subgroups: personal (life education, gender and age); psychological (attitudes and motives towards health); sociocultural (recommendations of health professionals, history of diseases in family, and related to the product like taste, flavour, branding and packaging). Neupane, Chimhundu, and Chan (2019) focused on a study in Australia on the cultural factors that influence the consumption of functional foods, based on large dimensions that are subdivided. Given the first great dimension, perseverance, is based on the reasons and strengths that consumers demonstrate when consuming functional foods. The authors define several aspects of perseverance that influence the consumption of functional foods:

- a) Self-directed learning - means consumers who actively and alone research on this type of products.
- b) Self-confidence - consumers want to be sure that they have made the right decision when purchasing these products, are interested in aspects of origin, type of production and ingredients.

c) Self-control over behaviours - based on perception, actions and choices regarding functional foods. Consumers who have no control over their emotions are easily transported to short-term gratification, often diverted from functional foods.

In the cultural dimension, the authors (Neupane et al., 2019) identify cultural predisposition, which means the rooting of factors that influence the modes of eating, which may or may not consciously or unconsciously favour the consumption of functional foods. Within this dimension there are several aspects:

- a) Consistency - consumers look for foods that show consistency with their traditional eating habits.
- b) Tradition - associated with a strong predisposition in the minds of consumers towards food.

The dimension of motivations is related to the reasons for consuming functional foods. The authors, Neupane et al. (2019) point out that the stronger the motivations, the less barriers there are to the consumption of functional foods. Within the motivations some sub-dimensions are identified:

- a) Stimulation - stimulation is related to the search for emotions by consumers, aiming at new sensory experiences through the consumption of functional foods, in search of a singularity. This type of consumer is not so concerned with the beneficial effects of food, but with its distinctive characteristics.
- b) Security - consumers avoid uncertainties. This type of consumer, according to the authors, divides into consumers looking for a short-term benefit, while others for a longer term. Some consumers purchase functional foods from a preventive perspective, while others because they already have health complications do so in a reactive approach.
- c) Compliance - alignment with the social groups in which they operate is very important. Since the meal is an important aspect in the societal group, it has a very significant influence capacity, which can induce the introduction / maintenance of functional foods.

Kuster-Boluda and Vidal-Chapel (2017), with a study carried out in Spain pointed out that a healthy lifestyle does not influence positively the consumption of functional foods. Siro Kapolna, Kapolna and Lugasi (2008) concluded that Europeans are more critical in using new products and food technologies. Bech-Larsen and Grunert (2003) considering the Northern Europe, stressed that health benefits are a necessary, but not sufficient for the consumption of functional foods, and Hunter, Jones, Hedderley, and Jaeger (2019) underline that the niche of people that aim to lose weight, are more sensible to functional foods.

Carrillo, Prado-Gasco Fiszman, and Varela (2013) in their study in Spain, concluded that almost of half of the respondents have no knowledge about the characteristics of functional foods; older consumers are more conservative; and women are more sensible to those products.) However, Poulsen (1999) showed exactly the opposite of a study in Denmark, we can infer that these trends are very related to the substance of the sample and the cultural / geographical scope that it is imbued. Palma et. al., (2016) underlines that 87% of functional food consumers in America perceive benefits beyond the nutritional capabilities.

### **3. FUNCTIONAL FOOD MARKET: CHALLENGES AND OPORTUNITIES**

Doyon and Labrecque (2008) stated that the worldwide market of functional food grows about 7 to 10% per year, although this is a range for defining the functional food may vary.

With regard to the market, Bleiel (2010) highlights three major general premises for the product to be successful:

- a) There must be a consumer need or problem that requires a solution.

- b) There must be awareness that the consumer or the people have a problem.
- c) Consumers must be willing to spend money to solve the problem or satisfy the need that they have identified.

Bleiel (2010) also stresses that the three premises are in effect with regard to functional foods, thus meeting the basic conditions for the success of products in general. The same author points out the emergence of many renowned brands, in adjusting to new needs and adding to the benefits of a healthier diet.



Figure 2 – McDonald’s readapting the message to healthier products  
Bleiel (2010)

The same author, through the figure below, demonstrates that currently there is a demand push at the level of functional foods, leading market forces (producers, R&D and marketing) to react accordingly and gain market share.

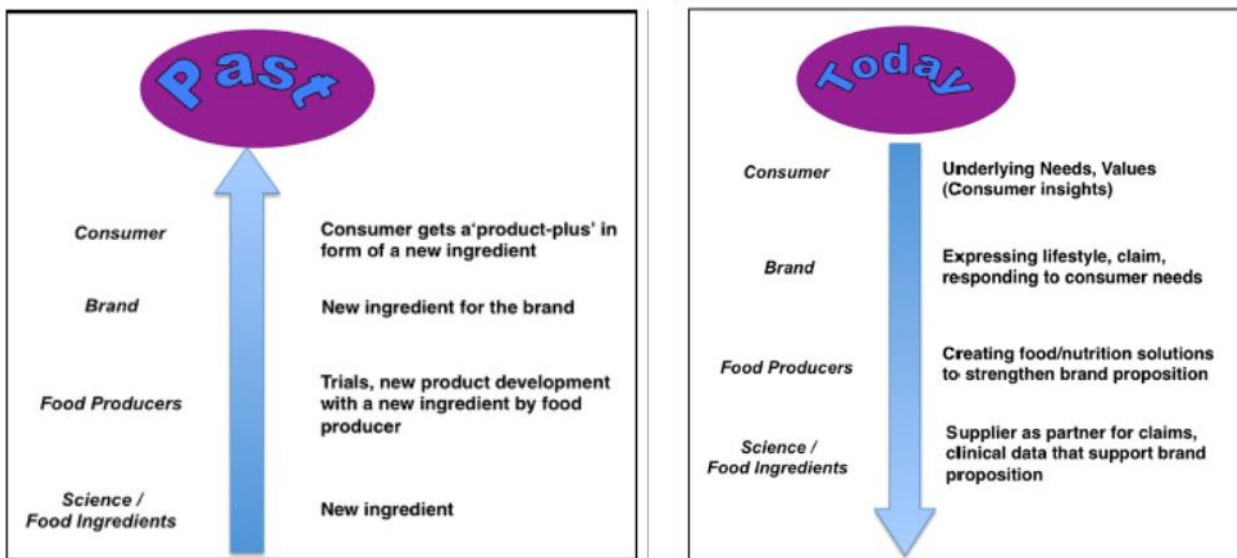

Figure 3 - Paradigms in the development of food products

Monteiro (2015) underlines that the market functional food (and drinks) in 2013 represented sales of about 43,270 millions USD. Santeramo et al. (2018) reflects on the growing of the functional food market, by stating that is an activity with risks associated, like a short life cycle



of the product (Melletim, 2014); technical difficulties (Bleiel, 2010) and the incipient knowledge of the market and acceptance of products by consumers (Van Kleef, Van Trijp, & Luning, 2005). These are factors that justify a more detailed study of the functional food's market and factors associated. Gok and Ulu Efe (2019) point out that the increase in the functional food market is mainly due to a series of critical awareness of personal health. Based on Euromonitor data, <https://www.euromonitor.com/fortified-functional-packaged-food-in-portugal/report>, assessed on April 2020, Japan is the world's largest market for this type of product, followed by the USA, with the European market appearing in third place even less developed than the previous ones. The three major markets make up more than 90% of total sales. Gok and Ulu Efe (2019) point out that there are several behaviours in the European market. Northern countries, with greater tradition in the consumption of functional foods and Mediterranean countries, favouring perishable and fresh products. Considering the data available on the euromonitor page on functional foods, the authors highlight foods enriched with protein, associated with a healthier lifestyle, as well as the continued focus on products rich in fiber and enriched at the level of dairy products, in specifically yogurts. It is also underlined that the industry focuses its actions on natural segments, and that fortified and functional packaged foods still have growth potential.

In the Portuguese case we can refer one or two examples of successful companies that bet on functional and sports nutrition. Prozis, basing its action on online, the turnover continues to grow 60 million euros in 2016; 84 million euros in 2017 and 120 million euros in 2018 (estimate) in a market that worldwide is evaluated in 55 to 60 billion euros (Sousa, A. 2019). Iswari is another Portuguese company that continues to grow substantially. It earned 6.6 million euros in 2017, increase of 52% over the previous year (Barbosa, M; Nunes, P. 2019). The changes in socio-demographic context, the innovation in the world of retail, challenges the companies to innovate and find new products. Nevertheless, the behaviour of consumers, climate changes, population growth, rationalization of resources, all together bring new challenges and simultaneously opportunities. Szakály, Kovacs, Peto Huszka and Kiss (2019) highlight several challenges in the functional food market, like development and production of the products, the acceptance of the public, that could lead to neophobia. Studying the Spanish market, Kuster-Boluda and Vidal-Chapel (2017) indicates several steps that the companies should take to be successful, focusing in promoting the benefits and safety of functional foods generating confidence in the consumers; technical specifications of the products to be visible and legible; focused marketing campaigns; transparency to the consumer (eg packaging and labelling); segment the product(s) to the market(s). Carrillo et al. (2013) also states that a good labelling, produces positive correlation with the customer.

Several challenges are inherent to the development of the market of functional food, namely inbound, like academic and regulatory areas, new forms of management, supporting technologies, creation of internal skills, consulting external and innovative sources, brand building and others (Kotilainen et al, 2006). The 2019 Euromonitor report (Shridhar, 2019) - Using Consumer Types to Understand the Path to Purchase, divides consumers into ten major segments, and points out the main causes of consumption for each consumer segment. The main reason for consuming a product, in nine of the ten consumer segments, is the desire to try new products or services, with variations naturally in the different segments. We can conclude that it is extremely important, as functional foods do not have a very strong market penetration, they may have a substantial growth potential in the consumer market, namely spirulina and bee pollen. Considering the type of influence or channel most important to the diversity of customers, it appears that the Recommendations of Family and Friends and the Independent Evaluation of Consumers are the most important factors. Naturally, when we replicate these

trends in functional nutrition, these results, although they may indicate benefits in terms of word of mouth and close or indirect recommendations, we also have to consider the specific sector in which we are located, with variations in factors occurring. To achieve success on the market as specific as the functional foods, companies should adjust their designs capabilities to emphasize the nutrient and disease prevention capabilities. Adjust the products to the concerns of the consumer's, and their supply (Van Kleef et al., 2005; Siro et al., 2008).

#### 4. SPIRULINA AS A CASE STUDY

##### 4.1 Spirulina's Product Description

Spirulina production is seen as a viable alternative to proteins of animal origin due to the minor impacts on the environment, water and arable soil (Grahl, Strack, Weinrich, & Morlein, 2018). Products derived from microalgae can be sold as supplements, in isolation and extracted directly from the primary source. Another form of commercialization is to increase the primary form (microalgae) in existing foods, in order to enrich them nutritionally, such as drinks, yoghurts, snacks, cookies, protein bars, cereals, among others (Vigani et al., 2015). Spirulina is one of the most recognized microalgae and used in human food / supplementation, animal feeding, biofuel production with recognized environmental benefits (Draaisma et al., 2013; Koyande et al., 2019). The demand for functional foods has been increasing in recent decades, due to consumers' awareness of the positive impacts on their health, derived from the consumption of these products. However, the use of algae and spirulina is still at an embryonic stage, especially in the European context. This scenario results from several factors, namely those associated with production costs, when compared to other sources of protein (algae compared to lupins or soybeans); food security issues; scale of production and acceptance by the consumer market (Camacho, Macedo, & Malcata, 2019). Grahl et al. (2018) point out that the development of spirulina as a consumable product is still incipient, due to the limited knowledge about the application in recipes and the scarcity of offer of convenience products in supermarkets. The offer of this product and its consumption is mainly centred as a food supplement, additive or colour, being sold in the form of powder, tablets or capsules. The same authors point out that there is an urgent need to rethink the strategy of product innovation, namely the incorporation of spirulina in other forms, especially incorporated in foods and greater convenience.



Figure 4 – Powder Spirulina



Figure 5 – Spirulina in pills



Figure 6 – Spirulina Cereal bar



Figure 7 – Sushi of Spirulina

One of the innovative ways of consuming spirulina is through incorporation into other foods. Sushi for example is a type of food that is made with seaweed, with spirulina being a suitable product, you can innovate with a ready-to-eat product. One of the ways of greater democratization of spirulina may be to incorporate this product in protein and cereal bars, increasing the nutritional value of these foods. This product category deserves special mention as one of the nine trends that influence the market.

#### 4.2 Spirulina Market

The global spirulina market is expected to show an annual growth rate of 10%, until 2026, and it is estimated that in that year it will be valued at about 2 billion dollars. In 2016 this market represented around 700 million dollars. Due to a wide range of uses, such as food supplement, animal food, cosmetics and natural colouring. Due to restrictive uses of artificial colors in the European Union, demand for spirulina is expected to increase for this use.

Many developed and developing countries are actively supporting the local spirulina market, creating the conditions for its production in an integrated manner.

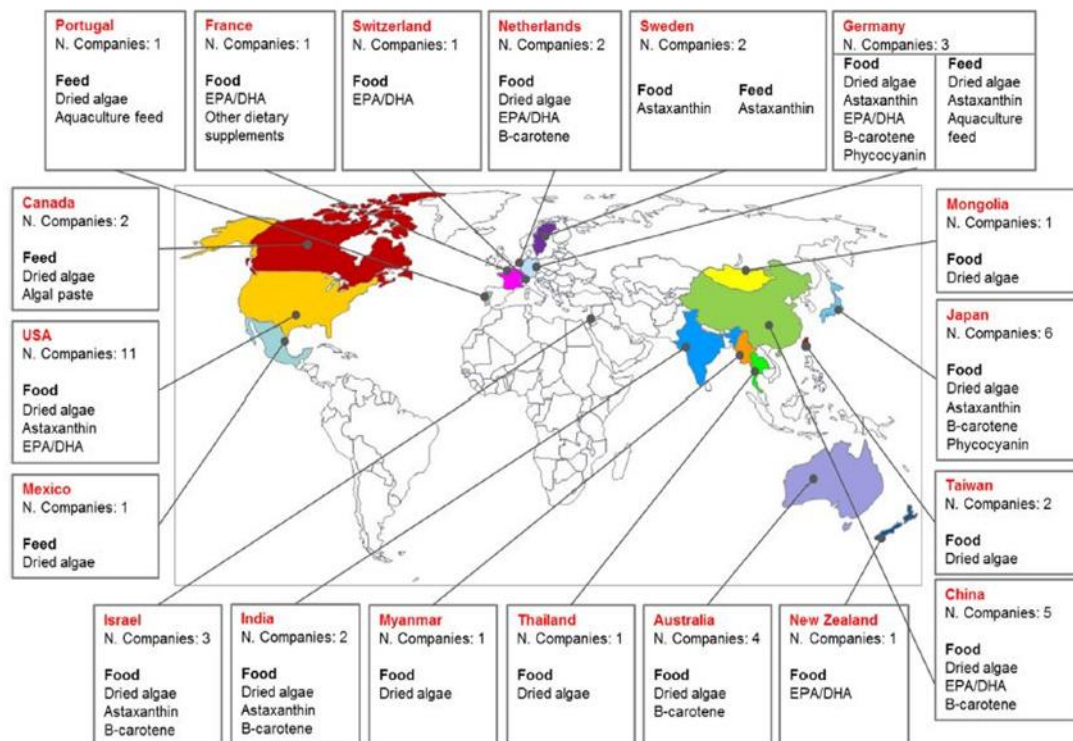

Figure 8 - Map of Microalgae Producers (Spirulina and Chlorella). Vigani et al. (2015)

In addition to the paradigm shift in production, there is also an increasing demand for this type of product in the consumer market. The trend is increasingly to be more natural and healthy, an example of this is the constant innovation in this market fringe: Naked Juice launched a juice based on spirulina. Persistence Market Research's report on spirulina, available on <https://www.persistencemarketresearch.com/market-research/spirulina-market.asp>, indicates that the main trends in the global market are the production of ready-to-drink smoothies. The same report points out that North America by 2026 will be the largest market for spirulina, valued at \$ 570 million and the highest CAGR will be 11.5%. Both the European market and Asia and the Pacific will also show remarkable growth. The same study highlights leading companies in this field, such as Cyanotech Corp., DDW Inc., Sensient Technologies Corp., GNC Holdings, Inc., based in the USA. Health Group Inc. is recognized as some of the leading

spirulina manufacturers in the world. Other key players profiled in the report include: GNT Holdings B.V., Fuqing King Dnarmsa Spirulina Co., Ltd., Dongtai City Spirulina. Mars itself is developing products based on spirulina, which has also sparked the interest of other food companies.

## 5. BEE POLLEN AS A CASE STUDY

### 5.1 Bee Pollen's Product Description

Bee pollen derives from pollen that is collected by bees at the time of flowering. This product combines small amounts of the bee's saliva and the nectar it takes from the flowers.



Figure 9 - Bee Pollen Grains

The organoleptic characteristics and the chemical constituents of pollen can vary due to several factors, the most important of which are: the climate, seasons and the type of flora. If the climate is hot and humid and gives rise to a high forest diversity, we may have a multifloral pollen, based on a greater diversity of flowers. If the climate is more varied, and with less tree / plant diversity, we will have a monofloral / unifloral pollen. Multifloral pollens tend to be richer. Even within the same crop, with very similar natural factors, there may be organoleptic differences (grain size, color) and product properties (Negrao & Orsi, 2018).

According to (FNA), 2010) National Beekeepers Federation, in its Pollen and Propolis Production Manual, bee pollen has the following characteristics:

	<b>POLLEN COLLECTED BY MEN</b>	<b>POLLEN COLLECTED BY BEES</b>
<b>WATER</b>	9,7	11,2
<b>GROSS PROTEIN</b>	20,4	21,6
<b>OTHER EXTRACTS</b>	5,0	5,0
<b>CARBON HYDRATES</b>	19,4	31
<b>ASHES</b>	3,5	2,7
<b>NOT IDENTIFIED</b>	42,9	28,6

Table 1 – Pollen Composition Adapted from FNA 2010 - Pollen and Propolis Production Manual

Other factors are related to extraction methods, storage conditions and fresh pollen treatment processes that can influence the final quality of the product. Bee pollen has been used for centuries by different cultures and is known to be a superfood due to its high nutritional content (Salazar-Gonzalez et al., 2018). Bee pollen is considered a natural food with a wide variety of therapeutic properties, including antimicrobial, antifungal, antioxidant, anti-radiation, hepatoprotective, chemoprotective and / or chemopreventive and anti-inflammatory activities. In addition, it has been associated with triggering beneficial effects in the prevention of prostate

problems, arteriosclerosis, gastroenteritis, respiratory diseases, desensitization to allergies, improving the cardiovascular and digestive systems, body immunity and delaying aging, as well as increased tissue repair and mitotic rate (F. Li et al., 2019). The most beneficial aspects of bee pollen are the antibacterial and antioxidant effects that give it added value as a functional food. These nutritional and therapeutic properties based on phenolic compounds, such as gallic, caffeic and cinnamic acid, as well as flavonoids associated with anti-oxidative characteristics (Karadal et al., 2018); (Kostić et al., 2019).

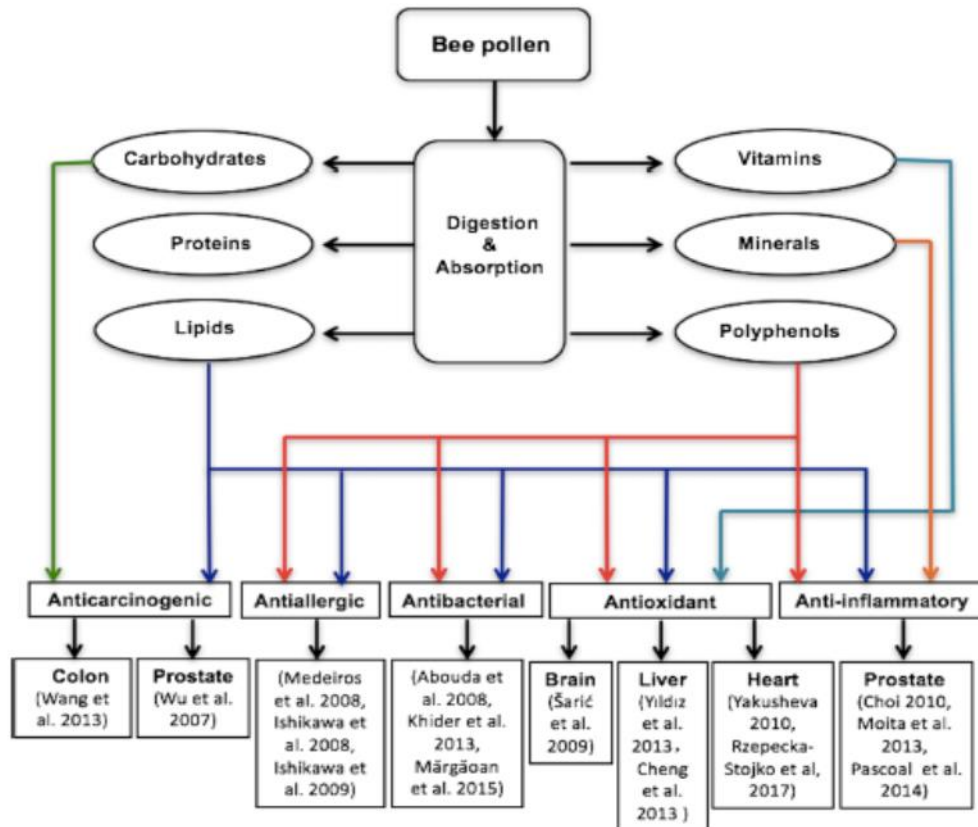

Figure 9 - Therapeutic potential of Bee Pollen  
Li et al. (2018)

In its reference, the FNA (2010) alludes to several advantages of the bee pollen product, namely, essential amino acids (not synthesizable by the body), such as lysine, tryptophan, histidine, leucine, isoleucine, methionine, phenylalanine. Also by growth-promoting amino acids, such as arginine, cystine and tyrosine. Below is a brief description of these compounds and their action on the body:

- Alisin contributes to calcium fixation, stimulates appetite, facilitates digestion and promotes the renewal of red blood cells.
- Tryptophan allows the assimilation of vitamin B3, the deficiency of which causes Pellagra (that can lead to death);
- Arginine fights impotence;
- Histidine favours the formation of hemoglobin;
- Cystine contributes to the improvement of skin elasticity;
- Tyrosine protects the skin against solar radiation;
- Leucine facilitates the proper functioning of the pancreas;
- Methionine favours the liver and digestive system in general;

Other known pollen constituents:

- Vitamins in group B, C, D, E, and Provitamin A;
- Most mineral salts: calcium, potassium, magnesium, phosphorus and numerous trace elements;
- Some enzymes that favour the metabolism of important organic functions;
- Different pigments. (FNA), 2010)

Bee pollen, seen as a functional food, has abundant nutritional properties, including proteins, polysaccharides and lipids. The average protein content in bee pollen is 24.65% (10-40% by dry weight). The proportion of amino acids in bee pollen is also high, with great diversity. The protein in bee pollen is responsible for 29.18% of its dry weight; polysaccharides, that is, carbohydrates, are the most abundant component in bee pollen, representing 18.9-57.6% of bee pollen. Lipids are an important component of bee pollen and their content is responsible for about 1 to 20% of its dry weight. Other trace elements, including vitamins, minerals, enzymes, nucleic acids, have also been found in pollen. Therefore, it has antioxidants, anti-inflammatories and immune enhancement resources (Pascoal, Rodrigues, Teixeira, Feás, & Estevinho, 2014); (Q. Q. Li et al., 2018); (F. Li et al., 2019).

## 5.2. Bee Pollen Market

Currently, natural food products, whose nutritional value is recognized, are experiencing a resurgence. Consumers' expectations regarding food are increasing, particularly in the segments of functional and health-beneficial products, both prophylactically and in helping to combat certain diseases. Food producers are also aligned with this healthier trend, of “what we are what we eat”. Bee products, namely bee pollen, are part of this philosophy, with a market to explore and grow (Kieliszek et al., 2018). With regard to the bee pollen market, and because it is a specific area and often dominated by small and micro companies, it is more difficult to obtain market size data and projections. According to Marketwatch.com, the bee pollen market segment is expected to grow at an annual growth rate of approximately 6% over the next five years, reaching a mark of \$ 720 million in 2024. The Asia-Pacific region occupied about 1/3 of the global bee pollen market in 2016, with North America second and Europe third. [www.marketwatch.com/press-release/bee-pollen-market-2019-global-industry-insights-by-global-share-emerging-trends-regional-analysis-segments-prime-players-drivers-growth-factor-and-foreseen-till-2024-2019-09-25](http://www.marketwatch.com/press-release/bee-pollen-market-2019-global-industry-insights-by-global-share-emerging-trends-regional-analysis-segments-prime-players-drivers-growth-factor-and-foreseen-till-2024-2019-09-25) (consulted on 10/03/2020).

The New Zealand company Comvita with 1.68% of the market, in 2016 ranked first in terms of revenue share in the global bee pollen market, followed by Stakich (North American) with around 1.57%. As previously mentioned, there is a huge polarization of small producers of this product, which may appear as an opportunity for market growth. In its statement on the study of this market, “Marketwatch” points out that all small producers that are not studied in the report, would correspond to about 81% of the global market in 2016.

The bee pollen market goes beyond the food segment, also covering sectors such as health products, cosmetics and others.

## 6. CONCLUSION

In this paper we discussed theoretical aspects of functional nutrition and the associated factors, external and internal to companies, focusing on the criteria of success in the business world, namely the measures that companies must address in order to be successful. Furthermore, the functional food market cannot be neglected, although it has its own challenges that must be overcome. For such to become a reality in the near future, a good strategy on marketing is needed, together with market segmentation and an improvement on the companies' technical and scientific capacity. This paper tried to summarize some of the main characteristics of the

functional food market, with a particular focus on spirulina and bee pollen, highlighting their constraints and opportunities. Spirulina and bee pollen are two products with recognized nutritional and functional capabilities, but which, nevertheless, need an improvement in the way of communicating with the customer and a new, more innovative approach, by the food industry. While addressing these two products, the ways they are marketed and the current market and future trends, this paper intended to shed more light on the functional foods, which is less and less considered as a niche market, being such proved by data and by the fact the some of the largest worldwide food players are entering very seriously in the functional food business. Finally, this paper aims to present and bring to the discussion some precursors and theoretical foundations that will base a future empirical study, based on market research. The future research will focus on the Portuguese assessment of functional food market, in particular in regard to spirulina and bee pollen.

#### LITERATURE:

1. Andrez, J. H. A. (2015). Suplementos Alimentares: Mercado Global e Estratégias de Marketing Instituto Superior de Ciências da Saúde Egas Moniz.
2. Barbosa, M; Nunes, P.; retrieved on March, 18, 2019 from: <https://eco.sapo.pt/2018/02/19/portuguesa-iswari-dispara-em-2017-vende-7-200-produtos-por-dia/>
3. Bech-Larsen, T.; Grunert, K. G, (2003) The perceived healthiness of functional foods: A conjoint study of Danish, Finnish and American consumers' perception of functional foods, *Appetite*, 40 (1), 9-14.
4. Bleiel, J. (2010). Functional foods from the perspective of the consumer: How to make it a success? *International Dairy Journal*, 20 (4), 303–306.
5. Camacho, F., Macedo, A., & Malcata, F. (2019). Potential Industrial Applications and Commercialization of Microalgae in the Functional Food and Feed Industries: A Short Review. *Marine Drugs*, 17(6) 1-25 .
6. Carrillo, E, Fiszman, S., & Varela, P. (2013). Why buying functional foods? Understanding spending behavior through structural equation modelling. *Food Research International*, 50 (1), 361-368.
7. Doyon, M., & Labrecque, J. (2008). Functional Foods: The Concept Definition, 110 (vol.).
8. Draaisma, R. B., Wijffels, R. H., Slegers, P. M., Brentner, L. B., Roy, A., & Barbosa, M. J. (2013). Food commodities from microalgae. *Current Opinion in Biotechnology*, 24(2), 169-177.
9. FNA, F. N. d. A. (2010). Manual de Produção de Pólen e Propolis
10. Gok, I., & Ulu Efe, K. (2019). Functional foods in Turkey: marketing, consumer awareness and regulatory aspects. *Nutrition & Food Science*, 49(4), 668-686.
11. Grahl, S., Strack, M., Weinrich, R., & Morlein, D. (2018). Consumer-Oriented Product Development: The Conceptualization of Novel Food Products Based on Spirulina (*Arthrospira platensis*) and Resulting Consumer Expectations. *Journal of Food Quality*, 1-11
12. Hawkes C. (2004). Nutrition labels and health claims. The global regulatory environment. World Health Organization, 1- 88
13. Hunter, DC Jones, VS, Hedderley, DI, & Jaeger, SR (2019). The influence of claims of appetite control benefits in those trying to lose or maintain weight: The role of claim believability and attitudes to functional foods. *Food Research International*, 119, 715-724.
14. Karadal, F., Onmaz, N. E., Abay, S., Yildirim, Y., Al, S., Tatyuz, I., & Akcay, A. (2018). A Study of Antibacterial and Antioxidant Activities of Bee Products: Propolis, Pollen and Honey Samples. *Ethiopian Journal of Health Development*, 32(2), 116-122

15. Kieliszek, M., Piwowarek, K., Kot, A. M., Błażej, S., Chlebowska-Śmigiel, A., & Wolska, I. (2018). Pollen and bee bread as new health-oriented products: A review. *Trends in Food Science & Technology*, 71, 170-180.
16. Kostić, A. Ž., Milinčić, D. D., Gašić, U. M., Nedić, N., Stanojević, S. P., Tešić, Ž. L., & Pešić, M. B. (2019). Polyphenolic profile and antioxidant properties of bee-collected pollen from sunflower (*Helianthus annuus* L.) plant. *LWT*, 112, 108244; 1-7
17. Kotilainen, L., Rajalahti, R., Ragasa, C., & Pehu, E. (2006). Health enhancing foods: Opportunities for strengthening the sector in developing countries. *Agriculture and Rural Development Discussion Paper* 30
18. Koyande, A. K., Chew, K. W., Rambabu, K., Tao, Y., Chu, D. T., & Show, P. L. (2019). Microalgae: A potential alternative to health supplementation for humans. *Food Science and Human Wellness*, 8(1), 16-24.
19. Kuster-Boluda, I., Vidal & Chapel, I. (2017). Consumer attitudes in the election of functional foods. *Spanish Journal of Marketing - ESIC*, 21 (Supplement 1), 65-79.
20. Li, F., Guo, S., Zhang, S. S., Peng, S. N., Cao, W., Ho, C. T., & Bai, N. S. (2019). Bioactive Constituents of *F. esculentum* Bee Pollen and Quantitative Analysis of Samples Collected from Seven Areas by HPLC. *Molecules*, 24, 1-15
21. Li, Q. Q., Wang, K., Marcucci, M. C., Sawaya, A., Hu, L., Xue, X. F., . . . Hu, F. L. (2018). Nutrient-rich bee pollen: A treasure trove of active natural metabolites. *Journal of Functional Foods*, 49, 472-484.
22. Monteiro, P. (2015). Functional Foods: sociological framework and consumer habits. *CIES e-Working Paper No. 200*, 25.
23. Negrao, A. F., & Orsi, R. O. (2018). Harvesting Season and Botanical Origin Interferes in Production and Nutritional Composition of Bee Pollen. *Anais Da Academia Brasileira De Ciencias*, 90(1), 325-332
24. Neupane, S., Chimhundu, R., & Chan, K. C. (2019). Cultural values affect functional food perception. *British Food Journal*, 121(8), 1700-1714.
25. Nina Urala, Liisa Lähteenmäki, (2003) "Reasons behind consumers' functional food choices", *Nutrition & Food Science*, 33 (4), 148-158
26. Palma, MA, Shore, LA, & Knutson, RD (2016). The Era of the Functional Consumer. *Journal of Food Products Marketing*, 22 (5), 555-570.
27. Pascoal, A., Rodrigues, S., Teixeira, A., Feás, X., & Estevinho, L. M. (2014). Biological activities of commercial bee pollens: Antimicrobial, antimutagenic, antioxidant and anti-inflammatory. *Food and Chemical Toxicology*, 63, 233-239.
28. Pereira, A. (2014) Trabalho final do 6º ano médico com vista à atribuição do Grau de mestre no âmbito do ciclo de estudos de mestrado Integrado em medicina, Alimentos Funcionais. Faculdade de Medicina da Universidade de Coimbra.
29. Poulsen, J. B. (1999). Danish consumers' attitudes towards functional foods. Working paper 62, MAPP, The Aarhus School of Business, Denmark
30. Sääksjärvi, Maria & Holmlund, Maria & Tanskanen, Nina. (2009). Consumer knowledge of functional foods. *The International Review of Retail, Distribution and Consumer Research*. 19, 135-156.
31. Salazar-Gonzalez, C. Y., Rodriguez-Pulido, F. J., Terrab, A., Diaz-Moreno, C., Fuenmayor, C. A., & Heredia, F. J. (2018). Analysis of Multifloral Bee Pollen Pellets by Advanced Digital Imaging Applied to Functional Food Ingredients. *Plant Foods for Human Nutrition*, 73(4), 328-335.
32. Santeramo, FG, Carlucci, D., De Devitiis B, Seccia, A., Stasi, A. Viscecchia, R., & Nardone, G. (2018). Emerging trends in European food, diets and food industry. *Food Research International*, 104, 39-47.



33. Shridhar, A. (2019). Using Consumer Types to Understand the Path to Purchase; Euromonitor Report; 1-41.
34. Siro, I., Kápolna, E., Kápolna, B. & Lugasi, A. (2008). Functional food. Product development, marketing and consumer acceptance-A review. *Appetite* 51 (3), 456-467.
35. Sousa, A. Prozis: das lesões desportivas até à economia global. Retrieved on March, 19, 2019 from: <https://jornaleconomico.sapo.pt/noticias/prozis-das-lesoes-desportivas-ate-a-economia-global-394545>
36. Spence, J. T. (2006). Challenges related to the composition of functional foods. *Journal of Food Composition and Analysis*, 19, S4–S6
37. Szakály Z. Kovacs S, Peto K., Huszka, P., & Kiss, M. (2019). A modified model of the willingness to pay for functional foods. *Appetite*, 138, 94-101.
38. Van Kleef, E., Van Trijp, H. C. M., & Luning, P. (2005). Functional foods: Health claimfood product compatibility and the impact of health claim framing on consumer evaluation. *Appetite*, 44, 299–308.
39. Vida Económica, retrieved on March, 19, 2019 from: <https://www.agroportal.pt/wp-content/uploads/agrovida-julho-2017-br.pdf>
40. Vigani, M., Parisi, C., Rodríguez-Cerezo, E., Barbosa, M. J., Sijtsma, L., Ploeg, M., & Enzing, C. (2015). Food and feed products from micro-algae: Market opportunities and challenges for the EU. *Trends in Food Science & Technology*, 42(1), 81-92.

## DETERMINING THE AMOUNT OF LOST PROFIT IN EXPERT EVIDENCE

**Iveta Sedlakova**

*University of Zilina, Slovakia*

*Iveta.sedlakova@fpedas.uniza.sk*

### **ABSTRACT**

*Lost profits, damage and various forms of damage are problems that a company may encounter during its existence for various reasons. For many topics, it is necessary to clearly identify the methods of their calculation. It is possible to look at the topic of lost profit from various points of view. From the point of view of the injured party, from the point of view of the expert who is to calculate the amount of lost profit and from the point of view of the judge who is to decide on the correctness of the calculation and on the result. The quantification of lost profits is a problem in terms of the assignment itself, but it becomes extremely interesting in the process of expert evidence. The result of this process and the work of an expert is an expert act, which can take various forms, the most important being the form of an expert testimony and opinion. The expert testimony and opinion have to be in all respects provable and usable also for proceedings before a court or other public authority. The author aims to name the boundary conditions, which are the basis for the selection of the optimal method of calculation and which are applicable to different cases. The topic of lost profit in the process of expert evidence has an interdisciplinary character, which represents an intertwining of economic, technical and legal problems. The methods of calculating the determination of the amount of lost profit are based on methodological principles of company valuation with emphasis on the principle of income, property and comparison.*

**Keywords:** *company, damage, expert opinion, financial lost, lost profit*

### **1. INTRODUCTION**

Every serious business entity aims to make a profit, minimize its costs and also to act in such a way that it does not cause damage or any form of damage by its actions to another business entity. Despite our efforts, however, there are situations where such a problem arises. The reasons can be different. Frequent reasons are breach or withdrawal from the contractual relationship, breach of business conditions, unfair competition, unforeseen interventions that cause disruption of operations, theft, breach of work discipline, etc. On the other hand, a business entity that feels damaged must take all steps to prevent damage, minimize it (Brabenec, T. 2010). It is up to the injured party to prove the burden of proving that he has suffered damage and possibly lost profit, and also to quantify the amount of damage and lost profit. Another question is if there was damage and lost profit, who caused it, when and how (Kundelis, E., & Legenzova, R. 2019). By the CISG-AC (2006) "damages for breach of contract by one party consist of a sum equal to the loss, including loss of profit, suffered by the other party as a consequence of the breach. Such damages may not exceed the loss which the party in breach foresaw or ought to have foreseen at the time of the conclusion of the contract, in the light of the facts and matters of which he then knew or ought to have known, as a possible consequence of the breach of contract". The issue of quantifying lost profits and damages can be viewed from several perspectives. From the point of view of the injured party, from the point of view of the person who caused the damage, from the point of view of the judge who is to decide the dispute and from the point of view of an independent expert, the expert who has the damage and lost profit. The aim of the paper is to present the view of an independent expert, an expert economist, who will prepare an expert opinion on the problem. This report, as a result of expert evidence, is the evidence for the judge's decision.

Its formal, methodological and content page must be prepared in accordance with the applicable legislation of the country, in this case the Slovak Republic. Slovak legislation contains legal regulations concerning expert activities as well as methodological procedures of an expert in the valuation of property and business. The Ministry of Justice of the Slovak Republic supervises the expert activity.

## **2. THEORETICAL BACKGROUND**

Expert activity and conditions of its performance are regulated mainly by Act no. 382/2004 Coll. about experts, interpreters and translators of The Slovak Republic (2020) and Decree of the Ministry of Justice of the Slovak Republic no. 228/2018, which will implement the Act on Experts, Interpreters and Translators (2018). Pursuant to this legal regulation §16, expert activity is defined as specialized professional activity. The expert must carry out the expert activity in person, properly, within a specified period of time, purposefully, economically and impartially. The output of the expert's work is an expert opinion, which has the exact requirements, formal and content. Pursuant to § 17 of the Act on Experts, the overall composition of the expert opinion must make it possible to examine its content and verify the justification of the procedures. It is necessary to analyse the problem that is solved in the report, find the optimal method for its solution and justify this chosen method. The methods described in Annex no. 1 of the Decree of the Ministry of Justice no. 492/2004 Coll. on the determination of the general value of assets are used in the valuation of assets and valuation of the company. The essence of expert evidence, the subject of which is real damage, lost profit, financial damage is related to several basic concepts. These include objectification, which is an expert determination of the general value of assets, taking into account the technical condition, market influence, economic influences and other specific factors. Through the process of objectification, the expert changes the initial value to the final value using the given methods. He/she will objectively assess the studied phenomenon, find out its causes and consequences. As financial damage is a specific problem, the solution of which goes beyond the scope of the procedures specified in the decree, specific factors have a significant influence in the process of objectification. These will then affect the choice of method and the overall progress of the solution. Each case is specific, different, because the causes of the damage event are different, business entities are different, the examined periods of the consequences of events are different (Sedláková, I. 2012b). Another term is a depleted source. It is a monetary expression of the benefit generated principally from disposable gains, revenues or the balance of cash flows. It is obtained from the activities of the company or its parts, or from the components of the company's assets. Its amount depends on the past development of the company, on its current position on the market, but especially on its expected development (Németh, E., Zsótér, B. 2019). A depleted source is a benefit that can be drawn from an enterprise without disrupting its core business. The company is able to create such benefits in conditions of growth and stabilization without negative effects. The intervention of a loss event interrupts or completely stops the creation of depleted sources. These unattainable depleted sources are the essence of quantifying lost profits. Future developments, which follow on from past developments, are the basis for further procedures of expert evidence. Especially for companies with history, it is possible to apply the procedure of capitalization of depleted sources for the evaluated period of time (Belas, J., Smrcka, L., Gavurova, B., Dvorsky, J. 2018), i.e. the yield principle of valuation. It is assumed that in the future the company would achieve at least the same depleted source, profit as in the past, if its activities were not interrupted by a loss event. The future of a company or project is part of a business and financial plan (Durica, M., Podhorska, I., Durana, P. 2019). The reality of the plan is verified by an expert by analysing historical data. Significant in its assessment is the fact that under comparable, unchanged conditions it is not possible to expect significant changes.

If the company reported a loss or made a small profit in the normal course of business, it is not realistic to assume that the loss event prevented it from making a significant profit (Siekelova, A., Kollar, B., Weissova, I. 2015). If it is not possible to analyse the past development because it is a newly established company or a planned unrealized project, then the application of the comparative principle is possible, e.g. it compares an undertaking or project with a similar undertaking or project at a given place and time in a comparable activity, in the same sector and with the same legal form. Thus, comparable creation of depleted sources or profit under comparable conditions is assumed (Hájek P., Zhunisova G., Oralbaeva Z., Zhidebekkyzy A., Baidildina A. 2019). When determining the value of the component of the company's assets, the procedure is always taken into account the peculiarities and technical - economic determination of this component of assets. The components of the company's assets are meant e.g. real estate, technology, inventories, receivables (Susanto, Y.K., Adriane, Sh., Pirezada, K. 2019). The nature and characteristics of the components of the asset affect which expert is competent to evaluate or otherwise assess the components. When applying the methods and procedures, the expert should give preference to a procedure that corresponds to the relevant state of science and knowledge in the given field in accordance with the valid legal regulations (Sedláková, I. 2012a). As already indicated, the terms lost profit, damage, financial damage and the methodology of calculating the determination of their amount Decree of the Ministry of Justice of the Slovak Republic no. 492/2004 Coll. it does not directly solve and cannot solve, because it is not possible to set the general procedure of calculation of such a complex issue with selected algorithms. Therefore, a high level of expertise of the expert is necessary in order to choose the right methodological procedure, which reflects the essence of the solved problem. The condition is to define and understand the concepts of damage and lost profit, which from an economic point of view represent the overall financial damage.

Act no. 513/1991 Coll. The Commercial Code, as amended in §380, is considered to be damage caused to the injured party by having to incur costs as a result of a breach of the other party's obligations. In § 381, this Act states that instead of the actually lost profit, the injured party may demand compensation for the profit achieved, as a rule, in fair trade under conditions similar to those of the breached contract in the area of business in which it operates. In this case, it is therefore an abstract lost profit, which can be determined by comparison with a similar pre-existing activity. Experts consider this procedure if it is necessary to determine the lost profit for a project that was planned and wasted. Act no. 300/2005 Penal Code as amended, §124 states that damage means damage to property or the actual loss of property or the rights of the injured party or other damage that is in a causal connection with the crime. Damage also means obtaining a benefit in a causal connection with a criminal offense. Damage also means damage to the profit that the injured party could achieve. It is important for the correct solution to focus on the causal link, which must be proven by the injured party.

### 3. MATERIALS AND METHODOLOGY

By Majdúchová, H. (2012) the determination of lost profit as an economic category is highly specific and I am determined by individual requirements and factors of a particular case. We can only agree with this statement. The determination of lost profits can be divided in terms of areas of legal relations into:

- Determination of loss of profits in criminal matters, where the damage occurs committing the crime
- Determination of lost profits in the field of civil law, breach of obligations between participants in civil law relations,
- Determination of lost profits in the field of commercial law, breach of obligations and contractual relations between participants in commercial legal relations,

- Determination of lost profits in the field of labour law, breach of duty between employee and employer,
- Determination of lost profits in the field of public law, liability of the state for damage caused by public authorities (Majdúchová, H. 2012).

In each of these areas, there may also be a case where the company has ceased operations by bankruptcy or liquidation as a result of a loss event. The amount of financial damage in such a case can be the value of the whole company (Majdúchová, H., Neumanová, A. 2012). The expert has clearly defined methods (property, business, combined, liquidation or comparison), from which he selects and justifies the optimal one (Sedláková, I., Kramárová, K., Vagner, L. 2019). The choice of method will affect in particular the scope and quality of the submitted documents and the phase of the life cycle in which the company was at the time of the occurrence of the loss event (Adámiková, E., Corejova, T., Môcová, L. 2019).

When preparing an expert opinion, the expert works with the documents required from the contracting authority. The contracting authority is responsible for their content and material side, and the expert is responsible for incorporating the documents in the expert evidence. Key documents and information include in particular:

- Description of the activity before the loss event,
- Detailed description of the loss event
- Business plan, resp. development prediction,
- Financial statements as at the date of the valuation, also historically retrospectively,
- Bank statements, treasury books
- Accounting journal for the whole period under investigation
- Contractual relations,
- Calculations, pricing of the services, products in question,
- Accounting and tax documents directly related to the case, etc.

As the expert is criminally liable for his activity, he/she places high demands on the quality and scope of the translated documents. The analysis of documents and work with them is very demanding and its quality creates a platform for further steps of expert evidence (Sedláková, I. 2010). If the documents are not sufficient and of the required quality, the expert may refuse to prepare an expert opinion. In the process of objectification, which should result in an objective value, it incorporates all the essential attributes that take into account the technical and economic nature of the phenomenon under study. A depleted source as a monetary benefit that is achieved from the activities of the company, or from the implementation of the work or project, must be verifiably defined and quantified by an expert. This can be expected in the mutual connection of past development, current state and future development. This connection in expert practice is verified by economic and financial analysis of past development (historical data) in relation to the predicted variables in the business plan. If we consider that the priority is a business plan (prediction of future development) concerning the total activities or partial activities to which the financial loss is related, it is the duty of the expert to examine this, especially in terms of its feasibility. In cases where a business plan has not yet been developed, the priority is valid contractual relations with business partners. If the cause of the loss event is a breach of a specific contractual relationship, then this contract becomes the basic basis. The feasibility of such a contract in terms of both technical and economic parameters is also necessary to examine. It is this phase that is the Achilles heel of expert practice in determining the amount of financial damage. Only after examining the reality of the business plan, resp. development predictions can be made to the calculations themselves (Valaskova, K., Kliestik, T., Kovacova, M. 2019). The reality of the business plan is one of the fundamental professional boundary conditions for the calculation of actual damage and lost profit, financial damage

(Valaskova, K., Kramarova, K., Kollar, B. 2015). The business plan as a determining basis should be attached to the expert opinion, which is often problematic because it is part of the business secret of the company. If, after the analysis, the expert assesses the business plan or contractual relationship, the project as unrealistic, he cannot subsequently calculate the lost profit. We can assume that no harm has occurred.

#### 4. RESULTS AND RECOMMENDATIONS

Based on the analysis of expert opinions as well as our experiences, we defined the marginal conditions of expert evidence in quantifying the damage, lost profits, financial damage to be met regardless of a wide range of possible cases. These boundary conditions represent the procedure, the individual steps of the expert in the process of expert evidence:

- Clear task assignment, naming the event that caused the financial damage
- Determining the decisive date or period when financial loss may have occurred
- Requesting all relevant documents and information
- Characteristics and description of the activity of the company that is damaged
- Analysis of all submitted documents
- Economic and financial analysis of the past development of the company, the current state in relation to its predicted development
- Assessment of the reality of the predicted development in the business plan
- Assessment of causation
- Description of the usual behaviour of the company
- Selection of the optimal method
- Calculation of the amount of financial damage
- Formulation of answers, conclusions and their justification

In expert practice, when quantifying financial loss, it is often possible to quantify the actual damage, but not the lost profit. The occurrence of actual damage does not condition the occurrence of lost profit. As a result of the loss event, there are also increased costs, which the company does not calculate and are not usual for its business activities. These costs must be checked by an expert to determine whether they are in fact additional costs incurred, and to verify their justification, amount and also the accounting aspect. They quantify the extra costs incurred and compare them with the costs usually incurred. Research requires knowledge of calculations, budgeting and pricing in collaboration with technical experts. Technical experts are needed, for example, for the analysis of the technical possibilities of the production process, the technical parameters of the contractual relations, the verification of the production capacities, etc. If the justification and realization of the additional costs are demonstrated, these represent the amount of actual damage from an economic point of view. These can be, for example, the costs of legal services, the elimination of the consequences of a loss event, the costs of economic and accounting services beyond the usual framework, etc. Damage often also occurs to tangible assets such as buildings, machinery, electrical equipment, cars. The determination of the amount of damage to tangible property is not in the competence of economic experts but of technical expert departments. The area of damage to intangible property, such as copyrights, patents, trademarks, know-how (Corejova, T., Al Kassiri, M. 2015), is also interesting. This area is in the competence of industrial property experts (Corejova, T., Corejova, A., Rostasova, M. 2019).

Based on the provision of co-operation to the Ministry of Justice of the Slovak Republic and public authorities in the area of control of expert opinions, it is possible to state the mistakes of experts in determining the amount of financial damage:

- Failure to understand the task and the nature of the damage event
- Insufficient communication with the client of the expert opinion

- Insufficient analysis of submitted documents and information
- Failure to examine the reality of the business plan,
- Work with an insufficient base of documents
- Incorrect method selection
- Insufficient justification of the chosen method
- Insufficient range of annexes to help examine the expert's work
- Failure to define clear parameters when applying the comparison method and other.

These errors can lead to incorrect conclusions, even to an erroneous entire expert opinion. Such an erroneous opinion can be considered by the court as a false expert opinion, which has a direct impact on the activities of the expert. The expert will not be able to carry out his activity because he will be struck off the list and in the worst case he may also be prosecuted and subsequently sentenced to custody. In recent years, two significant cases have been known in the expert practice of the Slovak Republic, where convicted experts were also prosecuted for a false expert opinion in the area of quantification of damage and lost profit. The dispute was between a business entity and the state and it was an error with a significant impact on the state budget.

## **5. CONCLUSION**

When determining the amount of financial damage, there is primarily a penetration of the legal and professional aspects of the problem under investigation. The technical side intersects with the economic side. This captures the essence of the interdisciplinary nature of this issue. We also point out the interdisciplinary nature of expert activity in other topics of expert evidence, with emphasis on the penetration of expert disciplines and the cooperation of experts in various fields. In accordance with the valid legislation of the Slovak Republic, the expert must not solve the legal aspect, but he must understand it correctly in order to choose the optimal method for quantifying the lost profit, damage, and financial damage. The method must be justified, supported by all relevant information and documents. Based on our own research of several cases as well as on the basis of findings from experts in economic experts, it can be stated that the result can be a single value, an interval of values, or an alternative to them. However, after a thorough examination of all documents and information, the expert may come to the conclusion that the value is zero or it is not possible to determine it due to the lack of relevant documents. Such a situation may arise if the event could not have caused a negative economic impact, the relevant economic evidence was not provided, the event prevented a negative economic impact, discontinued the business of a non-profit-making but loss-making business. In some cases, it may detect fraudulent conduct by a business entity that declares it to be an injured party (Sedláková, I. 2017). The diversity of this problem and its complexity place great demands on the expert and require the application of effective tools and methods in accordance with applicable legal standards. A methodologically interesting group consists of loss events in insurance events. In such cases, the expert, even if he finds the optimal method that captures the essence of the loss event, must harmonize it with the insurance contract. The choice of method is limited mainly by the fact of what events the business entity is insured for, what assets the insured has and in what sum insured. Unfortunately, when quantifying lost profits and damages, the problem is that the business entity is supported. This means that he is insured for a lower amount than the market value of his assets and is not insured at all for the loss of clients, which significantly affects the amount of lost profits. The search for optimal methods to quantify the financial as well as non-financial damage of business entities due to the COVID-19 pandemic is also a great challenge. Many businesses had to abruptly stop but also cease their activities. The Government of the Slovak Republic has decided, through specific measures, to at least partially compensate entrepreneurs, employers and also persons in the liberal professions. However, it is already clear that the negative impact of this pandemic is difficult

to quantify. However, we are convinced that the documents defined in this article and the marginal conditions for quantifying financial damage can be fully used.

**ACKNOWLEDGEMENT:** *This contribution was undertaken as a part of the research projects 1/0152/18 VEGA Business models and platforms in the digital environment and 1/0210/19 VEGA Research of innovative attributes of quantitative and qualitative fundamentals of the opportunistic earnings modelling.*

#### LITERATURE:

1. Act no. 382/2004 Coll. about experts, interpreters and translators of The Slovak Republic (2020)
2. Act no. 513/1991 Coll. (2020) The Commercial Code of The Slovak Republic.
3. Act no. 300/2005 Coll. (2020) Penal Code of The Slovak Republic
4. Adámiková, E., Corejova, T., Môcová, L. (2019). Determinants of transport company value and the selection of valuation methods. In: *CBU International Conference Proceedings 2019, Vol. 7: Innovations in Science and Education*, March 20-22, 2019, CBU Research Institute Prague, Czech Republic. - ISSN 1805-997X. ISBN 978-80-907722-0-5. p. 1-7. <http://doi.org/10.12955/cbup.v7.1334>
5. Belas, J., Smrcka, L., Gavurova, B., Dvorsky, J. (2018). The Impact of Social and Economic Factors in the Credit Risk Management of SME. *Technological and Economic Development of Economy*, Volume 24 Issue 3: 1215–1230.
6. Brabenec, T. (2010). Certain important aspects of cost contribution arrangements in
7. financial management. *World Academy of Science, Engineering and Technology*, 43, 921-932.
8. CISG-AC (2006). *Opinion No 6, Calculation of Damages under CISG Article 74*. Rapporteur: Professor John Y. Gotanda, Villanova University School of Law, Villanova, Pennsylvania, USA. Adopted by the CISG-AC at its Spring 2006 meeting in Stockholm, Sweden.
9. Corejova, T., Corejova, A., Rostasova, M. (2019). Innovation ecosystem and intellectual property protection at the university. In: *INTED 2019. The 13th annual International Technology, Education and Development Conference*. ISSN 2340-1079. Valencia: IATED, 2019. - ISBN 978-84-09-08619-1. p. 1189-1198
10. Corejova, T., Al Kassiri, M. (2015). The Power of Knowledge-Intensive Services. In: *4th International Conference on Social Sciences and Society (ICSSS 2015)*, Pt 1 Location: Paris, FRANCE Date: MAY 20-21, 2015, Book Series: *Advances in Education Research*, Vol. 70 P. 354-357 Published: 2015
11. Decree of the Ministry of Justice of the Slovak Republic no. 228/2018, which will implement the Act on Experts, Interpreters and Translators (2018)
12. Decree of the Ministry of Justice of the Slovak Republic no. 492/2004 Coll. on the determination of the general value of assets (2004)
13. Durica, M., Podhorska, I., Durana, P. (2019). Business failure prediction using cart-based model: A case of Slovak companies. *Ekonomicko-manazerske spektrum*, 13(1), 51-61.
14. Hájek P., Zhunisova G., Oralbaeva Z., Zhidebekkyzy A., Baidildina A. (2019). Competitiveness and Economic Profit Analysis of Kazakhstan's Poultry Companies, *Journal of International Studies*, Vol. 12, No 2
15. Kundelis, E., Legenzova, R. (2019). Assessing impact of base erosion and profit shifting on performance of subsidiaries of multinational corporations in Baltic countries. *Equilibrium: quarterly journal of economics and economic policy*. Vol. 14, iss. 2.p. 277-293
16. Majdúchová, H., Neumanová, A. (2012). *Podnik a podnikanie*. SPRINT DVA. ISBN 9788089393831



17. Majdúchová, H. (2012). Stanovenie ušlého zisku v poisťovníctve pre účely znaleckého dokazovania. In: *Zborník vedeckých statí, Prieniky znaleckých odborov v procese znaleckého dokazovania*. Žilina: Žilinská univerzita v Žiline. 121 p. ISBN 978-80-554-0501-8
18. Németh, E., Zsótér, B. (2019). Anxious spenders: Background factors of financial vulnerability, *Economics and Sociology*, Vol. 12, No 2
19. Sedláková, I. (2010). Aktuálne problémy znalca v konaní pre súdy a orgány verejnej moci. In: *Zborník z medzinárodnej odbornej konferencie, Aktuálne problémy ekonomických znaleckých odborov v praxi*. Bratislava. ISBN 978-80-225-3017-0
20. Sedláková, I. (2012a). Prieniky znaleckých odborov pri aplikácii majetkového princípu ohodnotenia podniku. In: *Zborník vedeckých statí, Prieniky znaleckých odborov v procese znaleckého dokazovania*. Žilina: Žilinská univerzita v Žiline. 121 p. ISBN 978-80-554-0501-8
21. Sedláková, I. (2012b). Interdisciplinárny charakter stanovenia výšky finančnej ujmy v procese znaleckého dokazovania. In: *Zborník vedeckých statí, Vybrané problémy znaleckej teórie a praxe v ekonomických znaleckých odboroch*. Žilinská univerzita v Žiline. ISBN 978-80-554-0576-6
22. Sedláková, I. (2017). Hľadanie odpovedí na vybrané otázky znaleckého dokazovania. In: *Zborník vedeckých statí. Aktuálne problémy znaleckého dokazovania. Žilinská univerzita v Žiline, Žilina*. ISBN 978-80-554-1362-4
23. Sedláková, I., Kramárová, K., Vagner, L. (2019) Discussion of theoretical-practical aspects of squeeze out. In: *Littera Scripta*. ISSN 1802-503X. Vol. 12, N. 1 (2019), p. 103-120
24. Siekelova, A., Kollar, B., Weissova, I. (2015). Impact of credit risk management. *Procedia Economics and Finance*, vol. 26, pp. 325-331.
25. Susanto, Y.K., Adrianne, Sh., Pirzada, K. (2019) Is tax aggressiveness an indicator of earnings management?; *Polish Journal of Management Studies*, 20 (2): 516-527;
26. Valaskova, K., Kramarova, K., Kollar, B. (2015). Theoretical Aspects of a model of credit risk determination- Credit risk. *Advances in Education Research*, vol. 81, pp. 401-406.
27. Valaskova, K., Kliestik, T., Kovacova, M. (2019). Assessment of selected models of earnings management in economic conditions of Slovakia. In: *Proceedings of the 33rd International-Business-Information-Management-Association*. Granada, Spain. 10-11th April 2019. pp. 3922-3931.

# MARKETING RESEARCH AS AN ESSENTIAL PREREQUISITE FOR THE SUCCESS OF A MODERN SOCIETY

**Juraj Kolencik**

*University of Zilina, Faculty of Operation and Economics of Transport and Communications,  
Department of Economics, Slovak Republic  
juraj.kolencik@fpedas.uniza.sk*

## **ABSTRACT**

*Marketing research is the mainstay of effective marketing management. Current and high-quality information creates a valuable competitive advantage for the company, capable of participating in the company's growth in the long term. In practice, however, there is often an interpretative confusion of marketing research with market research. This subsequently results in interpretive malformations. These negatively affect the qualification of marketing managers' decisions and create the misconception that marketing research is not important for the company, as its implementation does not see the desired results. The aim of the paper is to identify the main differences between marketing research and market research in the context of the needs of a successful modern society. From a methodological point of view, in addition to the basic methods of formal logic, such as analysis, synthesis, induction and deduction, there are mainly scientific excerpts. This is precisely the main pillar of the realized literary research devoted to the researched issue. Based on it, the output of the article is a basic definition of marketing research and market research as well as a comparison of their basic characteristics in the context of the current needs of a successful modern society.*

**Keywords:** *Marketing research, Marketing management, Market research*

## **1. INTRODUCTION**

For modern service companies, the acquisition and use of relevant information is a necessary condition for their competitiveness and success in a specific, often international, respectively. world market (Krizanova et al, 2019). Marketing research, as an integral part of MIS, provides the information needed for effective marketing management, which aims to achieve set business goals by meeting customer requirements. Marketing research alone would not make sense, without linking to other marketing activities through which the results are realized, but the opposite is also true: without marketing research it is not possible to imagine successful marketing management (Majerova et al., 2020). In view of the above, it can be stated that the success of marketing management and marketing research is mutually conditioned. The company's management must be informed about the target markets in which it realizes its production, about their specifics, it must know its customers, their needs and requirements, the competition, but it must also realistically evaluate the possibilities of its own company, its strengths and weaknesses. The answers to these, as well as many other questions, can be provided by marketing research.

## **2. MARKETING RESEARCH IN THE MARKETING MANAGEMENT PROCESS**

Many domestic and foreign authors consider marketing research to be a service activity whose function is to provide information to marketing management throughout the marketing management process in order to reduce the degree of uncertainty or risk (Gajanova et al., 2019). Marketing research information base for marketing managers in:

- setting marketing goals,
- creation and implementation of marketing plans,
- monitoring the fulfillment of marketing plans (Richterova, 2008).

However, it is necessary to state that despite the above facts, which emphasize the need to carry out marketing research, its role varies from company to company. If marketing research is understood as an information center providing data to assist decision-making and is therefore involved in marketing management processes, in order to reduce uncertainty and risk in decision-making, then according to Kinnear and Taylor we can talk about the system of marketing research. The aim of the information source understood in this way is to reduce the risk and thus the error rate of decision-making by emphasizing the aspects that are taken into account in decision-making, with an emphasis on the growth of its objectivity (Valaskova et al., 2018). Marketing research can be considered as one of the basic information inputs in the decision-making process. The primary task of research is not to make decisions, but only to clarify the decision-making situation. The function of marketing research is to reduce the degree of uncertainty in decision-making (Richterova, 2008).

Just as marketing research is an integral part of MIS, market research is an integral part of marketing research. However, it always focuses on a certain, specific market, represented by certain customers, which it characterizes in more detail through the information obtained. Information does not cover as wide an area as marketing research. If a company wants to be successful in the competition, it must not only know the requirements of its customers, but create a range of goods and services that will reflect them and thus better meet customer demand than the competition. By request we mean a specified need, a specific wish of the customer regarding the goods or services in question. It is similar in the healthcare sector. However, it must be stated that this sector of the economy is significantly distorted by various factors. Getting quality information that fills an information gap and helps solve a problem is not an easy task. The complexity of the implementation of marketing research, as well as the use of specific methods, procedures and research tools requires previous theoretical and practical experience, knowledge and understanding. It should be a pre-planned activity.

In both domestic and foreign professional literature, we can encounter a number of definitions of marketing research. It can be stated that the individual definitions differ from each other depending on the context and the goal that the authors pursue in their works, while the individual definitions are not easy to distinguish exactly from each other. However, with some simplification, it can be noted that these are usually definitions that highlight and characterize marketing research through a sequence of consecutive steps, i.e. through methodology, research process and definition, the essence of which is to focus on achieving predetermined goals, most often obtaining information. The simplest definition of research is offered by the work of John Milton. "Stealing ideas from one person is plagiarism, stealing ideas from a large number of people is research." (Kozel, 2006) Such a view is too simplistic and needs to be expanded with a deeper description to help better understand the issues under study. However, it includes a certain ethical aspect, from which many authors abstract. The definition of Hague (2003) also appears to be very general. Any information needed or otherwise contributing to marketing decisions and the methods used to obtain such data may be considered marketing research. Kotler (2007) defines marketing research through the sequence of individual research steps. Marketing research is the systematic identification, collection, analysis, evaluation of information and conclusions that correspond to a particular marketing situation that the company is facing. A similar approach can be found in the work of McDaniel and Gates (2004), who state that marketing research involves planning, collecting, and analyzing data that is relevant to marketing decisions and communicating the results of that analysis to executives. Again, a certain parallel of consecutive research steps can be observed. Silverman (2003) defines marketing research as the systematic collection, recording, analysis and use of data relating to the transfer and sale of goods and services from the producer to the

consumer. Kita (2002) argues that marketing research specifies the information necessary to concretize marketing problems, designs methods of information collection, manages and implements the process of data collection, analyzes the results and conveys knowledge. It's a feature that connects consumers, customers, and the public to marketers through information. These definitions represent a process view of marketing research, as they emphasize and highlight the sequence of individual steps or phases of research activities. Another view of the issue of marketing research is promoted by Crouch and Housden (2003) According to them, marketing research represents a mechanism for identifying and anticipating customer requirements and for measuring customer satisfaction with product offerings. This approach is largely limited, as it puts the customer in the spotlight and abstracts from other entities that are market participants and which cannot be omitted in the implementation of marketing research (Majerova, 2014). Svobodova (2000) argues that marketing research is a purposeful process that aims to obtain certain specific information that cannot be obtained otherwise. It is a basic prerequisite for applying a marketing approach to the management of a company influenced by a changing marketing environment. Marketing research is an activity that focuses on a comprehensive study of the relationships existing in the market and in the company, examines the effects of external factors on the company, identifies the general laws of the market and analyzes market mechanisms and phenomena that are crucial for the company's existence and survival. It connects consumers, customers and the public with marketers through information (Mesarsova & Mesaros, 2002). Kozel (2006) states that marketing research is a systematic and purposeful process aimed at obtaining certain specific information that cannot be obtained from previous parts of the marketing information system. These definitions, of course with a degree of simplification, are focused and characterize marketing research by focusing on achieving well-defined goals, whether obtaining information or revealing customer requirements. The most comprehensive and, in my opinion, the most accurate definition, which was approved by the International Chamber of Commerce in 2004, can be found on the website of the American Marketing Association. It represents a certain consensus of previous approaches, thus eliminating their shortcomings and highlighting the essence of the problem. Marketing research is a function that connects consumers, customers and the public with marketers through information - information used to identify and define marketing opportunities and problems. Creates, improves and evaluates marketing events. It monitors marketing performance, and improves understanding of the marketing process. Marketing research specifies the information necessary to address these issues, develops methods for collecting information, manages and implements the data collection process, analyzes and presents the results and their implications (Webb, 2002).

### **3. MARKET RESEARCH**

When launching a new service on the market, resp. in the event of any change that could affect customer behavior, marketing managers must have the necessary data on the target market. Marketing managers often encounter the problem of lack of information that would increase their level of knowledge and help eliminate risk. The perception of value by the customer is also a problem, as it is a subjective category that is difficult to determine precisely. What customers value in the present services may not necessarily be based on the past and correspond to the future. When estimating the attributes that create value, managers do not only need common knowledge. They need to collect and analyze a wealth of additional data to help them estimate value perception attributes and identify their clients' requirements in the relevant market. It can be stated very simply that the main goal of market research is to obtain, process and use information about the relevant market, resp. target market segment. As with marketing research, the literature provides a number of definitions of market research, from general to definitions related to a specific problem. Oliveto argues that market research is about listening

to people and analyzing information to help organizations make better decisions and reduce risk (Coll et al., 2004). Parasuraman (1991) considers it a study of customer groups and business competition in order to define the target market. Both definitions are too general and do not fully capture the issue of market research. The ESOMAR representatives argue that market research, which includes social and opinion research, is the systematic collection and interpretation of information on individuals or organizations, using statistical and analytical methods and techniques of applied social sciences to gain insight into or support decision-making (Smith, 2000). Social research and opinion research can be considered market research, but restricting its application to these areas alone would be wrong (Krizanova & Majerova, 2013).

According to Webster's New World College Dictionary, a study of customer requirements or needs for relevant goods and services can be considered market research (Pacakova, 2009). Market research should provide a basic overview of the market and its main factors. In particular, the size, dynamics, structure and other characteristics of the market, competitors and market shares, the composition of distribution channels, economic and other environmental trends. The analysis should answer the framework questions concerning the current and potential demand as well as the company's assumptions to operate successfully in the given market. (Richterova, 2008) Market research should therefore provide an overview of the main factors influencing the relevant market. Bradley (2007) sees market research as a process of systematically collecting, recording and analyzing data and information about customers, competitors, and the market. Its use helps to create a business plan, launch a new product or service, fine-tune existing products or services, and expand into new markets. Pribova (1996) defines market research as “the systematic collection, recording and analysis of data with respect to a particular market, where the market is understood as a specific group of customers in a specific geographical area. Thus, market research can be considered a process of systematic and objectified acquisition, recording, analysis of data and transmission of results on the basic characteristics of the relevant market, customer requirements and needs in the relevant market and the state of competition in the relevant market for better understanding.

#### **4. THE DIFFERENCE BETWEEN MARKET RESEARCH AND MARKETING RESEARCH**

Due to the inconsistency of marketing concepts and poor quality translations of foreign literature, it is often the case in the lay and professional public, as well as in many publications, that the concepts of marketing research and market research are considered identical and interchangeable. Market research and marketing research are now almost identical concepts. In the past, market research has narrowed the area of demand, focusing on examining the sale of products or services and the customer who bought them (Housden, 1992). In the dispute over the concepts of marketing research and market research, most authors maintain an eclectic approach - they use both of these terms as interchangeable. We can add to this problem that both types of research actually take place in a real, specific and limited market and basically use the same methods (Majerova & Kliestik, 2015).

However, if we take a deeper look at the issue, we will find that there is a difference between them. Market research deals in more detail with obtaining information about the market, market potential, market capacity, market segment size or trends, identifies and reveals the requirements and needs of customers in the relevant, specific market, which is further specified and can also solve the competition problem. Marketing research covers a wider range of areas, areas and issues of a particular market, not excluding.

It can be considered a more general, systematic process that can be applied to a wide range of marketing problems. It is not primarily focused on market issues, although similarly to the implementation of market research, the implementation of marketing research must be focused on a specific market, but also on sales, image, price, distribution, advertising and many others. It solves and provides answers to many marketing questions. The subject of marketing research is the marketing system and the factors that influence it. The focus of the research is on the product-defined market and other elements of the marketing organization's microenvironment. The analysis also includes broader contexts related to the influence of macroenvironmental factors (Richterova, 2008). Marketing research is a more complex research task than the market research that is part of it, and for this reason it is not possible to substitute these two concepts. On the other hand, it can be stated that individual procedures, tools and methods of marketing research can be applied to the issue of market research with a certain limitation, which, however, often requires correction. This is also one of the reasons why many authors do not distinguish between the two concepts.

## 5. CONCLUSION

Societal changes such as technical progress, internationalization, informatization, deregulation, globalization and others have led to radical changes in the marketing environment in recent years. Consumers demand higher quality products at lower, or at least the same prices, higher consumer value or individualization of the product. These dynamic societal changes require an ever-increasing pace of updating and innovating specific knowledge. In order for any business entity, regardless of its ownership structure and focus, to succeed in such a rapidly evolving environment, it must have sufficient information about changing market requirements. But their quantity is not primary. Nowadays, it is not a problem to obtain a large amount of data from a variety of information sources. The Internet and other extensive databases provide a wealth of information, but not all of them meet the required level of quality. By criteria of information quality we mean mainly their relevance, validity, reliability, efficiency and timeliness. Get, resp. to select information that meets the previous parameters in order to make a marketing decision is an art and at the same time a necessary condition for the survival and success of all businesses in the market in a competitive environment, regardless of their ownership structure, not only in times and conditions of global economic crisis. Timely and high-quality information is important for both strategic, tactical and operational decision-making, as well as for the control process and activities. Designing quality alternatives for solving specific, original problems, estimating the impacts and consequences of their application and making the right decision is a very demanding process that can take place in different conditions. These differ in the degree of probability of a certain event or trend. The work of marketing managers of service companies in the creation, implementation and control of the company's marketing strategy is basically a decision-making process in conditions of uncertainty or risk. Managers try to thoroughly examine the problem by minimizing the risk and choose the optimal solution to the situation. Understanding the problem correctly, proposing its alternative solutions and making the right decision requires having a sufficient amount of quality information. However, obtaining them is not always easy. One of the solutions to obtain quality information that can provide answers to original questions about the relevant market is market research, as an integral part of marketing research, one of the information sources of a marketing information system.

**ACKNOWLEDGEMENT:** *This contribution is an output of scientific project VEGA no. 1/0718/18: The impact of psychographic aspects of pricing on the marketing strategy of companies across products and markets.*

**LITERATURE:**

1. Bradley, N. (2007). *Marketing research*. Oxford University Press.
2. Coll, E., Olivet, G., Moiguer, F., Mociulsky, M., Kirschbaum, R. (2004). *Shaping high level business decisions through dynamic understanding of consumer insights developing a new graphic media for the new (next) generation*. In: Congress papers 2004 - Integrating Marketing Research in Business, ESOMAR, 2004.
3. Crouch, W., Housden, M. (2003). *Marketing research for managers*. New York: Butterworth-Heinemann.
4. Gajanova, L., Nadanyiova, M., Kliestikova, J., Olah, J. (2019). The potential of using bluetooth-based system as a part of proximity marketing in the Slovak Republic. *Marketing and Management of Innovations*, vol. 2, pp. 239-252.
5. Hague, P. (2003). *Průzkum trhu*. Brno: Computer Press, 2003.
6. Housden, M. (1992). *Successful market research in a week*. London: Holder Stoughton Educational.
7. Kita, J. et al. (2002). *Marketing*. Bratislava: IURA EDITION.
8. Kozel, R. (2006). *Moderní marketingový výzkum*. Praha: Grada Publishing.
9. Kotler, P. (2007). *Marketing management*. Praha: Grada Publishing.
10. Krizanova, A., Majerova, J. (2013). The proposal of activities of pricing policy in the process of building and managing brand value in Slovak Republic. *Advances in Intelligent Systems Research*, vol. 2, pp. 416-419.
11. Krizanova, A., Lazaroiu, G., Gajanova, L., Kliestikova, J., Nadanyiova, M., Moravcikova, D. (2019). The effectiveness of marketing communication and importance of its evaluation in an online environment. *Sustainability*, vol. 11, no. 24, art. no. 7016.
12. Majerova, J. (2014). Analysis of specifics in buying behavior of slovak customers in internet environment. *Advances in Social and Behavioral Sciences*, vol. 5, pp. 172-178.
13. Majerova, J., Kliestik, T. (2015). Brand valuation as an immanent component of brand value building and managing. *Procedia Economics and Finance*, vol. 26, pp. 546-552.
14. Majerova, J., Sroka, W., Krizanova, A., Gajanova, L., Lazaroiu, G., Nadanyiova, M. (2020). Sustainable brand management of alimentary goods. *Sustainability*, vol. 12, no. 2, art. no. 556.
15. Mesarsova, M., Mesaros, F. (2002). *Marketingový výskum*. Bratislava: Ekonóm.
16. McDaniel, C., Gates, R. (2004). *Marketing research: The impact of the internet*. London: Wiley, John and Sons, Inc.
17. Pacakova, V. et al. (2009). *Štatistické metódy pre ekonómov*. Bratislava: Iura Edition, s.r.o.
18. Parasuraman, A. (1991). *Marketing Research*. New York: Addison-Wesley Publishing Company.
19. Pribova, M. et al. (1996). *Marketingový výzkum v praxi*. Praha: Grada Publishing.
20. Richterova, K. (2008). *Marketingový výskum*. Bratislava: EKONÓM.
21. Silverman, D. (2003). *Doing qualitative research, a practical handbook*. London. Sage Publications.
22. Smith, P. (2000). *Moderný marketing*. Praha: Computer Press.
23. Svobodova, H. (2000). *Základy marketingu I*. Ostrava: VŠB-TUO.
24. Valaskova, K., Kliestikova, J., Krizanova, A. (2018). Consumer perceptions of private label products: an empirical study. *Journal of Competitiveness*, vol. 10, no. 3, pp. 149-163.
25. Webb, R. J. (2002). *Understanding and designing marketing research*. London: Thomson.

# **FAMILY FIRMS, CORPORATE GOVERNANCE AND QUALITY OF ACCOUNTING INFORMATION: EVIDENCES FROM LITERATURE**

**Fernando Nascimento Zatta**

*Universidade Presbiteriana Mackenzie, Brazil*  
*zatta@hmzconsulting.com.br*

**Liliane Cristina Segura**

*Universidade Presbiteriana Mackenzie, Brazil*  
*liliane.segura@mackenzie.br*

**Henrique Formigoni**

*Universidade Presbiteriana Mackenzie, Brazil*  
*henrique.formigoni@mackenzie.br*

**Samuel Mamede**

*Universidade Presbiteriana Mackenzie, Brazil*  
*samuel.mamede@mackenzie.br*

## **ABSTRACT**

*This study presents the influence of corporate governance on the quality of accounting information in family businesses and the main governance mechanisms that influence the properties of the quality of accounting information. The bibliometric method was used in order to map the literature and also to disseminate scientific knowledge. The results obtained, supported by the literature, indicates that corporate governance mechanisms positively influence the quality of accounting information in family businesses. The relevant literature presented in this paper provide sources of information to discuss the importance of family businesses and the role of corporate governance on quality of accounting information.*

**Keywords:** *Corporate governance, Family business, Quality of accounting information.*

## **1. INTRODUCTION**

Recent studies such as those by Özçelik (2018), Makhlouf et al. (2013) and Cascino et al. (2010) state that quality accounting information is essential for all companies that compete to acquire resources in the markets. Higher levels of quality of accounting information better reflect the organization's operational performance and make the financial statements more useful in forecasting the company's future performance (Dechow & Schrand, 2004; 2010). In markets characterized by concentration of family ownership, the quality of accounting information is one of the characteristics of corporate governance. One of the results of governance, especially for minority shareholders, is the generation of quality financial reports to promote alignment of interests (Cohen et al., 2004; Jenkins et al., 2009; Burkart et al., 2003; Lakhali, 2015). For disclosure of quality accounting information, there are standards, such as those of the International Accounting Standards Board (IASB, 2008), as well as accounting methods (Bushman et al., 2000; Ball et al., 2000) and metrics for quality measurement accounting information (Barth et al., 2008). Despite the importance of governance mechanisms and disclosure of corporate and financial reports, the level of disclosure of the family business is affected by particular characteristics and complexities such as: management of family presence among instances of power Gersick et al. (1997); succession (Villalonga & Amit, 2004; Wong, 2011); expropriation of minority shareholders (Cascino et al., 2010; Ferramosca and Ghio, 2018), management monitoring (Shleifer and Vishny, 1997); conflict of interest (Berle and Means, 1932); agency costs (Jensen and Meckling, 1976); information asymmetry (Watts and



Zimmerman, 1986; Lakhal, 2015); and quality of accounting (Biddle and Hilary, 2006). Considering these particular issues of the family business, the quality of accounting information would also contribute to the process of assessing market risk, liquidity and interest rate risk, business risk management and price negotiation (Makhlouf et al., 2013), increasing the competitiveness and preserving the family's socio-emotional wealth (Özçelik, 2018; Makhlouf et al., 2013). In turn, investigating the quality of accounting information in the family business is a timely and dominant issue (Burkart et al., 2003), because despite the worldwide importance attributed to the family business (Adigüzel, 2013), very little is known about the quality and informativeness of their accounting reporting practices (Watts and Zimmerman, 1986; Cascino et al., 2010). As far as we are aware, few studies have explored the relationship between corporate governance and the quality of accounting information (Gaio, 2010; Firth et al., 2007). Considering the existing literature, Sloan (2001) already stated that research on this relationship was basically nonexistent. Even today, we are aware that an increasing number of studies have focused on investigating the quality of accounting information influenced by mechanisms other than corporate governance (Morck et al., 1988; Wang, 2006; Chen & Zhang, 2014; Cascino et al., 2010). Furthermore, the integration between corporate governance and quality of accounting information, which are important pillars of reliability and integrity, has received little attention from researchers, making it imperative and relevant to study this integration (Özçelik, 2018; Makhlouf et al., 2013; Nesrine & Abdelwahed, 2010), because in the case of the family business, academic essays have few consistent reflections and difficulty in systematizing recursive issues, such as information quality (Paiva et al., 2008). We focus on these gaps in the literature that motivated this study. As a consequence, the research question that guides this study is: What is the influence of corporate governance on the quality of accounting information in family business? In view of the research question presented, the main objective of this study is to analyze the influence of corporate governance on the quality of accounting information. Most studies that analyzed the influence of corporate governance on the quality of accounting information (Nesrine & Abdelwahed, 2010; Fathi, 2013; Gaio, 2010) provided positive evidence and practical usefulness of this association (Adigüzel, 2013; Wang, 2006). This study is relevant for contributing to the literature of family businesses, regarding the benefits of corporate governance and accounting as a governance mechanism (Bushman et al., 2000; Ball et al., 2000), filling gaps, in a way, little explored (Gersick et al., 1997; Sharma, 2004; Ferramosca and Ghio, 2018). Another relevance is the contribution to a better understanding and dissemination of the metrics of the quality of accounting information, given that in academia there is no consensus on its use (Barth et al., 2008). The study also seeks to contribute with practical applications for regulators and regulators and provides guidance for future research. Finally, the international literature proposes discussions using theoretical methodologies, as in the studies by Gersick et al. (1997), Siebels and Zu Knyphausen-Aufsess (2011). In this study, we adopted the bibliometric method to analyze information and contribute to the dissemination of scientific knowledge (Pilkington and Meredith, 2009). Section 2 presents the theoretical basis, addressing the family business, corporate governance and quality of accounting information. Section 3 deals with the research methodology, Section 4 presents the discussion of the results and Section 5 highlights the conclusion, limitations and suggestions for future research.

## **2. THEORETICAL FRAMEWORK**

The literature points out that family control is widespread among small, medium and large companies listed on the stock exchange or outside the capital market (La Porta et al., 1999). Family-controlled companies represent the predominant and vitally important form of global business (Gersick et al., 1997; Sharma, 2004; Faccio and Lang, 2002; Holderness, 2009; Burkart et al., 2003), forming the basis of capitalist economy (La Porta et al., 1999), even

influencing countries' social, economic and political arenas. The family business has received great attention from researchers. The growth of academic interest has been on the rise since the 1980s, in search of its own identity (Ferramosca and Ghio, 2018; Casillas and Acedo, 2007; Zahra and Sharma, 2004). A growing body of research shows that the family business is significantly different from non-family businesses, solidified in unique characteristics such as concentrated ownership, control and management, long investment horizon, generational successions, performance and participation in social networks (Gómez-Mejía, Cruz & De Castro, 2011). Family involvement in the company results in a set of internal resources that creates idiosyncratic endowments for the business, however, power must be separated from ownership, governance and participation in management (Astrachan et al., 2002). In turn, governance in family businesses, with long-term investment horizons, produces better management monitoring, less information asymmetry, greater alignment of interests between owners and managers (Wang, 2006), better disclosure of earnings to avoid litigation, and reputational costs (Chen and Zhang, 2014), less risk of expropriation of minority shareholders, the elimination of opportunistic actions by owners and managers (Cascino et al., 2010; La Porta et al., 1999; Wang, 2006) and development cooperative relationships to create a sustainable competitive advantage (Sundaramurthy, 2008).

Despite its complexities, the family business still does not have a commonly accepted definition for its understanding, since each organization varies in size, industry and age, among others, as these aspects can significantly impact strategic decision-making processes (Steiger et al., 2015). Among the various definitions, for example, Donnelley (1964) understands that family business is characterized by the existence of at least two generations of a family in power, or according to Chua et al. (1999), controlled by members of the same family or small number of families. Family businesses differ from their unfamiliar peers in terms of several characteristics intrinsic to their own nature, in addition to non-economic objectives, as suggested by the concept of socioemotional wealth. Socio-emotional wealth can be moderated by contingent factors such as family stage, size, risk and presence of non-family shareholders to maintain the company's performance and longevity (Zellweger et al., 2011; Gersick et al., 2006; Chua et al., 1999) and guide successions (Villalonga and Amit, 2004). The particular structure of family ownership involves a diversity of shared roles, such as family members on boards and hiring independent executives for management positions, creating the need for adequate governance structures to maintain business dynamics while avoiding conflicts and agency costs (Siebels and Zu Knyphausen-Aufsess, 2011; Tagiuri and Davis, 1996). Regarding the family business, around the world the literature conditions its definition to ownership and / or to some combinations of components of the involvement of families in the business. Adıgüzel (2013) mentions that there are two dominant theoretical approaches for defining the family business (Siebels and Zu Knyphausen-Aufsess, 2011). The first, consisting of the involvement components approach, points out that the family business is conditioned to the existence of some type of family involvement in property, administration or governance (Chua et al., 1999). The second, the essence approach, explains that family involvement should be directed towards behaviors that separate the family from property and management (Chua et al., 1999).

Other definitions recognize the existence of overlaps between the property and management nuclei - the two-circle model by Tagiuri and Davis (1996) - and in the three-circle model by Gersick et al., (1997) and other researchers who anchor the most current definitions, for example, Astrachan et al. (2002). To understand the dynamics of the family business combined with the diversity of roles that its members share and contribute to conflicts between family and business circles, Gersick et al. (1997) developed the three-circle model that relies on the coexistence of three independent and overlapping systems or axes: property, family and

management and on the interrelationships between them (Villalonga and Amit, 2004) without considering the passage of time. The overlap between family and business must be balanced to maintain business development and family purposes (Stafford et al., 1999). Interrelationships between and within the family are organized and monitored by family governance (Bonaccorsi, 2016), alleviating agency problems (Jensen and Meckling, 1976). Due to the global view on the importance of family businesses, over the years a set of corporate initiatives has emerged around corporate governance that potentially generates the quality of corporate and accounting information for these companies to maintain their longevity (Bushman et al., 2000; Firth et al., 2007; Klai e Omri, 2010). International research seeks to understand the way in which corporate governance in each country helps to solve problems in the corporate world and financial disclosure (Aguilera and Cazorra, 2009). In this context, La Porta et al. (2000) explain that corporate governance has mechanisms to monitor and protect investors against expropriation of invested capital, improve the quality of disclosure to monitor the company's performance, preserve organizational resources, balance the exercise of power and limit agency conflicts (Cadbury, 1992; Jensen and Meckling, 1976).

Governance is of enormous practical importance, positively influences the quality and usefulness of accounting information and helps to create a sustainable organizational environment (Wang, 2006; Jenkins et al., 2009; Schleifer and Vishny, 1997). The main characteristic of corporate governance in family businesses, which distinguishes it from non-family businesses, is the diversity of roles that family members share (Steiger et al., 2015; Tagiuri and Davis, 1996). As for business content, the family business differs significantly from non-family businesses in dimensions such as agency costs, competitive advantages or corporate governance structure, according to three predominant theoretical perspectives: principal-agent theory, management theory and the vision based in firm resources (Siebels and Zu Knyphausen-Aufsess, 2011). The characteristic of family participation in the company, on the other hand, consists of the need for family governance. According to Donnelley (1964) the systemic approach positions that family business governance is composed of two interaction subsystems (Gallo et al., 2005): corporate and family governance (Aronoff and Ward, 1996). Thus, unlike the management and control exercised by the management team, board of directors and shareholders' meeting, the family governance subsystem monitors and organizes family cohesion (Gallo et al., 2005; Gersick et al., 1997; Mustakallio et al., 2002) and consists of a family council and general shareholders' meeting (Gallo et al., 2005).

On the management side, the board of directors is one of the most important elements of corporate governance to align the interests of managers and shareholders, especially in family businesses (Wellalage and Scrimgeour, 2012). Still on the management side, the importance of the conflict of interest monitoring mechanism (Berle and Means, 1932) and the consequent reduction of agency problems such as changes in the controlling block, delisting, dispute between shareholders, expropriation are emphasized minority shareholders' rights and dubious transactions with related parties (Jensen and Meckling, 1976; Chen and Zhang, 2014). The board of directors, and especially the audit committee, control agency problems through the quality of the accounting information reported to the various agents, shareholders and investors (Pascual-Fuster and Cladera, 2018). The separation of ownership and control results in the Type I agency problem and the conflict of interest between insiders and non-controlling external investors results in the Type II agency problem. Sound governance advice can reduce the Type I agency problem and can also mitigate the adverse consequences of the Type II agency problem before they materialize, avoiding the entrenchment effect (Morck et al., 1988). Consequently, the Type II agency problem in family businesses leads investors to demand more high-quality accounting information and greater disclosure transparency (Ali et al., 2007).

Reducing information asymmetry is another important mechanism linked to the quality and increasing the usefulness of accounting information (Jensen and Meckling, 1976; Lakhal, 2015; Biddle and Hilary, 2006), as it acts as an effective control device for minority shareholders (Shleifer and Vishny, 1997). According to Özçelik (2018), effective accounting information is, worldwide, an important governance mechanism. According to Makhoul et al. (2013), the quality of accounting information is the most important mechanism that can be used to measure market risk, liquidity risk, interest rate, business risk management and price negotiation. The existing literature has extensively documented that higher quality of accounting information is associated with stronger corporate governance mechanisms (Wang, 2006). According to Giroud and Mueller (2011), accounting information is relevant when it is associated with mechanisms of good corporate governance practices, not least because the quality of information is one of the main functions of governance (Cohen et al., 2004). The quality of accounting information has been investigated by several studies in developed and emerging countries over the past forty years. Its importance gained importance in the 1990s, mainly in the United States, based on the quality of annual corporate reports for decision making by market analysts (Beaver, 1981).

Since the study by Ball and Brown (1968), the informational content of financial statements has remained a highly demanded area of research. According to Kothari (2000) the quality of financial reports directly affects the market in general: companies under family, non-family, state control or financial conglomerates (Ball and Shivakumar, 2005). According to Makhoul et al. (2013), the accounting literature has not yet provided a conceptual definition of the quality of accounting information that is consensual in the academic environment. Quality is defined as the ability of accounting measures to reflect the company's economic position and performance for decision making (Verleun et al., 2011). For Dechow et al. (2010) the quality of accounting information is a faithful representation of a company's financial performance characteristics that are relevant to a specific decision by a specific decision maker and that only makes sense with the specification of the decision context. Sloan (2001) indicates that research on the quality of information has been little studied, with researchers analyzing only the role of information at the macro level, using measures of quality of the accounting system, which requires more comprehensive research with the operational definition of the variables.

In this regard, Isidro and Raonic (2012) report that the quality of accounting information is difficult to observe and measure, whereas Yoon (2007) understands that there is still no predominant and generally accepted agreement to verify it directly, since they are constructs operationalized through proxies (Ecker et al., 2013). Gu and Li (2016) report that it is difficult to find a substantially consistent financial indicator to assess the quality of accounting information, which in practice is complex, because on the one hand, the degree of quality is abstract and difficult to measure, on the other hand, there are many users with different expectations. Dechow and Schrand (2004) state that the quality of accounting information must accurately reflect current performance to predict the company's future performance.

Although it is discussed in academia that there is still no consensus on metrics to measure the quality of accounting information, most studies, such as, for example, Barth et al. (2008) and Moura et al. (2015), uses four properties: (i) timeliness in book values (timeliness) (Basu, 1997; Ball et al., 2000); (ii) earnings management (Shleifer and Vishny, 1997; Leuz, 2003; Dechow and Schrand, 2004); (iii) conditional conservatism (Basu, 1997; Leuz, 2003); and (iv) relevance of accounting information (value relevance) (Ball and Brown, 1968; Beaver, 1968; Ohlson, 1995; Wang, 2006).

Based on the above, research has revealed that the quality of accounting information is classified, more precisely, into four main properties: (i) timing; (ii) earnings management; (iii) conservatism; and (iv) relevance. Other research revealed other properties such as: transparency, disclosure level, share price, market value of the company (Dechow et al., 2010; Paulo et al., 2012).

### 3. METHODOLOGY

In order to present the development of research in the main international journals and to understand the state of the art about the themes of the study, we applied bibliometrics (Pilkington and Meredith, 2009), quantitative and statistical technique for measuring indexes and identifying important aspects of scientific production (Jonkers and Derrick, 2012) for the dissemination of knowledge (Tahai and Meyer, 1999). As for the objectives, this is descriptive research (Vergara, 2014). The researchers acted in the identification of the databases, in the choice of the sample and in the treatment and analysis of the information (Richardson, 2015). Descriptive, as this is a research that identified, analyzed and described the characteristics of scientific production on the themes of corporate governance and the quality of accounting information in family businesses. As for technical procedures, the study reviewed and adopted procedures for surveying and mapping scientific production in the relevant literature, in order to meet its main objective (Cândido et al., 2016).

We adopted a non-probabilistic, intentional and rationally selected sample (Richardson, 2015) by judgment (Costa-Neto, 1977), in which supported by experience we chose the most representative constituent elements of the sample. The bibliometric analysis developed followed the steps of Zupic and Carter (2015). The collection of journals was generated using the keywords: Family business, corporate governance and quality of accounting information or quality of financial information, in the following databases: CAPES, Google Scholar, Web of Science, Science Direct, Mendeley, Elsevier, Scopus, EBSCO, SPELL, JSTOR. In addition to the bases, we highlight some highly reputable journals, following some steps of the data collection protocol (Fahimnia et al., 2015): Journal of Accounting Research, Journal of Financial Economics, Family Business Review, Strategic Management Journal, Organization Science, The American Economic Review Journal of Accounting Research, Journal of Accounting and Economics, Journal of Financial Economics, The Journal of Finance, Accounting and Finance Research, International Business Research, Journal of Management & Organization, European Financial Management, Australasian Accounting Business and Finance Journal, African Journal Accounting, Auditing and Finance, China Journal of Accounting Research, Malaysian Accounting Review, RAE - Revista de Administração de Empresas, Revista de Contabilidade & Finanças – USP, RAM - Revista de Administração Mackenzie.

Using the selected search terms, together with the application of the articles and keywords filter, a preliminary gross database of 554 journals in digital format was created. Then, a series of sample filter steps was performed to form the article portfolio and conclude with the prioritization of the convergent database. When analyzing the articles, a new filtering was done by eliminating the articles whose keywords were not aligned with the objective of the study, which were kept. These data were archived in PDF and Word® format, then transported to an Excel® spreadsheet. Finally, the last, more selective filtering was carried out by reading the abstracts and texts of the articles. At the end of this process, it was possible to form the final portfolio that includes 333 articles.

The description metadata, such as title, abstract, keywords, authors, year of publication, country, among other data, were grouped in several cells of the Excel® spreadsheet, giving rise to tables, tables and graphs, for the analysis of qualitative data and quantitative, which were dealt with using the content analysis methodology (Richardson, 2015). In addition to the fields mentioned above, 13 columns were added to insert themes related to family businesses, 19 columns related to corporate governance mechanisms, and 14 columns related to the quality of accounting information.

#### 4. DISCUSSION

The results obtained by the investigation ensured that the articles aligned with the study's themes met quality criteria, presented by the academic society, for consultations and deepening of specific topics (Treinta et al., 2014). This section presents and discusses the results obtained with the descriptive analysis of data from current research on family businesses, corporate governance and quality of accounting information. The scientific production in family business presented several themes. The most expressive themes addressed in the articles that deserve to be highlighted were: socio-emotional wealth (38 articles, 15.4% of the total), succession (29 articles, 11.7% of the total), business life cycle (21 articles, 8.5 % of the total), longevity (18 articles, 7.3% of the total), cultural dimensions and management style (17 articles, 6.9% of the total), family control and management (12 articles, 4.9% of the total). It should be considered that, worldwide, the family business is strongly characterized by the presence of the family sharing a diversity of roles, in addition to highly concentrated ownership and management (Steiger et al., 2015; Tagiuri and Davis, 1996) that require governance mechanisms corporate (Mustakallio et al., 2002).

The mechanisms regarding governance principles (89 articles, 36.0% of the total), agency conflict (78 articles, 31.5% of the total), external executives (70 articles, 28.3% of the total), deserve to be highlighted. governance practices (68 articles, 27.3% of the total), corporate social responsibility (59 articles, 23.9% of the total), professional management, non-family CEO (56 articles, 22.7% of the total), board administration (42 articles, 16.6% of the total), institutional environment (40 articles, 16.2% of the total), monitoring and control (37 articles, 15.0% of the total), size of the board (37 articles, 15.0% of the total), incentives and benefits (31 articles, 12.5% of the total), voluntary disclosure (26 articles, 10.5% of the total), family governance (26 articles, 10.5% of the total), political connections (23 articles, 9.3% of the total), external audit (19 articles, 7.7% of the total), and audit committee (7 articles, 2.8% of the total).

The results show development and expansion of research efforts to ensure family cohesion and investor protection. In this way, governance in the family business would achieve a balance between family, property and management, ensuring monitoring, equity, transparency and information disclosure (Wong, 2011).

It should also be considered that other studies have explored the quality of accounting information through other properties such as transparency, level of disclosure, share price, opinion of financial analysts, market value of the company (Dechow et al., 2010; Isidro and Raonic, 2012), among others. We emphasize that most of the articles analyzed are of a theoretical-empirical nature (78.3%), followed by theoretical articles (21.7%), such as the work by Paiva et al. (2008). In the period between 1990 and 2018, scientific production on the themes of the study grew, reaching its peak in 2018, with seventy publications. The acceleration occurred from 2010, closing in nine publications, being that in each year in the period from 1990 to 2009, the number of publications did not exceed six.

This fact can be explained by the reviews by Zahra and Sharma (2004), Sharma (2004) and Casillas and Acedo (2007) about the development of the research frontier in the family business. It was in 1989 that studies entered a new period of scientific normality (Casillas and Acedo, 2007). We analysed also thirteen journals with the largest number of publications. Main highlight for the Family Business Review - FBR (48 articles, 19.4% of the total), followed by the Journal of Family Business Strategy - JFBS (28 articles, 11.3% of the total), and the Corporate Governance An International Review ( 10 articles, 4.0% of the total). The FBR is the only journal that deals specifically with family businesses present in the Web of Science database. The JFBS is present in the Elsevier database, publishes research in the business field on issues related to the influence of the family on business and the influence of business on the family. The distribution of selected journals shows that the Management area (180 articles, 72.9%) leads the publications, followed by Accounting (23 articles, 9.3%), Multidisciplinary (30 articles, 12.1%) and Business (14 articles, 5.7%).

The quotations on the study themes come from international journals. It is also worth mentioning the most fruitful authors: Alessandro Minichilli, Silvia Ferramentasosca and Alessandro Ghio, both from Italy, which shows alignment with the country that publishes the most, followed by Danny Miller (USA) and Isabelle Le Braton-Miller ( Canada), in the case of authors who research in co-authorship. The continent with the largest number of publications is Europe (357 articles, 45.8% of the total), followed by Asia (235 articles, 30.1% of the total), South America (69 articles , 8.8% of the total), North America (43 articles, 5.5% of the total), Central America (38 articles, 4.9% of the total), Africa (26 articles, 3.3% of the total) and Oceania (12 articles, 1.5% of the total). Na América do Sul, o Brasil é o país com maior número de publicação (29 artigos, 29,0% do total) seguido do Chile (9 artigos, 13,0% do total), Argentina (8 artigos, 11,6% do total) e Colombia (7 artigos, 10,1% do total). Regarding the number of publications, the leadership is from Italy (41 articles, 5.3% of the total), followed by Malaysia (27 articles, 3.5% of the total), the United States and Spain (both with 26 articles, 3.3% of the total), Brazil and Taiwan (both with 20 articles, 2.4% of the total) forming the bloc of the five countries with the largest number of publications.

## 5. CONCLUSION

This study investigated the influence of corporate governance on the quality of accounting information in family businesses using the bibliometric method for analyzing information, covering articles published in ten databases and international journals. The results, supported by the literature, revealed the importance of family businesses in the economy supporting global businesses and the importance of corporate governance and accounting information to ensure the longevity of these organizations. The results show the importance of the association of corporate governance with the quality of accounting information in the field of family businesses, as can be inferred from the high repetition of citations that points to the existence of consensus on what are the prevailing conceptual foundations and whose scientific rigor of investigations points to the consolidation of this field. Corporate governance was identified as a structure that provides mechanisms for preserving resources and limiting conflicts in the three circles suggested by Gersick et al. (1997): family, property and management and positively influence the quality and usefulness of accounting information (Wang, 2006; Jenkins et al., 2009). The quality properties of accounting information most present in the analyzed studies follow the informativeness approach, as suggested by Barth et al. (2008) and Moura et al. (2015), timeliness, conservatism, earnings management and relevance of accounting information. It was observed that most articles adopted methodologies of a theoretical-empirical nature, followed by theoretical articles, with authors researching in co-authorship.

It was also possible to identify that the production on the themes grew with greater intensity in the period from 2009 to 2018, probably due to the growing importance of family businesses worldwide. The result demonstrates that Europeans and Asians add up to more than 70% of all scientific production on the themes, while Brazil contributes with 2.4%, comparing to Taiwan, and the leading country in Latin America. The most recent works gained prominence in new research, but without losing sight of the seminals. Despite the objectivity of the applied methodology, our study has some limitations, among which the selection of databases and journals that, despite their breadth, may not have considered other works in other databases. Finally, this study provides important suggestions for future research. To seek understanding as to whether accounting influences corporate governance or if it would be the other way around, given the strong link that exists simultaneously between accounting and governance. Deepen conceptual studies to develop a definition of “quality”, for the quality of accounting information. Identify whether the four properties of the quality of accounting information reflect the economic reality of companies and influence decision making. Analyze in the context of family businesses, among the four properties, which would be the best proxy in relation to the quality of accounting information. Identify the factors that determine the quality of corporate governance mechanisms for managing the company. Assess which mechanisms of corporate governance and accounting policies influence the characteristics of accounting information of Brazilian companies. Investigate why theoretical works on family businesses have few consistent reflections and difficulty to be published. This study provides a broad view of research on the topics investigated and, in general, contributes to the increase in the literature on topics within family businesses and, to assist the work of academics, students, consultants, entrepreneurs and managers in command of family business.

#### **LITERATURE:**

1. Adıgüzel, Hümeyra. (2013). Corporate Governance, Family Ownership and Earnings Management: Emerging Market Evidence. *Accounting and Finance Research*. 2. 17-33. 10.5430/afr.v2n4p17.
2. AGUILERA, R. V.; CAZURRA, A. C. Codes of Good Governance. *Corporate Governance: An International Review*, v. 17, n. 3, p. 1-13, may. 2009.
3. Al-Shammari, Bader & Al-Sultan, Waleed. (2010). Corporate governance and voluntary disclosure in Kuwait. *International Journal of Disclosure and Governance*. 7. 262-280. 10.1057/jdg.2010.3.
4. Ali, A., Chen, T-Y., & Radhakrishnan, S. (2007). Corporate disclosures by family firms. *Journal of Accounting and Economics*, 44, 238-286.
5. Aronoff, C. and Ward, J. (1996). *Family Business Governance: Maximizing Family and Business Potential*, 3rd edn. Marietta, GA: Family Business Publishers.
6. Astrachan, J. H., Klein, S. B., & Smyrnios, K. X. (2002). The F-PEC scale of family influence: A proposal for solving the family business definition problem. *Family Business Review*, 15(1), 45-58. doi:10.1111/j.1741- 6248.2002.00045.x
7. Ball, R. e Shivakumar, L. (2005). Earnings quality UK private firms: comparative loss recognition timeliness. *Journal of Accounting and Economics* 39 (1): 83-128.
8. Ball, R. J. And Brown, W..(1968). An empirical evaluation of accounting income. numbers. *Journal of Accounting Research*, Vol. 6, p.159-178, Autumn 1968.
9. Ball, R., S.P. Kothari, and A. Robin. (2000). The Effect of International Institutional Factors on Properties of Accounting Earnings. *Journal of Accounting and Economics* 29: 1-51.
10. Bao, S. R., & Lewellyn, K. B. (2017). Ownership structure and earnings management in emerging markets - An institutionalized agency perspective. *International Business Review*.
11. Barth, M.E., Landsman, W.R., Lang, M., (2008). International accounting standards and accounting quality. *Journal of Accounting Research* 46, 467–498.



12. Basu, S., 1997, The conservatism principle and the asymmetric timeliness of earnings, *Journal of Accounting & Economics* 24, 3-37
13. BEAVER, William H. The Information Content of Annual Earnings Announcements. *Journal of Accounting Research* v. 6, p. 67–92, 1968.
14. Beaver, William. (1981) Financial reporting: An accounting revolution. *Journal of Accounting and Economics* (3) 243-252.
15. Berle, A.; Means, G. *The Modern Corporation and Private Property*. New York: Macmillan, 1932.
16. Biddle G, Hilary G. 2006. Accounting quality and firm-level capital investment. *The Accounting Review* 81(5): 963–982.
17. Bonaccorsi, Matheus F. *Governança Jurídica nas Empresas Familiares*. 1. ed. Belo Horizonte: Editora Del Rey, 2016. v. 1.
18. Burkart, Mike; Panunzi, Fausto; Shleifer Andrei. (2003) Family Firms. *The Journal of Finance* v. 58, n. 5, p. 2167–2201, 1 out.
19. Bushman, R.; Chen, Q.; Engel, E.; Smith, A. (2000). The sensitivity of corporate governance systems to the timeliness of accounting earnings. Working Paper. Chapel Hill, University of North Carolina, 63 p.
20. Cadbury, A. (1992) Report of the Committee on the Financial Aspects of Corporate Governance, London, Gee Publishing.
21. Cândido, Ricardo Batista; Tambosi Filho, Elmo; Kuniyoshi, Márcio Shoití. (2016) Os Principais trabalhos sobre capm condicional no web of science: uma análise de citações e cocitações entre 2000-2014. *Revista de Administração da UEG (RAUEG)*, v. 7, n. 2, p.114-128, 2016.
22. Cascino, Stefano & Pugliese, Amedeo & Mussolino, Donata & Sansone, Chiara. (2010). The Influence of Family Ownership on the Quality of Accounting Information. *Family Business Review*. 23. 10.1177/0894486510374302.
23. Casillas, J. C., & Acedo, F. (2007). Evolution of the intellectual structure of family business literature: a bibliometric study of FBR. *Family Business Review*, 20(2), 141-162.
24. Chen, J. J., & Zhang, H. (2014). The impact of the corporate governance code on earnings management– Evidence from Chinese listed companies. *European Financial Management*, 20(3), 596–632.
25. Chua, J.H., Chrisman, J.J., & Sharma, P. (1999). Defining the family business by behavior. *Entrepreneurship Theory and Practice*, 23, 19–39.
26. Cohen J, Krishnamoorthy G and Wright A (2004), “The Corporate Governance Mosaic and Financial Reporting Quality”, *Journal of Accounting Literature*, Vol. 23, pp. 87-152.
27. Costa-Neto, P. L. *DE O. Estatística*. 1. ed. São Paulo: Edgard Blücher, 1977.
28. Dechow, P., W. Ge; Schrand, C. M. (2010). Understanding earnings quality: a review of the proxies, their determinants and their consequences. *Journal of Accounting and Economics* 50(2–3): 344–401.
29. Dechow, P.M. and Schrand, C.M. (2004) *Earnings Quality*, CFA Institute, Charlottesville, Virginia.
30. Donnelley, R.G. (1964) The family business. *Havard Business Review*, v.42, n.4, pp.93-105.
31. Ecker, F. et al. Estimation sample selection for discretionary accruals models. *Journal of Accounting and Economics*, v. 56, p. 190-211, 2013.
32. Faccio, M. and Lang, L.H.P. (2002) The Ultimate Shareholdership of Western European Corporations. *Journal of Financial Economics*, 65, 365-395. [http://dx.doi.org/10.1016/S0304-405X\(02\)00146-0](http://dx.doi.org/10.1016/S0304-405X(02)00146-0)

33. Fahimnia, B.; Sarkis, J.; Davarzani, H. Green supply chain management: a review and bibliometric analysis. *International Journal of Production Economics*, v.162, pp.101-114, 2015
34. Fathi, J. (2013). The determinants of the quality of financial information disclosed by French listed companies. *Mediterranean Journal of Social Sciences*, 4(2), p. 319-336. DOI: <https://doi.org/10.5901/mjss.2013.v4n2p319>
35. Ferramosca, Silvia, Ghio, Alessandro (2018). *Accounting Choices in Family Firms An Analysis of Influences and Implications*. <http://www.springer.com/series/1505>.
36. Firth, M., Fung, P. & Rui, O. (2007). Ownership, two-tier Board Structure, and the Informativeness of Earnings: Evidence from China. *Journal of Accounting and Public Policy*, 26, (4), 463-496.
37. Gaio, C. (2010). The relative importance of firm and country characteristics for earnings quality round the world. *European Accounting Review*, 19(4), pp. 693-738. DOI: <http://dx.doi.org/10.1080/09638180903384643>.
38. Gallo, M. and Kenyon-Rouvinez, D. (2005). The importance of family and business governance. In Kenyon-Rouvinez, D. and Ward, J.L. (eds), *Family Business. Key Issues*. Basingstoke: Palgrave/Macmillan, pp. 45–57.
39. García, M. D. P. R., Alejandro, K. A. C., Sáenz, A. B. M., & Sánchez, H. H. G. (2016). Does an IFRS adoption increase value relevance and earnings timeliness in Latin America? *Emerging Markets Review*.
40. Gersick, K.; Davis, J.; Hampton, M.; Lansberg, I. (1997) *De geração para geração: Ciclo de vida da empresa familiar*. 2ed. São Paulo: Negócio, p. 308.
41. Gersick, K. E.; Davis, J. A.; Hampton, M.; Lansberg, I. (2006) *De geração para geração: ciclos de vida das empresas familiares*. 1. ed. Rio de Janeiro: Editora Elsevier, 2006.
42. Giroud, X., and Mueller, H. M.. “Corporate Governance, Product Market Competition, and Equity Prices.” *Journal of Finance*, 66 (2011), 563–600
43. Gómez-Mejía, L. R., Cruz, C., Berrone, P. , & De Castro, J. (2011). The bindthat ties: Socioemotional wealth preservation in family firms. *The Academy of Management Annals*, 5(1), 653–707.
44. Gonzalez, J. S., & Garcia-Meca, E. (2014). Does corporate governance influence earnings management in Latin American markets? *Journal of Business Ethics*, 121(3), 419–440.
45. González, Jesus & García-Meca, Emma. (2014). Does Corporate Governance Influence Earnings Management in Latin American Markets?. *Journal of Business Ethics*. 121. 10.1007/s10551-013-1700-8.
46. Gu X., Li X. (2016). How to improve the quality of accounting information based on the corporate governance, *M&D Forum*, 201-208.
47. Habbash, M., Xiao, L., Salama, A., & Dixon, R. (2014). Are independent directors and supervisory directors effective in constraining earnings management? *Journal of Finance, Accounting and Management*, 5(1), 125-160.
48. Holderness, Clifford G. (2009) *The Myth of Diffuse Ownership in the United States*. *The Review of Financial Studies* v. 22, n. 4, p. 1377–1408.
49. IASB – IFRS Foundation and International Accounting Standards Board. *Due process handbook for the IASB*. Acesso em: 03 set. 2012, 2018.
50. Isidro, H., & Raonic, I. (2012). Firm incentives, institutional complexity and the quality of “harmonized” accounting numbers. *The International Journal of Accounting*, 47(4), pp. 407-436. DOI: <https://doi.org/10.1016/j.intacc.2012.10.007>
51. Jenkins, David S.; Kane, Gregory D.; Velury, Uma (2009). Earnings Conservatism and Value Relevance Across the Business Cycle. *Journal of Business Finance & Accounting* v. 36, n. 9–10, p. 1041–1058 , 1 nov.

52. Jensen, M.; Meckling, W. (1976) Theory of the firm: managerial behavior, agency costs and ownership structure. *Journal of Financial Economics*, v. 3, n. 4, p. 305-360.
53. Jonkers, K; Derrick, G. The bibliometric bandwagon: Characteristics of bibliometric articles outside the field literature. *Journal of the American Society for Information Science and Technology*, 2012. v. 63(4); p. 829–836.
54. Kothari S. P.. The role of financial reporting in reducing financial risks in the market. *Conference Series ; [Proceedings]*, 2000, vol. 44, issue Jun, 89-112
55. La Porta, R.; López-De-Silanes, F.; Shleifer, A.; Vishny, R. 2000. Investor protection and corporate governance. *Journal of Finance*, 58:3-27.
56. La Porta, Rafael; Lopez-De-Silanes, Florencio; Shleifer, Andrei. (1999) Corporate Ownership Around the World. *The Journal of Finance* v. 54, n. 2, p. 471–517.
57. Lakhal, Nadia. (2015). Corporate Disclosure, Ownership Structure And Earnings Management: The Case Of French-Listed Firms. *Journal of Applied Business Research*. 31. 1493-1504. 10.19030/jabr.v31i4.9332.
58. Leuz, C. 2003. IAS Versus U.S. GAAP: Information Asymmetry-based Evidence from Germany's New Market. *Journal of Accounting Research* 41: 445-427.
59. Makhlof, Mohammed. (2013). Corporate Governance and Its Impact on the Quality of Accounting Information in the Industrial Community Shareholding Companies Listed in Amman Financial Market- Jordan.. *International Journal of Humanities and Social Science*. 3. 184-195.
60. Morck, Randall K. Shleifer, Andrei; Vishny, Robert W. (1988) Management Ownership and Market Valuation: An Empirical Analysis *Journal of Financial Economics*, Vol. 20, p. 293-315 Available at SSRN: <https://ssrn.com/abstract=1506393>
61. Moura, Geovanne, & Franz, Leandro & Cunha, Paulo. (2015). Qualidade da informação contábil em empresas familiares: influência dos níveis diferenciados de governança da BM&FBovespa, tamanho e independência do conselho de administração. *Contaduría y Administración*. 129. 10.1016/S0186-1042(15)30008-5.
62. Mustakallio, M., Autio, E. and Zahra, S.A. (2002). Relational and contractual governance in family firms: effects on strategic decision making. *Family Business Review*, 15, pp. 205–222.
63. Nesrine, Klai & Abdelwahed, Omri. (2010). Corporate Governance and Financial Reporting Quality: The Case of The Tunisian Firms. *International Business Research*. 4. 10.5539/ibr.v4n1p158.
64. Ohlson, James A (1995), Earnings, book values, and dividends in equity valuation, *Contemporary Accounting Research*, Vol. 11, No. 2, pp 661-687.
65. Özçelik, Hakan. (2018). Kurumsal Yönetim Temelinde Muhasebe Bilgi Kalitesinin Geliştirilmesi. *Muhasebe ve Vergi Uygulamaları Dergisi*. 2018. 485-507. 10.29067/muvu.341191.
66. Paiva, K. C. M.; Oliveira, M. C. S. M.; Melo, M. C. O. L. (2008) Produção científica brasileira sobre empresa familiar: um meta estudo de artigos publicados em anais de eventos da ANPAD no período de 1997-2007. *Revista de Administração Mackenzie*, São Paulo, v. 9, n. 6, p. 148-173, set./out.
67. Pascual-Fuster, Bartolomé & Cladera, Rafel. (2018). Politicians in the boardroom: Is it a convenient burden?. *Corporate Governance: An International Review*. 10.1111/corg.12261.
68. Paulo, E.; Cavalcante, P. R. N.; Melo, I. I. S. L. DE. Accounting information quality in public stock and bond offerings by brazilian public companies. *Brazilian Business Review*, v. 9, n. 1, p. 1 – 26, 30 mar. 2012.
69. Pilkington, A., & Meredith, J. (2009). The evolution of the intellectual structure of operations management—1980–2006: A citation/co-citation analysis. *Journal of Operations Management*, 27(3), 185–202. doi:10.1016/j.jom.2008.08.001

70. Richardson, R. J. *Pesquisa Social: Métodos e Técnicas*. 3. ed. São Paulo: Atlas, 2015.
71. Sharma, P. (2004). An Overview of the Field of Family Business Studies: Current Status and Directions for the Future. *Family Business Review*, 17(1), 1–36. <https://doi.org/10.1111/j.1741-6248.2004.00001.x>
72. Shleifer, Andrei, and Robert W Vishny. 1997. “A Survey of Corporate Governance.” *Journal of Finance* 52 (2): 737-783.
73. Shleifer, Andrei; Vishny, Robert W. (1997) A survey of Corporate Governance. *The Journal of Finance*, v. 52, n. 2, p. 737-783.
74. Siebels, Jan-Folke & Zu Knyphausen-Aufsess, Dodo. (2011). A Review of Theory in Family Business Research: The Implications for Corporate Governance. *International Journal of Management Reviews*. 14. 10.1111/j.1468-2370.2011.00317.x.
75. Silva, R. L. M. (2013). *Adoção completa das IFRS no Brasil: Qualidade das demonstrações contábeis e o custo de capital próprio* (Tese de Doutorado em Ciências Contábeis, Departamento de Contabilidade e Atuária da Faculdade de Economia, Administração e Contabilidade, Universidade de São Paulo).
76. Sloan, R.G. (2001). Financial accounting and corporate governance: A discussion. *Journal of Accounting and Economics*, 32(1-3):335-347.
77. Stafford, K., Duncan, K. A., Dane, S., & Winter, M. (1999). A Research Model of Sustainable Family Businesses. *Family Business Review*, 12(3), 197–208. <https://doi.org/10.1111/j.1741-6248.1999.00197.x>
78. Steiger, Tanja & Duller, Christine & Hiebl, Martin. (2015). No Consensus in Sight: An Analysis of Ten Years of Family Business Definitions in Empirical Research Studies. *Journal of Enterprising Culture*. 23. 25-62. 10.1142/S0218495815500028.
79. Sundaramurthy, C. (2008). Sustaining Trust Within Family Businesses. *Family Business Review*, 21(1), 89–102. <https://doi.org/10.1111/j.1741-6248.2007.00110.x>
80. Tagiuri, R. and Davis, J. (1996). Bivalent attributes of the family firm. *Family Business Review*, 9, pp. 199–208.
81. Tahai, Alireza & J. Meyer, Michael. (1999). A Revealed Preference Study of Management Journals Direct Influences. *Strategic Management Journal - STRATEG MANAGE J.* 20. 279-296. 10.1002/(SICI)1097-0266(199903)20:33.0.CO;2-2.
82. Treinta, Fernanda Tavares, Farias Filho, José Rodrigues, Sant'Anna, Annibal Parracho, & Rabelo, Lúcia Mathias. (2014). Metodologia de pesquisa bibliográfica com a utilização de método multicritério de apoio à decisão. *Production*, 24(3), 508-520.
83. Uwuigbe, U., Peter, D. S. and Oyeniyi, A. (2014) 'The effects of corporate governance mechanisms on earnings management of listed firms in Nigeria', *Accounting and Management Information Systems* Vol. 13, No.1, pp.159-174.
84. Vergara, S. C. *Projetos e Relatórios de Pesquisa em Administração*. 15. ed. São Paulo: Atlas, 2014.
85. Verleun, Georgakopoulos, Sotiropoulos, and Vasileiou (2011), The Sarbanes-Oxley Act and Accounting Quality: A Comprehensive Examination, *International Journal of Economics and Finance*, Vol. 3, No. 5, pp. 49-64.
86. Villalonga, B., & Amit, R. (2004). How do family ownership, control, and management affect firm value? Harvard Business School and Wharton School, University of Pennsylvania.
87. Wang, D. (2006). Founding family ownership and earnings quality. *Journal of Accounting Research*, 44(3), 619-656.
88. Watts, R., & Zimmerman, J. (1986). *Positive Accounting Theory*, Edgewood Cliffs, NJ: Prentice Hall.

89. Wellalage, N.H., Locke, S. & Scrimgeour, F. (2012). Does one size fit all? An empirical investigation of board structure on family firms' financial performance. *Afro-Asian Journal of Finance and Accounting*, 3(2), 182-194.
90. Wong, L. (2011). Corporate governance in small firms: The need for cross-cultural analysis? *International Journal of Cross Cultural Management*, 11(2), 167–183. <https://doi.org/10.1177/1470595811399188>
91. Yoon, S. (2007). *Accounting Quality and International Accounting Convergence* (Doctoral dissertation, Oklahoma State University) - Oklahoma State University, Oklahoma.
92. Zahra, S., & Sharma, P. (2004). Family business research: A strategic reflection. *Family Business Review*, 17(4), 331–346.
93. Zellweger, T. M., Nason, R. S., & Nordqvist, M. (2011). From longevity of firms to transgenerational entrepreneurship of families: Introducing family entrepreneurial orientation. *Family Business Review*, 25(2), 136-155. doi:10.1177/0894486511423531.
94. Zupic, I.; Cater, T. Bibliometric methods in management and organization. *Organizational Research Methods*, v.18, n.3, p.429–472, 2015.

## GAMIFICATION IN MARKETING – A FAD OF CURRENT TIMES?

**Lubica Gajanova**

*University of Zilina, Faculty of Operation and Economics of Transport and Communication  
Department of Economics, Univerzitna 8215/1, 010 26 Zilina, Slovak Republic  
lubica.gajanova@fpedas.uniza.sk*

### **ABSTRACT**

*Games can use effective methods to motivate players to achieve the best possible results. It is no surprise, then, that this philosophy began to be used in other areas as well. And this is exactly the main purpose of gamification, which seeks to use this specific way of motivation, e.g. to increase work performance, improve learning outcomes or, in the case of marketing, increase sales or brand awareness. Gamification aims to target customers through playful ways in the company's external environment. However, the goal is not to force customers to participate in these games. Rather, it seeks to adjust well-established processes to make them more fun and playful for customers. Gaming mechanisms are then a way to increase customer loyalty to products or brands. Gamification thus essentially adds gameplay elements to the existing activity in order to produce the desired motivational or behavioral effects. The aim of the paper is to focus on the concept of gamification only in the marketing context, to summarize the pros and cons and future of this attribute as a whole as well as by concentrating on the usability of aspect of this kind in terms of psychographic lifestyle generational segmentation of end users (customers). The paper presents a summary and analysis of various secondary data of scientific as well as practical nature. The results of the analysis clearly show, despite the existence of negative opinions on the analyzed issues and a significant number of unsuccessful implementation attempts, that a well-designed gamification achieves the goals set naturally and so we cannot consider the use of gamification in marketing as a fad of current times.*

**Keywords:** *Gamification, Marketing communication, Psychgraphic segmentation*

### **1. INTRODUCTION**

Gamification refers to the use of game mechanics and motivational processes in areas unrelated to the game. The concept of gamification was first used in 2002, on the web site of consultant Nick Pelling, who offered a playful hardware enhancement, i.e. the principle of using gaming elements in non-gaming environments. Gamification gives a name to a phenomenon that began to emerge in marketing practice long before the gaming industry was built as we know it today and before the term was widely used. Already in 1896, a loyalty program was introduced in which customers collected stamps of various partner companies, which they could subsequently exchange for rewards. This loyalty program is often referred to as the beginnings of gamification in marketing (Havel, 2019). There are different definitions of gamification, but neither is generally accepted. The most common definition is: The use of gaming elements in a non-gaming environment. This definition needs to be divided from several aspects. First of all, we need to realize that we are talking about elements of the game, not playing. Gamification must therefore be distinguished from a kind of playful interaction, playful design or playfulness. Ultimately, however, designing gamification applications should lead to playful behavior and mindset (Drugău-Constantin, 2019).

### **2. THE GAMIFICATION IN THE MARKETING CONCEPT**

The Oxford Dictionary defines gamification as application of typical elements of game playing (e.g. point scoring; competition with others; rules of play) to other areas of activity, typically as an online marketing technique to encourage engagement with a product or service. In their

publication on the implementation of game elements in web and mobile applications, Zichermann and Cunningham (2011) define gamification as process of game-thinking and game mechanics to engage users and solve problems. It follows from their definition that the main goal of gamification is to achieve interaction with the customer, and on its basis it is possible to achieve the desired goal (Alani et al., 2019; Kliestikova et al., 2018). Problem solving is viewed flexibly, according to the authors, gamification can be applied to any problem that can be solved by influencing human motivation and behaviour (Graessley et al., 2019; Princes, 2019). Chaffey (2016) defines gamification as the process of applying game principles and mechanics to ordinary activity in order to actively engage customers through their reward, engagement or amusement. The goal of successful application of gamification elements should be to increase customer loyalty. Burke (2014) argues that gamification focuses on motivating players to meet their goals with the intention of meeting the specific goals of the organization that implements gamification. Gamification in marketing is integrated into an external form of gamification, which aims to target customers through playful ways in the external environment of the company. However, the goal is not to force customers to participate in these games. Rather, companies are trying to adjust well-established processes to make them more fun and playful for their customers. Gaming mechanisms are then a way for customers to become addicted to the company and be more loyal to its products or brand (Krizanova, et al., 2013). In general, gamification is considered to be a system that can force customers to enjoy participating in business services, resulting in increased customer loyalty or increased customer retention (Asquer, 2014).

### **3. GAMIFICATION ACCORDING DEMOGRAPHIC AND PSYCHOGRAPHIC CUSTOMER SEGMENTATION**

The first step in designing a suitable gamification plan is to understand the players. All people who should be affected by gamification are considered as players. The whole success or failure of gamification is directly based on the level of understanding of players, their needs, interests and problems that they normally solve. The more knowledge about the players is available, the better the gamification plan can be designed and then modified and the more successful it will be. Persona, which is a tool used in prototyping, can be used to design gamification. Personas are archetypes of people that are created on the basis of a thorough survey of users of a given system, in our case players. Each persona is a fictitious player who represents an existing group of players, homogeneous segments that are connected by similar elements, whether it is social or demographic and psychographic characteristics, personal goals, cultural background and more (Bartosik-Purgat, 2018; Valaskova et al., 2018). Personas help significantly in the design process. Thanks to them, even a large number of players can be characterized into several representative characters, which will help keep attention on the target player and his needs. They create the impression of a real player. So gamification designer can better empathize with end users, which further deepens their understanding of their needs and goals. All these steps are necessary for decision-making and prioritization during the design process (Nielsen 2012; Revella 2015). In particular, gender is absolutely critical for setting the basic rules of the game. Studies have shown that women usually play social or exploratory games, various logical games and puzzles. They play less but also hero games or Massive(ly)-Multiplayer Online Role-Playing Game (MMORPG). And very few women play action, competitive, adventure or strategies that, in turn, are the domain of men (Yee, 2017). Equally important is age, especially from the point of view of how different generations approach to game mechanics and how they can be motivated by gamification. The generational market segmentation is common used due to combination of lifestyle as one of the psychographic characteristics of market behavior with other demographic segmentation factors (Michman et al., 2003). Millennials are most associated with the concept of gamification.

They are people who have encountered video games since their youth, so they are used to different types of game mechanics, able to solve problems and also overcome failures. They love fun, play, design, competition and also comparison. They prefer a social and serious game in which they can achieve victory. Such players are, of course, very suitable material for gamification, they accept it more easily (Pinzaru et al., 2013; Persson, 2019; Reicher, 2018; Chakraborty & Balakrishnan, 2017; Diaz-Samiento et al., 2017; Fromm & Garton, 2013). Gamification in Millennials has positive and significant indirect effects on behavioural intention through the flow state (García-Jurado et al., 2013) Flow theory by Csikszentmihalyie is a mental state in which a person performing an activity is fully immersed in a sense of energizing concentration, full interest and enjoyment of the process of the activity. The state of flow arises from a demanding activity requiring skill, when it combines action, focuses on itself, has clear goals, direct and immediate feedback, focuses on immediate subtasks, provides a sense of control of the situation, leads to reduced self-perception and its surroundings, changing the perception of time. Reaching a flow indicates the state in which a player is between desire and boredom and meets their own motivational levels in this experience (Jirkovský, 2012). Gamification is not limited to the millennial generation. The challenge and reward mechanism affects any generation. But members of this generation have grown up in games and are more connected to this mechanism. The average age of people playing computer games is 35, but the age distribution of players is relatively even. So it is obvious that people play computer games at all ages (Lofgren 2017; Statista, 2019). So games are not just a matter of young people, a relatively large number of players are also older people, so it is necessary to deal with motivation in this regard. In the case of the Generation X, it has been detected that flow interferes in its perception of ease of use (García-Jurado et al., 2019). Because members of generation Z are looking to become the biggest group of consumers by 2020 (Barkleyus, 2018) it is appropriate to pay close attention to them in connection with gamification and thus to engage and involve them. This generation naturally uses fast pace technology, whilst simultaneously have notoriously short attention spans. Gaming is almost synonymous with this generation. Gamified content provides the exact type of content this generation is used to – bite-sized, visual and highly addictive (Simms, 2019). As for the element of strategy, it hardly changes with age, which makes strategies a solid foundation that will appeal to every age group (Yee 2016). So gamification may be successfully applied in loyalty marketing to all generations. Personalization of gamified experiences is very important to get maximum benefits with gamification because of differences between responses to gamification elements by different demographics and psychographics (Jar Creative, 2014).

#### **4. THE PROS AND CONS OF MARKETING GAMIFICATION**

Positive effect of gamification is compounded by the fact that its various forms and variants are all around us. When playing, we feel full use of our abilities, we have fun and we feel good. When users have fun, they build a positive relationship with a particular brand or product that gives them that feeling (Zéman & Bogdan, 2019, Palus et al., 2014). Feeling good encourages us to return to a certain thing (Zlatohlávek, 2011). Very often in practice, the gaming experience itself is significantly stronger than the benefits offered by the program. Gamification should therefore have a positive effect on the motivation of users of projects or processes. Whether it is a project to increase sales, productivity, loyalty or involvement, evaluating users' activities with points and rewards gives them the feeling that their activity leads to a clear result, they have feeling of well-spent time and keep coming back to the application. Through gamification, organizations can take back control of creating a brand experience and engaging the user (Plessis, E. 2011). By using innovation and knowledge about users in a progressive form of marketing communication, companies are able to achieve a competitive advantage (Sroka et al., 2014; Lizbetinova et al., 2019, Lizbetinova et al., 2020; Moravcikova et al., 2017).



Gamification thus makes it possible to turn a regular customer into a loyal fan. With it, retailers can increase brand awareness, affinity and influence purchasing decisions (Deterding, 2011). It is already quite clear that the use of gamification in marketing is not just another bloated bubble, but a regular and successful technique with a future. According to a study by Gigya, whose clients include Pepsi, Nike or Dell, implementing gamification into a web service can increase customer engagement on average (ie comment, share, discover new relevant content, participate in other activities) by almost one-third (Kuo, 2013). Audiences spend more time on websites and return to related social media. The more a user communicates with the web, less motivated to click on another resource and the more loyal they are. The main benefits of this technique, in connection with its use in the field of social networks, include maintaining the attention of the user/fan for a long time or repeatedly, enriching old principles functions to enjoy their reuse, increasing engagement and establishing closer relationships with fans/customers (Zadáková, 2018). In 2010, even Jesse Schell, director of Schell Games, said that in the years to come, every moment of our lives would be a game and people would do certain activities just for points (Schell, 2010). Internal motivation must be found in users. If gamification is based only on external motivation, i.e. collecting points or badges, then has a short-term effect. People can start looking for the easiest way to come to points, they can start cheating. One solution in this situation would be to use rewards that make no sense anywhere other than in the game and try to make cheating more complicated than playing. Critics of gamification are of the opinion that this is human manipulation. The loss of the original meaning of a gamified application and the effort to gain points just for have them, is one of the features of an inappropriately gamified project and one of the reasons why gamification can fail. Gartner, research and advisory company, says by 2014, 80 percent of current gamified applications will fail to meet business objectives (Kuo 2013). And it's mainly because they were made by people who didn't know what they were doing. Solution design in the form of gamification is a complex process, requiring an almost endless list of knowledge - game design, marketing, sales, internal company processes, psychology, sociology, or even the design of services. Gamification needs to be seen in the whole context, not as solutions that arise in a hurry and especially in a vacuum on the basis that it is a trend right now. Bogost (2011) accuses marketers of trying to use the magical, adventurous aura of games for boring and grey sales purposes, over and over again, in recyclable form. And he's right, but only halfway. Because he's just talking about the miserable gamification. The well-designed one does not need to impress, disguise or force. The well-designed one achieves the goals naturally. And the basis, of course, is that it's built on something that works. Properly created and used gamification can be an unforgettable experience for the customer to share with their loved ones (Daisyme, 2017).

## **5. THE FUTURE OF MARKETING GAMIFICATION**

Kapp (2013) believes that gamification will continue to grow. It envisages the development of gamification in three key areas, which are: the growth of more gaming system interfaces, an increased focus on performance, and the areas of virtual and augmented reality. He is of the opinion that gamification is still growing and in the future game elements will be added to all systems and new game interfaces will be created. Gamification is increasingly expected to be linked to trading systems and operations wherein game elements will be directly related to the performance of employees. The last area of growth with the greatest potential is virtual and augmented reality, in which gamification will have a major impact (Jacobs, 2017). Gamification have to be linked to social elements. According to Gigya's Marketing Manager, Victor White, gamification is often thought to be social inherently, but it's not – there's a difference between getting a badge, and getting a badge and sharing it. One is social, and one is not (Koetsier, 2013).

Already in 2019, in order to increase engagement and maintain customer attention (also in advertising), many new elements of gamification were introduced into the various functions offered by social networks. These are various gadgets such as gifs, polls, Emoji Sliders, Music Stickers, and Question Stickers, which enrich the already established and everyday functionalities of social networks. In the future, social networks will offer countless game aspect tweaks, because everyone strives for one thing - to keep the user's constant attention, long-term and repeatedly (Zadáková, 2018).

## 6. CONCLUSION

Although it may not be obvious at first glance, gamification is now almost all around us. It is usually a very simple form without a more complicated design, but we encounter elements of gamification on a daily basis without realizing it. The main reason for this phenomenon is that games played an important role in our childhood and accompanies us throughout life, as they provide people of all generation opportunity to at least short-term relaxation from everyday stereotypes and help to release tension and stress. The paper presents a summary and analysis of various secondary data of scientific as well as practical nature of the issue of gamification. The results of the analysis clearly show, despite the existence of negative opinions on the analysed issues and a significant number of unsuccessful implementation attempts, that a well-designed gamification achieves the goals set naturally and so we cannot consider the use of gamification in marketing as a fad of current times.

**ACKNOWLEDGEMENT:** *This paper is an output of scientific project VEGA no. 1/0718/18: The impact of psychographic aspects of pricing on the marketing strategy of companies across products and markets.*

## LITERATURE:

1. Alani, E., Kamarudin, S., Alrubaiee, L., & Tavakoli, R. (2019). A model of the relationship between strategic orientation and product innovation under the mediating effect of customer knowledge management. *Journal of International Studies*, vol. 12, no. 3, pp. 232-242.
2. Awquer, A. (2014). Not Just Videogames: Gamification and its Potential Application to Public Services. Retrieved 02.05.2020 from [https://papers.ssrn.com/sol3/papers.cfm?abstract\\_id=2429345](https://papers.ssrn.com/sol3/papers.cfm?abstract_id=2429345)
3. Barkleyus (2018). The power of Gen Z influence: Marketing to Gen Z™. Retrieved 02.05.2020 from <http://www.millennialmarketing.com/research-paper/the-power-of-gen-z-influence/>
4. Bartosik-Purgat, M. (2018). Country of origin as a determinant of young Europeans` buying attitudes — marketing implications. *Oeconomia Copernicana*, vol. 9, no. 1, pp. 123-142.
5. Bogost, I. (2011). Gamification is Bullshit. Retrieved 02.05.2020 from [http://bogost.com/writing/blog/gamification\\_is\\_bullshit/](http://bogost.com/writing/blog/gamification_is_bullshit/)
6. Burke, B. (2014). *Gamify: How gamification motivates people to do extraordinary things*. Brookline, MA: Biblotion. 195 p.
7. Chaffey, D., Ellis-Chadwick, F. (2016). *Digital Marketing. Strategy, implementation and practice*. Pearson Education Limited. 728 p.
8. Chakraborty, T., Balakrishnan, J. (2017). Exploratory tendencies in consumer behaviour in online buying across gen X, gen Y and baby boomers. *International journal of value chain*, vol. 8, no. 2, pp. 135-150.
9. Daisyme, P. (2017). How To Add Gamification To Your Marketing Strategy. Retrieved 02.05.2020 from <https://www.forbes.com/sites/theyec/2017/06/22/how-to-add-gamification-to-your-marketing-strategy/#5658fecb5b3b>

10. Deterding, S., Sicart, M., Nacke, L., O'Hara, K., Dixon, D. (2011). Gamification: Using Game Design Elements in Non-Gaming Contexts. Retrieved 02.05.2020 from <http://gamification-research.org/wp-content/uploads/2011/04/01-Deterding-Sicart-Nacke-OHara-Dixon.pdf>
11. Diaz-Samiente, C., Lopez-Lambrano, M., Roncallo-Lafont, L. (2017). Understanding generations: a review of the concept, classification and distinctive traits among baby boomers, generation X and millennials. *Clio America*, vol. 11, no. 22, pp. 188-204.
12. Drugău-Constantin, A. (2019). Is Consumer Cognition Reducible to Neurophysiological Functioning?. *Economics, Management, and Financial Markets*, vol. 14, no. 1, pp. 9-14.
13. Fromm, J., Garton, C. (2013). *Marketing to Millennials: Reach the Largest and Most Influential Generation of Consumers Ever*. New York: AMACOM. 224 p.
14. García-Jurado, A., Castro-González, P., Torres-Jiménez, M., Leal-Rodríguez, A.L. (2019). Evaluating the role of gamification and flow in e-consumers: millennials versus generation X. *Kybernetes*, vol. 48, no. 6, pp. 1278-1300.
15. Graessley, Scott, Jakub Horak, Maria Kovacova, Katarina Valaskova, and Milos Poliak (2019). Consumer Attitudes and Behaviors in the Technology-Driven Sharing Economy: Motivations for Participating in Collaborative Consumption. *Journal of Self-Governance and Management Economics*, vol. 7, no. 1, pp. 25-30.
16. Havel, B. (2019). Gamifikace ve výuce. Retrieved 02.05.2020 from <https://spomocnik.rvp.cz/clanek/21961/GAMIFIKACE-VE-VYUCE.html>
17. Jacobs, S. (2017). The Future of Gamification. Retrieved 02.05.2020 from <https://www.learningsolutionsmag.com/articles/2369/the-future-of-gamification>
18. Jar Creative (2014). Gamification, Mobile Marketing and Baby Boomers. Retrieved 02.05.2020 from <https://www.jarcreative.com/e-commerce/gamification-mobile-marketing-baby-boomers/>
19. Jirkovský, J. (2012). *Game Industry 2*. Praha: D.A.M.O. 240 p.
20. Kapp, K.M. (2013). *The Gamification of Learning and Instruction Fieldbook: Ideas into Practice*. Wiley. 480 p.
21. Klietkova, J., Krizanova, A., Corejova, T., Kral, P., Spuchlakova, E. (2018). Subsidies to Increase Remote Pollution? *Science and Engineering Ethics*, vol. 24, no. 2, pp. 755-767.
22. Krizanova, A., Majerova, J., Klietk, T., Majercak, P. (2013). Theoretical Aspects of Brand Building in Seafood Industry. *NAŠE MORE*, vol. 60, no. 5-6, pp. 105-112.
23. Koetsier, J. (2013). Billions of online user actions say gamification increases site engagement 29%. Retrieved 02.05.2020 from <https://venturebeat.com/2013/03/26/billions-of-online-user-actions-say-gamification-increases-site-engagement-29/>
24. Kuo, I. (2013). Gigya's Social Gamification Boosts Content Discovery by 68%. Retrieved 02.05.2020 from <https://www.gamification.co/2013/03/28/gigya-boosts-content-discovery/>
25. Lizbetinova, L., Starchon, P., Lorincova, S., Weberova, D., Prusa, P. (2019). Application of Cluster Analysis in Marketing Communications in Small and Medium-Sized Enterprises: An Empirical Study in the Slovak Republic. *Sustainability*, vol. 11, no. 8, art. no. 2302.
26. Lizbetinova, L., Starchon, P., Weberova, D., Nedeliakova, E., Jurikova, M. (2020). The Approach of SMEs to Using the Customer Databases and CRM: Empirical Study in the Slovak Republic. *Sustainability*, vol. 12, no. 1, art. no. 227.
27. Lofgren, K. (2017). 2017 Video Game Trends and Statistics – Who's Playing What and Why?. Retrieved 02.05.2020 from <https://www.bigfishgames.com/blog/2017-video-game-trends-and-statistics-whos-playing-what-and-why/>
28. Michman, R.D., Mazze, E.M., Greco, A.J. (2003). *Lifestyle Marketing: Reaching the New American Consumer*. Westport: Praeger. 258 p.

29. Moravcikova, D., Krizanova, A., Kliestikova, A., Rypakova, M. (2017). Green Marketing as the Source of the Competitive Advantage of the Business. *Sustainability*, vol. 9, no. 12, art. no. 2218.
30. Nielsen, N. (2013). *Personas - User Focused Design*. Springer. 167 p.
31. Palus, H., Matova, H., Krizanova, A., Parobek, J. (2014). A survey of awareness of forest certification schemes labels on wood and paper products, *Acta facultatis xylologiae Zvolen*, vol. 56, no. 1, pp. 129-138.
32. Persson, K. (2019). Confident millennials: Differences in consumer confidence across five generations. *Economics and Sociology*, vol. 12, no. 4, pp. 257-277.
33. Pinzaru, F., Savulescu, R., Mitan, A. (2013). New practices in marketing to Generation Y. product placement in Romanian pop music videos. *International Journal Of Academic Research*, vol. 5, pp. 320-326.
34. Plessis, E. *Jak zákazník vnímá značku*. Brno: Computer Press. 247 p.
35. Princes, E. (2019). Boosting impulse buying behaviour in marketing management: customer satisfaction perspective. *Polish Journal of Management Studies*, vol. 20, no. 2, pp. 403-413.
36. Reicher, R. Z. (2018). Hungarian millennials' attitudes on being online. *Forum Scientiae Oeconomia*, vol. 6, no. 1, pp. 5-18.
37. Revella, A. (2015). *Buyer Personas: How to Gain Insight into your Customer's Expectations, Align your Marketing Strategies, and Win More Business*. Wiley. 231 p.
38. Simms, B. (2019). 5 benefits of using gamification in your digital marketing strategy. Retrieved 02.05.2020 from <https://www.digitalmarketing-conference.com/5-benefits-of-using-gamification-in-your-digital-marketing-strategy/>
39. Sroka, W., Cygler, J., Gajdzik, B. (2014). The Transfer of Knowledge in Intra-Organizational Networks: A Case Study Analysis. *Organizacija*, vol. 47, no. 1, pp. 24-34.
40. Statista (2019). Age breakdown of video game players in the United States in 2019. Retrieved 02.05.2020 from <https://www.statista.com/statistics/189582/age-of-us-video-game-players-since-2010/>
41. Sutter, J.D. (2010). Why games will take over our lives. Retrieved 02.05.2020 from <http://edition.cnn.com/2010/TECH/04/05/games.schell/index.html>
42. Valaskova, K., Kliestikova, J., Krizanova, A. (2018). Consumer Perception of Private Label Products: An Empirical Research. *Journal of Competitiveness*, vol. 10, no. 3, pp. 149-163.
43. Yee, N. (2016). As Gamers Age, The Appeal of Competition Drops The Most. Strategy is The Most Age-Stable Motivation. Retrieved 02.05.2020 from <https://quanticfoundry.com/2016/02/10/gamer-generation/>
44. Yee, N. (2017). Beyond 50/50: Breaking Down The Percentage of Female Gamers by Genre. Retrieved 02.05.2020 from <https://quanticfoundry.com/2017/01/19/female-gamers-by-genre/>
45. Zadáková, D. (2018). Trendy na sociálních sítích v roce 2019. Co by vám nemělo uniknout?. Retrieved 02.05.2020 from <https://www.evisions.cz/blog-2018-11-12-trendy-na-socialnich-sitich-v-roce-2019-co-by-vam-nemelo-uniknout/>
46. Zéman, Z., Bogdan, A. (2019). Marketing strategy and building brand value on the Hungarian market. *Ekonomicko-manazerske spektrum*, vol. 13, no. 2, pp. 1-9.
47. Zichermann, G., Cunningham, C. (2011). *Gamification by design: Implementing game mechanics in web and mobile apps*. O'Reilly Media. 182 p.

## **SOME CRITICAL REMARKS TO THE CONCEPT OF LOVE BRANDS IN CONTEMPORARY CRISIS OF INTERPERSONAL RELATIONS**

**Jana Majerova**

*University of Zilina, Faculty of Operation and Economics of Transport and Communications,  
Department of Economics, Slovak Republic  
jana.majerova@fpedas.uniza.sk*

**Margareta Nadanyiova**

*University of Zilina, Faculty of Operation and Economics of Transport and Communications,  
Department of Economics, Slovak Republic  
margareta.nadanyiova@fpedas.uniza.sk*

**Lubica Gajanova**

*University of Zilina, Faculty of Operation and Economics of Transport and Communications,  
Department of Economics, Slovak Republic  
lubica.gajanova@fpedas.uniza.sk*

### **ABSTRACT**

*The phenomenon of love brands faces to one of the biggest contemporary social challenges, which lies in the schism of interpersonal relations. While concept of love brands forms platform for creating loyal basis of consumers who unconditionally prefer chosen brand, the pattern of interpersonal dynamics connected to the partnership and its aspects is quite different. Actual statistics about divorces and number of life partners have growing tendencies. Thus, we cannot state that love is the core emotion for brand value building and management on the long-term perspective. At least we cannot state it generally. As in society, also in case of brands – this emotion seems to be effective in some cases. This is the reason why the elementary research presented in this paper has been realized. In scope of above mentioned, the aim of this paper is to detect and describe on the interdisciplinary approach the dynamics of brands management and mechanisms which function inside between these brands and consumers. To acquire this, there have been set hypotheses connected with different perception of love in two basic dimension – consumer vs. brand and consumer vs. consumer. Based on the provided literature review, it has been supposed, that selected demographic criteria would be relevant to predict the character and depth of these relationships. On the other hand, it has been also supposed that love brands have shorter duration of interaction with consumer than previously. Primary data used in the presented study were obtained by our own survey carried out on the sample of 2000 respondents (citizens of the Slovak Republic older than 15 years). Set hypotheses were tested using binomial test. By providing this statistical evaluation of obtained data, it has been subsequently possible to identify suitable methodological apparatus for optimization of so far formulated postulates of the concept of love brands and its effective implementation in contemporary practice of brand value building and management.*

**Keywords:** *Brand, Branding, Love Brands, Interpersonal Relations*

### **1. INTRODUCTION**

Love is a delicate issue. It is multifaceted, both subjectively and objectively. It is lost equally as it is found in the complex folds of the unique dynamics of mind, body and spirit. It rotates like a spiral, both inwards and outwards. People know the "feeling" of love, but they don't seem to be able to describe it. Unfortunately, the prevailing paradigm of love in our culture is egocentric - it is love based on property. Contemporary world is based on relationships which are built mostly on materialism, ownership and immediate satisfaction. It is almost as if people

would be conditioned to consume to such an extent that they "consume" each other. Even the words they use among themselves to express love indicate ownership. However, the paradigm of love can be updated. But first of all, the recognition of each other as opposite sides of the same being has to be provided (Mirica, 2018). The ability to love another person is determined by the ability to love ourselves. The irony is that first of all, people has to learn self-love. Thus, it is essential to love ourselves to understand that egocentric love is not the healthiest way to love. People must first love own ego in order to turn it into an ego that is not just in love with itself. The ego, which is not loved, tends to become self-serving and egocentric (dependent or only independent). However, the ego that is loved tends to update and become mentally oriented (interdependent). The ego that has learned interdependence through self-love will more than likely love authentically. It will be more than likely vulnerable to other egos. And vulnerability is the key to great love. It is a secret of deep authenticity. A key aspect of self-actualized love, as opposed to egocentric love, is that it is allowed ourselves to be vulnerable. It sounds pretty simple, but its simplicity is only illusion. It requires good communication skills, great sincerity and exemplary trust between partners. One of the biggest assumptions which has been made about love is that people imagine that the other person loves in the same way they love. In other words, people assume that what another person understands by the term love means the same thing it means to them (Nica, 2018). But this cannot be true if people honestly allow the other person to be an individual with their own unique tastes and opinions.

The ability to let love go is the ability to let go our ego's attachment to it. Falling in love is very easy and at the same time very difficult. It is easy when we come from a place of independence and interdependence; when we allow all things to proceed in a mysterious and majestic flow. But it's hard when we come from a place of attachment and addiction and try hard to control everything. It is the difference between what love is and a futile attempt to classify love into the box of our expectations. When people let love go, they don't let love go the essence of love - not at all. They let go the ego aspect of this love. They let go the attachment and the need to cling. Love itself is never abandoned, nor is it forgotten. It is only dependence, addiction, the ego side of love, which is filled with unhealthy expectations, and cultural predispositions about the way love should be abandoned. Authentic love lasts forever, in spite of us, and even in spite of our egos. This mechanism of love remains identical regardless the object of love – i.e. it doesn't matter if we discuss love interactions between partners or love interactions between person and brand. So-called "love brands" – also sometimes called "lovemarks" – are brands that exert such strong attraction on consumers that they are not only preferred over other brands but are actually "loved" (Shpak et al., 2018). Consumers often remain loyal to their love brand for years or even all of their lives (Domanska, 2018). They generously forgive mistakes. This is based on a deep relationship of trust between fan and brand. They are also immune to price increases – the high level of personal identification with the brand core values is more important than a price advantage. But caution is advised: Unlike unconditional love between two people, the love between fan and brand is an egotistical one. Those who do not offer true added value, stand apart with an individual brand character, and fail to provide a positive customer experience, will never reach the status of love brand. The extant literature on brand love lacks appraisal of theories and discourse on the conceptualizations of brand love. Junaid et al. (2019) differentiate these conceptualizations, categorizes in three mutually exclusive forms, and labels as perfect two-way love, imperfect two-way love, and perfect one-way love. Using a grounded theory approach, Batra et al. (2012) investigate the nature and consequences of brand love. Arguing that research on brand love needs to be built on an understanding of how consumers actually experience this phenomenon, they conduct two qualitative studies to uncover the different elements ("features") of the consumer prototype of brand love.

Then, they use structural equations modeling on survey data to explore how these elements can be modeled as both first-order and higher-order structural models. A higher-order model yields seven core elements: self brand integration, passion-driven behaviors, positive emotional connection, long-term relationship, positive overall attitude valence, attitude certainty and confidence (strength), and anticipated separation distress. In addition to these seven core elements of brand love itself, the prototype includes quality beliefs as an antecedent of brand love and brand loyalty, word of mouth, and resistance to negative information as outcomes. Traditionally, brand love research focuses on the aspect of incorporation of this phenomenon into complex brand value building and management pattern. Thus, Dass et al. (2020) examine the connections between brand experience, brand love and brand trust in the context of business schools. Isolated view on the concept of love brand in its multidimensional prospective is missing as contemporary scientific attention is paid mostly on the implementation of this concept in specific brand conditions (Sroka & Szanto, 2018; Trivedi, 2020; Mody & Hanks, 2020). Zhang et al. (2020) conduct their study from the strategic marketing perspective to test the impact of brand relationship types on brand loyalty. They also test three path effects of brand love and brand trust. The results indicate that an expressive brand relationship significantly predicts brand trust and brand loyalty. In turn, brand trust has a positive influence on brand love, while brand awareness and brand love influence attitudinal and behavioral loyalty. Expressive brand relationship has two indirect mediating affects via brand trust and brand love, which influence brand loyalty. Recently, also another strong polarized emotion is discussed in scope of brand management (Stonkute et al. 2018). Ma (2020) state that although non-identifying relationships offer buffering effects, identifying relationships primarily offer love-becomes-hate effects by intensifying negative emotions such as anger and disappointment, which in turn affect consumers' behavioral intentions. Such patterns hold regardless of whether a crisis directly threatens the core meaning of the brand. Similarly, also Rodrigues and Borges (2020) evaluate the effect of the scandals and distrust over the past years in brand love regarding a classic and well-known financial brand, considering the antecedents of brand love contemplating the role of negative emotions, engagement and authenticity. Figure 1 shows evolution of the love brand concept in scientific literature.

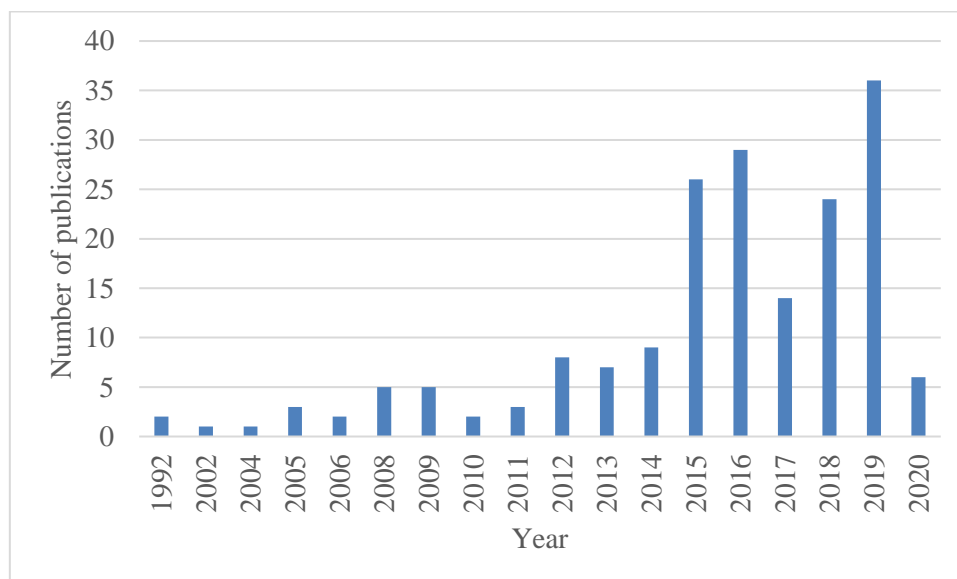

Figure 1: The development of the number of publications on „love brand“ in the Web of Science database (own processing)

## 2. METHODOLOGY AND DATA

According to the literature review above, the basic research problem has been set as the failure of love brands strategy application in contemporary brand value building and management. Thus, it will be possible to create a platform for future research on the relevant branding activities in scope of emotions involvement. To achieve this aim, we have used primary data which was obtained from our own research undertaken during the first six months of 2019 on a socio-demographically representative sample of 2000 respondents (the sample without outliers and incompatible units consisted of 697 respondents). This primary data was collected by means of our own questionnaire survey in the form of computer-assisted web interviewing in accordance with the ICC/ESOMAR International code on Market, Opinion and Social Research and Data Analytics. We used a standardized method of the direct questioning. As a recommended tool of this survey it was chosen a semi-structured written questionnaire. The respondents were Slovak residents aged over 15 years (the reason behind such a limitation was their legal labour subjectivity, which forms a basic condition for autonomous purchase-related decision making). In accordance with above mentioned theoretical approaches to the solved research problem and knowledge about Slovak consumer's specifics (Valaskova & Krizanova, 2008), the hypotheses of the research were set:

Hypothesis H1: The internal perception of own personality has an impact on consumer attitude towards love brand.

Hypothesis H2: The conformity with social group as a leading brand love motive has not got an impact on brand loyalty.

In context of formulated hypotheses and their testing methods, we consider as appropriate to explain how the "majority" was quantified. We refer to Olah et al. (2019). According to their theory, the majority can be considered more than 50% of the analyzed trait occurrence. Hypotheses were tested using binomial test (H1 and H2) – the binomial test uses the binomial distribution to decide if the outcome of an experiment in which we count the number of times one of two alternatives has occurred (Lizbetinova et al., 2019). According to Palus et al. (2014), the following characteristics were used for the hypotheses testing (1):

$$t = \frac{|\bar{x} - \mu|}{\sigma} \Rightarrow \frac{x - np}{\sqrt{npq}} = \frac{\frac{x}{n} - \frac{np}{n}}{\frac{\sqrt{npq}}{n}} = \frac{\tilde{p} - p}{\sqrt{\frac{pq}{n}}} \quad (1)$$

where:

- x the frequency of the trait,
- n the frequency of observed phenomena,
- p predicted probability of the phenomenon incidence,
- q probability of alternative phenomenon frequency,
- $\tilde{p}$  statistical probability of the phenomenon incidence.

## 3. RESULTS AND DISCUSSION

We verified hypotheses using the binominal test. This test serves to reject or accept the null hypothesis  $H_0$  (Bartosova et al., 2015).

### 3.1 Verification of hypothesis H1

- Hypothesis H0: The internal perception of own personality has not an impact on consumer attitude towards love brand.



- Hypothesis H1: The internal perception of own personality has an impact on consumer attitude towards love brand.

After the equation (1) substitution, the value of testing characteristic was calculated (8,453). The critical testing characteristic was calculated through the Microsoft Excel, using the function NORMINV (0,05; 0; 1). The resulting value was -1,523 ( $t_k$ ). To accept the null hypothesis ( $H_0$ ) which is the object of verification, the “t” value has to be minor than “ $t_k$ ” value. As the “ $t_k$ ” value is minor than “t” value ( $8,453 > -1,523$ ), the null hypothesis ( $H_0$ ) is rejected and we accept the alternative hypothesis ( $H_1$ ) at the significance level of 0,05.

Thus, we can conclude that *the internal perception of own personality has an impact on consumer attitude towards love brand*.

### 3.2 Verification of hypothesis H2

- Hypothesis  $H_0$ : The conformity with social group as a leading brand love motive has not got an impact on brand loyalty.
- Hypothesis  $H_1$ : The conformity with social group as a leading brand love motive has an impact on brand loyalty.

After the equation (1) substitution, the value of testing characteristic was calculated (-1,73). The critical testing characteristic was calculated through the Microsoft Excel, using the function NORMINV (0,05; 0; 1). The resulting value was -1,455 ( $t_k$ ). To accept the null hypothesis ( $H_0$ ) which is the object of verification, the “t” value has to be minor than “ $t_k$ ” value. As the “ $t_k$ ” value is mayor than “t” value ( $-1,455 < -1,73$ ), we can accept null hypothesis ( $H_0$ ) and rejected the alternative hypothesis ( $H_1$ ) at the significance level of 0,05.

Thus, we can conclude that *the conformity with social group as a leading brand love motive has not got an impact on brand loyalty*.

According to these results, we can provide a critical discussion in the light and shadow of contemporary state of scientific knowledge. As it has been highlighted above, the concept of love brands is developing quickly in last years. One of possible reasons is the decrease of brand value of Coca Cola as a traditionally perceived love brand (Interbrand, 2020). Thus, the critical aspects of the implementation of love brand concept have to be discovered on the case study of this iconic love brand. Otherwise, brands would be endangered by incorporating the love brand concept into their own practice of brand value building and management. But this concept shouldn't be refused in general. On the other hand, it should be modified to meet expectations of consumers. Optimal way how to do this is to treat it as another human being and to apply knowledge about the dynamics of interpersonal relationships into the practice of emotions based branding. Also actual statistics about divorces and number of life partners have growing tendencies. Thus, we cannot state that love is the core emotion for brand value building and management on the long-term perspective. At least we cannot state it generally. As in society, also in case of brands – this emotion seems to be effective in some cases. And first of all – it has to be accepted the fact that the ability to love another person is determined by the ability to love ourselves. In scope of this fact – love brand concept has the power to build valuable brand only if it is connected with real knowledge of consumer. In other words – brands which are focused on the aspiration with social group are more likely to fail with love brand concept than brands who accept consumer and his specifics. Thus, brands shouldn't create ideal which consumer would like to reach, but they should accept specifics of consumers. Very good example of this approach is brand Dove and its campaign “*Real Beauty*” which puts into the center of brand perception the own reconciliation with own specificity and uniqueness.

#### 4. CONCLUSION

Thus, we cannot state that love in its actual perception is the core emotion for brand value building and management on the long-term perspective. This is the reason why the elementary research presented in this paper has been realized. The aim of this paper is to detect and describe on the interdisciplinary approach the dynamics of brands management and mechanisms which function inside between these brands and consumers. To acquire this, there have been set hypotheses connected with different perception of love in two basic dimension – consumer vs. brand and consumer vs. consumer. Primary data used in the presented study were obtained by our own survey carried out on the sample of 2000 respondents (citizens of the Slovak Republic older than 15 years). Set hypotheses were tested using binomial test. By providing this statistical evaluation of obtained data, it has been subsequently possible to identify suitable methodological apparatus for optimization of so far formulated postulates of the concept of love brands and its effective implementation in contemporary practice of brand value building and management. We found out that 1) the internal perception of own personality has an impact on consumer attitude towards love brand and 2) the conformity with social group as a leading brand love motive has not got an impact on brand loyalty. Thus, there is a platform to put traditional love brand concept of brand value building and managing under critical revision based on these outcomes of provided research.

**ACKNOWLEDGEMENT:** *This contribution is an output of scientific project VEGA no. 1/0718/18: The impact of psychographic aspects of pricing on the marketing strategy of companies across products and markets.*

#### LITERATURE:

1. Bartosova, V., Majercak, P., Hraskova, D. (2015). Taking risk into account in the evaluation of economic efficiency of investment projects: Traditional methods, *Procedia Economics and Finance*, vol. 24, pp. 68-75. DOI: 10.1016/S2212-5671(15)00614-0.
2. Batra, R., Ahuvia, A., Bagozzi, R.P. (2012). Brand Love, *Journal of Marketing*, vol. 76, no. 2, pp. 1-16. DOI: 10.1509/jm.09.0339.
3. Dass, S., Popli, S., Sarkar, A., Sarkar, J.G., Vinav, M. (2020). Empirically examining the psychological mechanism of a loved and trusted business school brand, *Journal of Marketing for Higher Education*, early access 03/2020. DOI: 10.1080/08841241.2020.1742846.
4. Domanska, A. (2018). Cooperation between knowledge-based institutions and business: Empirical studies and network theories, *Forum Scientiae Oeconomia*, vol. 6, no. 4, pp. 81-94. DOI: 10.23762/FSO\_VOL6\_NO4\_6.
5. Interbrand 2000-2020 (2020). Available on: <https://www.interbrand.com>.
6. Junaid, M., Hussain, K., Hou, F.J. (2019). One last scuffle before we cherish brand love forever, *International Journal of Market Research*, vol. 61, no. 6, pp. 571-573. DOI: 10.1177/1470785319827153.
7. Lizbetinova, L., Starchon, P., Lorincova, S., Weberova, D., Prusa, P. (2019). Application of cluster analysis in marketing communications in small and medium-sized enterprises: An empirical study in the Slovak Republic, *Sustainability*, vol. 11, no. 8, art. no. 2302. DOI: 10.3390/su11082302.
8. Ma, L. (2020). When love becomes hate: How different consumer-brand relationships interact with crises to influence consumers' reactions, *Corporate Communications*, early access 04/2020. DOI: 10.1108/CCIJ-08-2019-0103.

9. Mirica (Dumitrescu), C.O. (2018). Judgments and decision making in consumer behavior: The use of psychophysiological measures to investigate emotions and cognitive responses, *Economics, Management, and Financial Markets*, vol. 13, no. 4. pp: 39-44. DOI: 10.22381/EMFM13420182.
10. Mody, M., Hanks, L. (2020). Consumption authenticity in the accommodations industry: The keys to brand love and brand loyalty for hotels and airbnb, *Journal of Travel Research*, vol. 59, no. 1, pp. 173-189. DOI: 10.1177/0047287519826233.
11. Nica, E. (2018). Gig-based working arrangements: Business patterns, labor-management practices, and regulations, *Economics, Management, and Financial Markets*, vol. 13, no. 1, pp. 100-105. DOI: 10.22381/EMFM13120185.
12. Olah, J., Kovacs, S., Virglerova, Z., Lakner, Z., Kovacova, M., Popp, J. (2019). Analysis and comparison of economic and financial risk sources in SMEs of the Visegrad Group and Serbia, *Sustainability*, vol. 11, no. 7, art. no. UNSP 1853. DOI: 10.3390/su11071853.
13. Palus, H., Matova, H., Krizanova, A., Parobek, J. (2014). A survey of awareness of forest certification schemes labels on wood and paper products, *Acta Facultatis Xylogologiae Zvolen*, vol. 56, no. 1, pp. 129-138.
14. Rodrigues, P., Borges, A.P. (2020). Negative emotions toward a financial brand: The opposite impact on brand love, *European Business Review*, early access 03/2020. DOI: 10.1108/EBR-12-2018-0221.
15. Shpak, N., Sorochak, O., Hvozd, M., Sroka, W. (2018). Risk evaluation of the reengineering projects: A case study analysis, *Scientific Annals of Economics and Business*, vol. 65, no. 2, pp. 215-226. DOI: 10.2478/saeb-2018-0014.
16. Sroka, W., Szanto, R. (2018). Corporate social responsibility and business ethics in controversial sectors: Analysis of research results, *Journal of Entrepreneurship, Management and Innovation*, vol. 14, no. 3, pp. 111-126. DOI: 10.7341/20181435.
17. Stonkute, E., Vveinhardt, J., Sroka, W. (2018). Training the CSR sensitive mind-set: The integration of CSR into the training of business administration professionals, *Sustainability*, vol. 10, art. no. 754. DOI: 10.3390/su10030754.
18. Trivedi, J. (2020). Effect of corporate image of the sponsor on brand love and purchase intentions: The moderating role of sports involvement, *Journal of Global Scholars of Marketing Science*, vol. 30, no. 2, pp. 188-209. DOI: 10.1080/21639159.2020.1717978.
19. Valaskova, M., Krizanova, A. (2008). The passenger satisfaction survey in the regional integrated public transport system, *Promet-Traffic & Transportation*, vol. 20, no. 6, pp. 401-404.
20. Zhang, S.K., Peng, M.Y.P., Peng, Y.P., Zhang, Y., Ren, G.Y., Chen, C.C. (2020). Expressive brand relationship, brand love, and brand loyalty for tablet pcs: Building a sustainable brand, *Frontiers in Psychology*, vol. 11, art. no. 231. DOI: 10.3389/fpsyg.2020.00231.

# **SOCIALLY RESPONSIBLE COMMUNICATION STRATEGY IN THE BANKING SECTOR**

**Margareta Nadanyiova**

*University of Zilina, Faculty of Operation and Economics of Transport and Communications,  
Slovak Republic*

*margareta.nadanyiova@fpedas.uniza.sk*

## **ABSTRACT**

*Corporate social responsibility together with sustainable development, has been one of the most discussed topics in recent years. Its essence lies in the fact that companies focus not only on profit but above all on sustainable growth and development. In addition to their economic activities, they also pay attention to the social and environmental aspects and emphasize that these interests do not have to be contradictory, but conversely, they can work together and thus increase their efficiency. And it is the communication that is crucial in corporate social responsibility and influences the attitudes of stakeholders towards the company. The aim of this article includes providing a literature review on the issue from the perspective of several foreign and domestic authors. By using methods of description, comparison, deduction, induction, it discusses the essence of corporate social responsibility as well as socially responsible communication and also analyses its practical use in the banking sector. The secondary data for the analysis were obtained from annual companies reports, statistical tables and published professional publications. General scientific methods were applied for the processing of the data. Based on this, the benefits of using socially responsible communication strategy in the banking sector are highlighted, that includes, in particular, strengthening the company's image, increasing the brand value, building customer relationships and gaining their loyalty.*

**Keywords:** *Corporate Social Responsibility (CSR), Socially Responsible Communication, Banking Sector, Stakeholders, Company*

## **1. INTRODUCTION**

In the process of globalization, corporate social responsibility (CSR) is becoming a mantra for companies around the world (Sroka & Szanto, 2018). It represents a way for a company to recognize and take responsibility for its activities that affect the market, its employees, society and the environment. Currently, the main goal of business is not only profit but also the well-being of society. The number of companies that practice some form of CSR is growing rapidly worldwide (Krizanova & Gajanova, 2016). Bhattacharya and Sen (2004) emphasize that more than 80 percent of Fortune 500 companies deal with CSR issues, reflecting business leaders' belief that in today's market, CSR is not just an ethical issue but an economic one. In particular, companies realize that CSR can have significant benefits and that it can become part of their successful competitive advantage (Moravcikova et al., 2017; Reicher, 2019). Therefore, important is not why engage in CSR, but rather how do it (Gorgenyi Hegyes & Fekete-Farkas, 2019; Gregova et al., 2016). The key factor is socially responsible communication with stakeholders, i.e. entities in the direct market environment of a company that is complex a system of often controversially interconnected groups of people and individuals - suppliers, creditors, distributors, advisors, government institutions and many other entities that are influenced by the company or have an impact on the company. Without successful communication of CSR activities, the company cannot achieve its goals (Hitka et al., 2017; Lizbetinova et al., 2019). Socially responsible communication is important because these activities can influence the attitudes of stakeholders and others around the company.

Corporate governance must be transparent and honest in its speeches. In addition, CSR activities must be properly communicated to avoid increasing skepticism of corporate communication.

## **2. LITERATURE REVIEW**

The issue of the corporate social responsibility has been researched and analysed by many foreign and domestic authors, and remains actual. The concept of corporate social responsibility was first mentioned by Bowen (1953) in his book *Social Responsibilities of the Businessman*, and at the same time he proposed a set of specific principles for corporations that they would become socially responsible by meeting. He defined CSR as the obligations of businessmen to pursue those policies, to make those decisions, or to follow those lines of action which are desirable in terms of the objectives and values of our society. Later, the concept of the CSR became more and more popular, resulting in its use in various contexts, to the extent that its meaning became unclear and the opinions of the different experts were different. This was one of the reasons why Carrol (1979) in his three-dimensional model, probably formulated the first unified definition of corporate social responsibility, including up to four levels of responsibility – economic, legal, ethical and philanthropic. Burke and Logsdon (1996) identified five dimensions of strategic CSR which, for them, are essential for achieving the business objectives as well as for value creation: centrality, specificity, proactivity, visibility, and voluntarism. These five strategic CSR dimensions help to explain how resources and capabilities may create value for the firm.

Freeman's definition deals with the relationship between CSR and stakeholders. According to this approach, the corporation has a broader constituency and, consequently, it is responsible towards a wide group of stakeholders, which includes suppliers, customers, shareholders and the local community. In Freeman's opinion, this group includes all individuals or groups who have a legitimate interest in the activities of a firm. Currently, this approach is used by many business managers (Freeman, 1984). Smith (2001) pointed out that CSR relates to the company's obligations to its stakeholders and is influenced by corporate policies and practices. These obligations go beyond the statutory requirements and obligations of the company towards shareholders. The purpose of meeting these obligations is to minimize any damage and maximize the long-term positive impact of the company on the company. A similar view was presented by Bussard et al. (2005), according to which CSR represents a set of management practices of the company that minimize the negative and at the same time maximize the positive consequences of its behaviour on the company. In this way, the concept of corporate social responsibility has taken on a new dimension and has suddenly been open to a wider range of stakeholders.

CSR can also be seen as a voluntary integration of social and environmental aspects into the company's daily business operations and interaction with stakeholders (Chen & Gavius, 2015). Based on several previous definitions, Dahlsrud (2008) has defined five basic aspects of CSR that have been repeated in these definitions, namely environmental fields, social fields, economic fields, stakeholders and volunteering. As is apparent from the above, the main features of the CSR are the principle of volunteering, which is mentioned in definitions not only at the academic level, but also from the perspective of different organizations (Moravcikova & Gajanova, 2017). According to World Business Council for Sustainable Development (1999), CSR represents the commitment of business to contribute to sustainable economic development, working with employees, their families, the local community, and society at large to improve their quality of life.

European Commission (2001) defines CSR as a concept whereby the company integrates social and environmental concerns in their business operations and in their interactions with their stakeholders on a voluntary basis. The concept of the CSR has also been criticized by some experts. According to them, it constitutes a threat to the free market (Levitt, 1958), unjustified spending (Friedman, 1962) or the possibility of misuse to buy a good reputation (Johnson, 1971). However, despite the wide-ranging and different views of the CSR, the prevailing view is that the concept is not inherently inconsistent with profit making, while focusing on sustainable growth and development and is therefore currently a positive trend (Stonkute et al., 2018; Vetrakova et al., 2018).

Over the years, several authors have dealt with the issue of socially responsible communication. The aim of socially responsible communication is to make the CSR activities of the company visible through a variety of communication tools. According to Morsing and Schultz (2006), through socially responsible communication, companies want to report that they are ethically and socially responsible. In order to achieve the desired results, they have to involve stakeholders in this process. In particular, they draw attention to the importance of engaging stakeholders in long-term value creation, and in order to achieve this goal, a company have to develop CSR communication from a monologue to dialogue and dialogue-based relationships. According to Scholder et al. (2006), CSR communication is essential to create and maintain the desired reputation effects. McWilliams and Siegel (2011) consider socially responsible communication as an important part of successfully achieving the CSR's strategic objectives and an essential part of particular CSR activities. Luo and Bhattacharya (2009) emphasize the right timing of socially responsible communication as well as the fact that it needs to be designed and perceived as a coherent concept, since companies investing to CSR can create intangible assets in the form of brand loyalty, customer loyalty, reputation, improving sales performance and stakeholder identification. According to Wagner et al. (2009), the communication strategy for the CSR plays a key role and influences stakeholders' attitudes towards the business. Kupec (2013) designed a process that online analyses the internal information of client operations for managing of CSR consulting activities in the banking sector. According to him, the inclusion of these social activities into daily activities can also be labelled as the implementation of socially responsible behaviour in bank strategies.

Jonek-Kowalska and Zielinski (2017) have analysed the activities and communication within the frame of CSR in the banking sector from the perspective of stakeholder theory. Perez and del Bosque (2015) found out, that CSR perceptions positively impact customer identification with the banking company, emotions, satisfaction, recommendation and repurchase behaviours in both samples. However, CSR is perceived differently by customers depending on the type of banking company that implements it as well as its communication (Kliestikova et al., 2019; 33. Nica et al., 2019). Thus, its effects on customers' affective and behavioural responses are different (Belas et al., 2019; Gavurova et al., 2017; Pakurar et al., 2019).

### **3. METHODS**

The aim of this article includes providing a literature review on the issue from the perspective of several foreign and domestic authors. By using methods of description, comparison, deduction, induction, it discusses the essence of corporate social responsibility as well as socially responsible communication and also analyses its practical use in the banking sector. Based on the analysis, the benefits of using socially responsible communication strategy in the banking sector are highlighted, that includes, in particular, strengthening the company's image, increasing the brand value (Kicova & Krizanova, 2017), building customer relationships and gaining their loyalty (Kliestikova & Janoskova, 2017).

Finally, proposals are put forward for the effective implementation of socially responsible communication strategy in the banking sector. The secondary data for the analysis were obtained from annual companies reports, statistical tables and published professional publications – both in print and electronic media. General scientific methods were applied for the processing of the data. When examining and identifying the usage of the socially responsible communication strategy in the banking sector, the definitions of the approaches and concepts that are mentioned above were maintained.

#### **4. RESULTS AND DISCUSSION**

By implementing CSR principles, the company confirms its commitment to socially responsible behaviour. Applying effective CSR activities represents a challenge for most industries all around the world, making it essential for modern business. It should also be noted that a company's commitment to socially responsible behaviour becomes an important factor on which investors base their decisions. Based on this, we can see that the issue of corporate social responsibility as well as sustainability extends to sectors that at first glance do not have a significant negative impact on society and the environment, such as the financial sector (Derevianko, 2019). As part of the financial sector, banks require incorporating ethical values and corporate social responsibility principles into their marketing strategies. In the USA and Canada, and later in Western Europe, the concept of CSR became part of the management of many companies the 1950s and 1960s, and gradually expanded to all sectors, including the banking sector (Buriak et al., 2019; Myskova & Hajek, 2019). However, companies initially focused on corporate philanthropy, social security for their employees, as well as assistance to local governments and sponsorship, which in part were part of the company's PR. However, the situation in the countries of post-communist Central and Eastern Europe, including the Slovak Republic, was different due to political and economic influences than in Western Europe or the USA. Individual aspects of social responsibility were given less attention than the transition to a market economy. However, this has not prevented the CSR concept from gradually spreading to companies, mainly on their own initiative with minimal support from civil society, media and public authorities. After the Slovak economy had undergone reforms in the second half of the 1990s, the country opened up to the world, increasing the inflow of foreign investment. This has attracted large investors who have brought CSR principles from their home countries into business strategies. Socially responsible communication strategy is analysed in case of the particular Slovak bank, Slovenska sporitelna. Slovenska sporitelna has the longest tradition of saving services in Slovakia, it was established in the 19th century. In 1953, the bank became part of Czechoslovak State Savings Bank. From 1969, Slovenska sporitelna started its activity as a separate entity - Slovak State Savings Bank, state monetary institution. In 1990, Slovenska sporitelna obtained a universal bank license and extended its services within the institutional and business client segments as well. The activity of Slovenska Sporitelna on money and capital markets, in relation to securities, started when they were set up in 1991. In 2001, Slovenska sporitelna became part of the strong Erste Bank der Oesterreichischen Sparkassen AG financial group. Currently, Slovenska sporitelna is the largest commercial bank in Slovakia with a full foreign exchange license and a permit for mortgage trading. This bank has the largest share of the deposit market, has the biggest network of its own branches and issues the most bank payment cards. It provides a full range of products and services to its clients, from traditional current accounts to various kinds of passbooks, term deposits, payment systems services, loans and modern electronic banking services. The foreign activities of the bank and its clients are supported by the bank's membership of the international S.W.I.F.T. payment network, which allows payments to be sent around the world through correspondent banks. It was the first bank in Slovakia to obtain a license for the issue and acceptance of all kinds of VISA International payment cards. Currently, the bank also has a EUROPAY International and MASTERCARD

International licence. Slovenska sporitelna was ranked first in the annual TREND Magazine Award for Outstanding Business Results - Bank of the Year 2019. In 2017, it became the winner of Via Bona Slovakia (the most prestigious award in the field of philanthropy and corporate social responsibility in Slovakia) in the category of Responsible Large Company. As mentioned, Slovenska sporitelna is currently the largest commercial bank in Slovakia. The bank's CSR strategy is based on efforts to contribute to a better life, prosperity and development of the whole society in Slovakia. It helps people to live better, whether working in the core business, but also community service. According to the bank's management, being a responsible member of the community means feeling responsible for the company in which the bank operates and of which it is part. The Bank takes this into account in all its activities. CSR activities of Slovenska sporitelna are focused on social, economic as well as environmental areas. They include:

- Social banking – targeting on groups that are not usually covered by other banks, whether they are start-ups, NGOs or low-income groups – it provides them banking services, education or consulting;
- The principle of zero tolerance against corruption, fraud or any abusive practice;
- Helpfulness and friendliness to employees – creation of a friendly workplace for employees, quality work environment, benefits, managerial skills training, sport activities, above-standard health check-ups, volunteering day during working hours, massage for employees, development lectures and workshops, as well as regular special offers and much more;
- Online banking – sending bank statements and documents via email;
- Application of the principles "green banking";
- Billboard-free communication – the bank has no advertising space in public space and thus does not contribute to visual smog in public space;
- Holder of the EN ISO 14001/2015 Environmental management system certificate;
- Environmental policy and strategies – e.g. reducing electricity consumption and paper consumption, creating an environmentally friendly environment, ecological buildings, solar panels on the roofs of buildings, recycling, use of recycled materials, use of ecological means of transport or fuel, biodiversity conservation, sustainable management and use of renewable natural resources, pollution prevention and waste minimization;
- The educational environmental program for schools so called Green School;
- Support of various charity projects through Slovenska sporitelna Foundation, focused on education and increasing financial literacy – e.g. general partner of the nationwide survey Tree of the Year (Ekopolis Foundation), support of the Daphne project - Institute of Applied Ecology for the Protection of Rare Species of Plants and Animals biodiversity islands, cooperation with the Ekopolis Foundation on the informal educational project ENVIROEducation for selected secondary schools, grant program Municipalities closer to you also focused on improving the environment , grant program #mamnato - A city close to people, focused on supporting projects that will improve the lives of people in the city, village or community and so on.

The basic criterion of the analysis of socially responsible communication in Slovenska sporitelna is its division into internal and external.

1. Internal socially responsible communication in Slovenska sporitelna includes:

- Employee involvement – getting feedback through internal employee questionnaires or direct employee inquiry, implementation of the corporate volunteering concept during working hours;
- Boards, posters – with outputs from events of philanthropic-altruistic nature, e.g. photos of volunteer workers, information on the amount of money that the company provided



for charity last year, the ecological waste treatment system, socially responsible corporate strategy, and so on;

- Regular meetings of all employees;
- Training and interviewing;
- Internal press (newsletter, annual reports) – in electronic form;
- Circulars or e-mails – providing information on the news regarding the possibility of participating in organized CSR actions as well as on the implementation of the social commitment goals, not only at the Slovenska sporitelna level but within the whole bank sector;
- Internal videos and virtual publications on the CSR.

2. External socially responsible communication in Slovenska sporitelna includes:

- Advertising – socially responsible communication primarily in the Internet environment, less radio and TV;
- Sales promotion – the efficiency of its use is justified by the importance of the customer's previous own experience, not only making repeated purchases, but also influencing the purchasing behaviour, value framework and lifestyle of its surroundings using WoM;
- Personal sale – a tool of direct communication and building a long-term business relationship with stakeholders (mainly bank customers) in order to offer a service while building a long-term positive relationship that would contribute to creating the desired image of a bank as a socially responsible company;
- Public relations – press releases, press conferences, commercial articles prepared for several Slovak media, electronic and audio-visual recordings for publication in the media, the before mentioned support of various charity projects, publication of CSR reports (on a voluntary and obligatory basis);
- Direct marketing – informing stakeholders about CSR activities via SMS, e-mail, bank website, etc.;
- Modern tools of marketing communication – information about CSR activities through bank profiles on social networks (e.g. Facebook, Instagram, YouTube), influencer marketing, blogs about CSR activities of the bank.

Based on the above mentioned, we can state, that Slovenska sporitelna effectively implemented concept CSR into its business strategy and its socially responsible communication is at an excellent level, as evidenced by several awards.

## 5. CONCLUSION

The concept of CSR is a very progressive way of management, focused on long-term goals and long-term return in all industries including bank sector. CSR seeks to harmonize relationships with the stakeholders, which the company identifies precisely and undertakes activities that go beyond legal and ethical standards. A socially responsible bank does something extra voluntarily, conducts a dialogue with its stakeholders and invests in improving mutual relations. If the socially responsible bank wants to maximize the benefits resulting from its CSR activities, whether it is to improve customer relationships, strengthen its credibility and reputation, or increasing the attractivity to investors, it has to present and communicate its activities in a targeted way. Only then it will be successful and multiply the benefits of adopting the concept. The most visible benefits of efficient socially responsible communication in the banking sector include:

- Strengthening the bank's image
- Increasing the value of the bank's brand
- Gain new customers
- Building customer relationships and gaining their loyalty
- Competitive advantage
- Allow risk management – protect the bank from costly litigation and resulting damage to the brand name
- Helps increase profits – customers are willing to buy the services of a responsible bank
- Helps reduce costs – CSR certificates are widely known, increasing pressure to streamline resource use, promoting energy and materials savings
- Support for innovation
- Help banks maintain legitimacy – enhance the bank's reputation
- Enable better management of human resources
- Make investors more attractive

The issue of the socially responsible communication in the banking sector has the potential for deeper research in the future - both qualitatively and quantitatively. To obtain statistical relevance, it would be appropriate to investigate the findings of qualitative research quantitatively. A further qualitative investigation would be appropriate for expanding knowledge and comparing the impact of each tool of socially responsible communication in banking sector on the particular stakeholders.

**ACKNOWLEDGEMENT:** *This paper is a partial output of the project VEGA no. 1/0064/20: Behaviorism in a socially responsible communication strategy of enterprises*

#### LITERATURE:

1. Bhattacharya, C. B., Sen, S. (2004). Doing Better at Doing Good: When, Why and How Consumers Respond to Corporate Social Initiatives. *California Management Review*, vol. 47, nr. 1, pp. 9-24.
2. Belas, J., Kocisova, K., Gavurova, B. (2019). Determinants of Cost Efficiency: Evidence from Banking Sectors in EU Countries. *Acta Polytechnica Hungarica*, vol. 16, nr.5, pp. 101-123.
3. Bowen, H. R. (1953). *Social Responsibilities of the Businessman*. Iowa City: University of Iowa Press, Iowa.
4. Buriak, A., Voznakova, I., Sulkowska, J., Kryvysh, Y. (2019). Social trust and institutional (bank) trust: Empirical evidence of interaction. *Economics and Sociology*, vol. 12, nr. 4.
5. Burke, L., Logsdon, J. M. (1996). How corporate social responsibility pays off. *Long Range Planning*, vol. 29, pp. 495-502.
6. Bussard, A. et al. (2005). *Corporate social responsibility. Overview of basic principles and examples*. Bratislava: Integra Foundation.
7. Carroll, A. B. (1979). A three-dimensional conceptual model of corporate performance. *Academy of management review*, vol. 4, nr.4, pp. 497-505.
8. Chen, E., Gavius, I. (2015). Does CSR have Different Value Implications for Different Shareholders? *Finance Research Letters*, vol. 14, pp. 29-35.
9. Dahlsrud, A. (2008). How Corporate Social Responsibility is defined: An Analysis of 37 Definitions. *Corporate Social Responsibility and Environmental Management*, vol. 15, pp. 1-13.
10. Derevianko, O. (2019). Reputation stability vs anti-crisis sustainability: under what circumstances will innovations, media activities and CSR be in higher demand? *Oeconomia Copernicana*, vol. 10, nr. 3, pp. 511-536.

11. European Commission (2001). Green paper and related documents. Retrieved 15.03.2020 from <https://ec.europa.eu/environment/ipp/2001developments.htm>
12. Freeman, R. E. (1984). *Strategic Management: A Stakeholder Approach*. Pitman, Boston.
13. Friedman, M. (1962). *Capitalism and freedom*. USA: University of Chicago Press.
14. Gavurova, B., Belas, J., Kocisova, K., Kliestik, T. (2017). Comparison of selected methods for performance evaluation of Czech and Slovak commercial banks. *Journal of Business Economics and Management*, vol. 18, nr. 5, pp. 852-876.
15. Gorgenyi Hegyes, E., Fekete-Farkas, M. (2019). Internal CSR as a Strategic Management Tool in Reduction of Labour Shortages. *Polish Journal of Management Studies*, vol. 19, nr. 2, pp. 167-181.
16. Gregova, E., Kramarova, K., Dengov, V. V. (2016). Significance of the Corporate Social Responsibility at National and International Level. *Proceedings of the International Conference on Information and Business Management (ISSGBM-IB 2016)*, vol. 61, pp. 9-15.
17. Hitka, M., Lorincova, S., Lizbetinova, L. (2017). Comparison of Using Social Networks for Seeking Employment in Italy and Slovakia. *Proceedings of the 30th International Business, Information, Management, Association Conference - Vision 2020: Sustainable Economic Development, Innovation Management, and Global Growth*, pp. 1579-1586.
18. Johnson, H. L. (1971). *Business in Contemporary Society: Framework and Issues*. Belmont: Wadsworth Publishing Co., Inc.
19. Jonek-Kowalska, I., Zielinski, M. (2017). CSR Activities in the Banking Sector in Poland. *Proceedings of the 29th International Business, Information, Management, Association Conference – Sustainable Economic Growth, Education Excellence, and Innovation Management through Vision 2020*, pp. 1294-1304.
20. Kicova, E., Krizanova, A. (2017). Building a sustainable brand. *Springer Proceedings in Business and Economics: Advances in Applied Economic Research*, pp. 367-379.
21. Kliestikova, J., Janoskova, K. (2017). Branding with understanding: how national profile of consumer influences brand value perception. *Marketing and management of innovations*, no. 3, pp. 149-157.
22. Kliestikova, J., Kovacova, M., Krizanova A. (2019). Brand value sources: Case study of bank brands in Slovak republic. *Proceedings of 39th international scientific conference Economic and Social Development*, pp. 361-368.
23. Krizanova, A., Gajanova, L. (2016). The importance of CSR implementation. *Proceedings of the CBU International Conference on Innovations in Science and Education (CBUIC)*, pp. 515-519.
24. Kupec, V. (2013). CSR application in online banking. *Proceedings of the International Scientific Conference on Marketing identity: Design that Sells*, pp. 371-381.
25. Levitt, T. (1958). The Dangers of Social Responsibility. *Harvard Business Review*, vol. 36, nr. 5, pp. 41-50.
26. Lizbetinova, L., Starchon, P., Lorincova, S., Weberova, D., Prusa, P. (2019). Application of Cluster Analysis in Marketing Communications in Small and Medium-Sized Enterprises: An Empirical Study in the Slovak Republic. *Sustainability*, vol. 11, nr. 8, art. no. 2302.
27. Luo, X., Bhattacharya, C. B. (2009). The Debate over Doing Good: Corporate Social Performance, Strategic Marketing Levers, and Firm-Idiosyncratic Risk. *Journal of Marketing*, vol. 73, pp. 198-213.
28. McWilliams, A., Siegel, D. (2001). Corporate Social Responsibility: A Theory of the Firm Perspective. *The Academy of Management Review*, vol. 26, pp. 117-127.
29. Moravcikova, D., Krizanova, A., Kliestikova, A., Rypakova, M. (2017). Green Marketing as the Source of the Competitive Advantage of the Business. *Sustainability*, vol. 9, no. 12, art. no. 2218.

30. Moravcikova, K., Gajanova, L. (2017). Attitude of Customers to Socially Responsible Products. *Springer Proceedings in Business and Economics: Advances in Applied Economic Research*, pp. 599-606.
31. Morsing, M., Schultz, M. (2008). Corporate social responsibility communication: Stakeholder information, response and involvement strategies. *Business Ethics: A European Review*, vol. 15, pp. 324-338.
32. Myskova, R., Hajek, P. (2019). Relationship between corporate social responsibility in corporate annual reports and financial performance of the US companies. *Journal of International Studies*, vol. 12, nr. 1.
33. Nica, E., Miklencicova, R., Kicova, E. (2019). Artificial Intelligence-supported Workplace Decisions: Big Data Algorithmic Analytics, Sensory and Tracking Technologies, and Metabolism Monitors. *Psychosociological Issues in Human Resource Management*, vol. 7, nr. 2, pp. 31-36.
34. Pakurar, M., Haddad, H., Nagy, J., Popp, J., Olah, J. (2019). The Service Quality Dimensions that Affect Customer Satisfaction in the Jordanian Banking Sector. *Sustainability*, vol. 11, nr. 4, art. no. 1113.
35. Perez, A., del Bosque, I. R. (2015). Customer responses to the CSR of banking companies. *Journal of Product and Brand Management*, vol. 24, nr. 5, pp. 481-493.
36. Reicher, Z. R. (2019). Opportunities for small and medium sized enterprises in the field of corporate social responsibility, *Ekonomicko-manazerske Spektrum*, vol. 13, nr. 1, pp. 26-37.
37. Scholder, E. P., Webb, D. J., Mohr, L. A. (2006). Building Corporate Associations: Consumer Attributions for Corporate Socially Responsible Programs. *Journal of the Academy of Marketing Science*, vol. 34, nr. 2, pp. 147-157.
38. Smith, N. C. (2001). Changes in corporate practices in response to public interest advocacy and actions. *Handbook of Marketing and Society*. Thousand Oaks, CA: Sage, pp. 140-161.
39. Sroka, W., Szanto, R. (2018). Corporate Social Responsibility and Business Ethics in Controversial Sectors: Analysis of Research Results. *Journal of Entrepreneurship, Management and Innovation*, vol. 14, nr. 3, pp. 111-126.
40. Stonkute, E., Vveinhardt, J., Sroka, W. (2018). Training the CSR Sensitive Mind-Set: The Integration of CSR into the Training of Business Administration Professionals. *Sustainability*, vol. 10, nr. 3, art. no. 754.
41. Vetrakova, M., Hitka, M., Potkany, M., Lorincova, S., Smerek, L. (2018). Corporate Sustainability in the Process of Employee Recruitment through Social Networks in Conditions of Slovak Small and Medium Enterprises. *Sustainability*, vol. 10, nr. 5, art. no. 1670.
42. Wagner, T., Lutz, R. J., Weitz, B. A. (2009). Corporate Hypocrisy: Overcoming the Threat of Inconsistent Corporate Social Responsibility Perceptions. *Journal of Marketing*, vol. 73, pp. 77-91.
43. WBCSD. (1999). *Corporate social responsibility: Meeting changing expectations*. Geneva: World Business Council for Sustainable Development.

# HOW MOBILE BANKING IN THE DIGITAL ERA CAN RESHAPE THE BANKING LANDSCAPE: A LITERATURE REVIEW

**Maria Cristina Quirici**

*University of Pisa, Italy*

*Department of Economics and Management*

*Pisa, C. Ridolfi str. 10, 56124, Italy*

*maria.cristina.quirici@unipi.it*

## **ABSTRACT**

*The impacts of FinTechs (Financial Technology) and digitalization on the financial sector, and on the banking industry in particular, are more and more consistent, almost disruptive. Progress in mobile device development, with the actual diffusion of smartphones, with a cheaper and widely-spread Internet have led to a growing number of Mobile Banking users all over the world. The present research wants to analyze the role of Mobile Banking in the present financial digital framework according to the banking perspective. To reach this aim the paper starts with a literature review regarding the significance of Mobile Banking, being difficult to find a relative univocal definition in literature, with no consensus for example in its definition and role in developed and developing countries. Then the paper investigates and explores the various channels through which Mobile Money Services affect bank performances. The analysis, based on a review of the relative existing literature, is able to point out that the actual disruptive changes in mobile financial services and payments can represent also a great opportunity for banks to reduce their marginal costs and to increase their productivity, giving them the possibility to leverage innovative and less costly business models too. The paper in its final part indicates also some topics for further researches.*

**Keywords:** *Banking Performance, Digitalization, FinTechs, Mobile Banking, Mobile Payments*

## **1. INTRODUCTION**

The introduction and successive growth of Internet, more and more cheaper and widely-spread, and of mobile technologies have transformed many branches of industries, including the banking one, changing markets and ways of competition. Technology-driven innovation in financial services – known as *FinTech*, resulting from *Financial Technology* – is increasingly reshaping the financial landscape, and the banking one in a particular way, as never before (Asongu and Nwachukwu, 2018; Sironi, 2016; Disse and Sommer, 2020; Ky *et al.* 2019). Considering that every innovation creates changes and these changes translates into risks, it's evident that FinTech can create the risk to disrupt the existing banking model. And mobile banking, combined with Internet diffusion, is today one of the biggest technological change agent, being among the latest in a series of recent mobile technological wonders. But all these important changes can represent also an extraordinary way to progress and to reach new and better frontiers for banks. In other terms, the deep development of modern technologies can represent one of the biggest allies in order to redirect and to redesign banking activities. In fact, banks can use these technological innovations to create new communication channels to reach every kind of client, also the less accessible ones. In their evolution from phone banking, through internet banking until mobile banking, banks have had a primary goal: to simplify their business model, going out of a rather conservative way of doing banking, offering new and less expensive distribution channels for their services. Consequently, it is important to monitor mobile banking, within the FinTech phenomenon, since, according to information system experts, it is surely a key for banking innovative activities in the future. To analyse the role of mobile banking in the new digitalized framework and to investigate how it can represent an instrument to reshape the banking landscape, it's necessary to start with a literature review

concerning the same definition of mobile banking. After this, the work continues with an analysis, based on a review of the relative existing literature, first of the impact of Fintech and digitalization on the banking industry, and then of the various channels through which Mobile Money Services, that of FinTech are a considerable part, affect bank performances, considering in a particular way the opportunities for banks deriving from the development of these mobile services. Some conclusive considerations close the work, with the indications of some elements for further researches.

## 2. MOBILE BANKING DEFINITIONS: A LITERATURE REVIEW

Mobile banking enables users to have all financial resources “in their hands”, via mobile devices, mobile phones and personal digital assistants. Although automated teller machine (ATM), telephone, and Internet banking offer effective delivery channels for traditional banking products, considering the newest delivery channel established by retail and microfinance banks in many developed and developing countries, mobile banking is likely to have significant effects on the market (Ashta and Biot-Paquerot, 2018). The evolution of 3G phones, smartphones, and new 4G/5G technologies has surely widen the spectra of new and improved models of mobile banking. Smartphones and tablets are becoming new hardware devices present in everyday life, which will drive a bigger and faster supply of mobile solutions (DBResearch, 2012). In particular, the expanded use of smartphones has increased demand for mobile banking services, prompting many more banks, microfinance institutions, software houses and service providers to offer these innovative services together with new sets of products and applications, designed to reach more and more clients (including unbanked populations), improve customer retention, enhance operational efficiency, increase market share, providing new employment opportunities too (Dupas *et al.*, 2018). Academic research has started to analyze the role of m-banking in today’s economy almost recently but, according to the findings indicated by Shaikh and Karjaluoto, who proposed a literature review on mobile banking adoption, “*existing research is fragmented, constituted by various theoretical frameworks, with relatively small sample sizes (average N=365) drawn from both developed and developing countries*” (Shaikh and Karjaluoto, 2015, p. 14) Moreover, according to the same authors, “*the extant literature appears limited by its narrow focus on SMS banking in developing countries (...)*” (*Ibidem*, p.1). It’s necessary to underline that there is no consensus in the definition of mobile banking between North and South. In industrialized (or developed) countries, mobile banking refers to an extension of banking and financial services provided on mobile phones by financial institutions (Lin, 2011). By contrast, in developing countries, mobile banking is a broader form of banking that includes, for example, payment services (m-payments), transfer of funds, and deposits (Fall *et al.*, 2020; Jack and Suri, 2014; Suri and Jack, 2016). The difficult in finding a univocal definition of mobile banking in literature derives also from the fact that researchers have used various terms to refer to mobile banking: branchless banking (Ivatury and Mas, 2008); m-payments, m-transfers, m-finance (Huili *et al.*, 2013); pocket banking (Amin and Ramayah, 2010). Some authors identify the difference between mobile banking (or m-banking) and mobile payment (or m-payment) and argue that, if a bank is not directly involved in the instrumental gratification of a service offered, it can be called “m-payment” and examples of such services include payments through overhead-priced SMS, prepaid account loading, or a charge made to the subscriber’s account (e.g., credit card or invoice based payment mechanism). (Cruz *et al.*, 2010). According to Ndiwalana and Popov (2016), m-payments are financial transactions actuated by users through the help of mobile devices, in our context the growing number of mobile phones. M-payments can be considered a subset of m-banking, which refers to accessing various banking services via mobile devices, so m-payments may be one of the services provided by a financial institution. On the other hand, mobile commerce (or m-commerce) refers to monetary transactions conducted and

facilitated via mobile networks. All the above services can be considered subsets of their electronic counterparts: m-payments are a subset of electronic payments (e-payments), m-banking is a subset of electronic banking (e-banking) and m-commerce is a subset of electronic commerce (e-commerce). The distinction is their reliance on mobility. Being an important component of e-banking, m-banking usually constitutes an alternative delivery channel (ADC) for financial transactions (Shaikh and Karjaluoto, 2015). According to Bank of Uganda, instead, *“Mobile money, along with “mobile banking”, pertains to the larger area of “mobile financial services”. “Mobile money” is e-money available to a user to conduct transactions through a mobile phone. The mobile money wallet/mobile money account is an electronic money (e-money) account which receives electronic value either after the account holder deposits cash via an agent or receives a payment/remittance from elsewhere. “Mobile banking”, on the other hand, refers to the use of a mobile phone to perform transactions on one’s account in a licensed institution (including balance inquiries, mini-statements, statements and cheque books requisitions, forex rates enquiries and funds transfer to other nominated bank accounts). The term “mobile financial services” encompasses both “mobile money” and “mobile banking” (Bank of Uganda 2017, p.1).*

Some studies (Akturan and Tezcan, 2012; Masrek *et al.*, 2012) cite m-banking as an innovative communication channel that allows the customer to interact with a bank through a portable device. According to Tomić and Stojanović (2018) *“M-banking is one of the application that came out from mobile commerce (M-commerce). It is a channel through which banks interact with clients by using mobile devices in the most simplified form. Banks use m-banking, i.e. SMS services to send clients updated information”*. At the same time, according to these authors, the most adequate definition of mobile banking has been given by Luo *et al.* (2010): *“Mobile banking is an innovative method to access to banking services through a channel, whereby the users interact with the bank via mobile devices (e.g. a mobile phone or a personal digital assistant)”*. In literature, also other researchers define m-banking as an application of m-commerce, that enables customers to access bank accounts through mobile devices to conduct transactions, such as checking account status, transferring money, making payments, or selling stocks (Alafeef *et al.*, 2012).

However, the dynamic markets for mobile devices and mobile banking suggest the need for a definition able to capture recent advances in the field. Previous definitions have not, for example, explicitly stated which mobile devices may be qualified for m-banking use: accessing banking services from a laptop should not be considered m-banking, because laptops are aligned with the online/Internet banking category rather than with m-banking. According to Shaikh and Karjaluoto (2015), mobile banking can be defined as *“A product or service offered by a bank or a microfinance institute (bank-led model) or MNO (non-bank-led model) for conducting financial and non-financial transactions using a mobile device, namely a mobile phone, smartphone, or tablet”*. In fact, retail and microfinance banks, located in both developed and developing countries, typically offer four points of access to m-banking services: (1) mobile applications, that can be downloaded to a smartphone; (2) mobile browsers, that can be used with any mobile or smartphone having a Web browser; (3) applications, that can be downloaded to a tablet; (4) short messaging services (SMS), that provide notifications of account information (Shaikh and Karjaluoto 2015, p. 5). In the direction of a network perspective, Fall *et al.* (2020) point out that mobile banking can be defined *“as a platform accessed by a mobile phone to make payments, transfer funds, make deposits (withdrawals are unnecessary), and borrow money (overdraft allowed)”*.

### 3. FINTECH AND DIGITALIZATION: THEIR IMPACT ON BANKING INDUSTRY

Mobile banking is surely a considerable part of FinTech, a complex phenomenon that can be defined in various ways. In literature, it's relevant the definition given by the Financial Stability Board, that adopted a rather broad definition of FinTech due to the rapidly and fluidity of its developments, considering it as “*technologically-enabled financial innovation that could result in new business models, applications, processes, or products with an associated material effect on financial markets and institutions and the provision of financial services*” (Financial Stability Board, 2017, p. 7). The terminology “FinTech” can be alternatively used for various financial technologies and for their providers: in the first meaning, the FinTech ecosystem features a variety of business propositions which can span from peer-to-peer lending to digital payments (as mobile payments), or Big Data analytics, or blockchain technology; in the second one, FinTechs are all start-up companies which appeared between 2008 and 2010 particularly in the USA, but fast spreading out to the East Coast, Europe, Hong Kong, Singapore, Australia and much part of Asia (Sironi, 2016, p. 5). Yet, according to Sironi, looking at the business philosophy and aspirations of their founders, “FinTechs are a global phenomenon, born at the intersection between financial firms and technology providers, attempting to leverage on digital technology and advanced analytics to unbundle financial services and harness economies of scale by targeting long-tail consumers” (Sironi, 2016, p. 5). Instead, FinTech can be described as “*the employment of information technology to provide innovative and improved financial services*” (Disse and Sommer, 2020, p. 18).

Clearly, digitalization plays in this contest a key role, because just digital tools allow the creation of captive customer experiences as weapon to tear down the barriers to entry in financial services, fostering borderless competition against established institutions (Anagnostopoulos, 2018; Basel Committee on Banking Supervision, 2018). *FinTech* innovations can disrupt existing industry structures and boundaries but, at the same time, they can democratize access to financial services, causing significant privacy, regulatory and law enforcement challenges (Cabò-Valverde, 2017, p. 134). In fact, the structural change in technology happens in parallel to competitive changes in the banking industry. So significant welfare gains from improvement in financial services are technologically feasible but unlikely to happen without the entry of new firms in the financial sector. This complex combination of technological and competitive changes can be understood only if the features of the new financial activities are properly addressed. Many of the new services and activities related to digitalization and FinTech, often provided by multi-sided platforms, cannot be observed through the lens of the standard/traditional approach. So, regulators and supervisors have to monitor these technological challenges and to develop appropriate financial stability policies, taking into account the new ways of operating of these platforms. (Cabò-Valverde, 2017). In other terms, a new financial intermediation framework is growing, with huge amounts of information processing (*big data*) and new delivery channels, to improve the access to credit or other services from different types of clients. A new business, where the distance between households, small firms and their lenders will be increasing, as communicating in more impersonal ways (Sy *et al.*, 2019). However, banks will interact with new players into this new FinTech business in various ways, from fierce competition to cooperation. Regulators will need to check whether regulation offers a level-playing field for such interaction and the necessary tools to preserve financial stability. Therefore, the implications of digitalization in the financial sector, and in the banking one in particular, seem to be enormous. The locality and physical reality of financial services have been transformed, the same methods and customer expectations of delivering them have profoundly changed and they are continuing to change.: in developed countries, digital distribution of data and networked systems driven by convenience and cost reduction are prevalent (De Almeida *et al.*, 2018), while in developing



countries there has been increasing access to inclusion in financial services (Wieser *et al.*, 2019). In other terms, consumers will continue to need financial services, but they will embrace more decentralized solutions, as it is happening also in other industries. The sharing economy is foreseen to become embedded in financial products, including peer-to-peer lending, cashless and payment integrated services (such as Uber and Amazon). The World Energy Forum and Deloitte identified 11 disrupting clusters of innovations related to digitalization and these innovations will exert pressure on the traditional financial services model in the near future (McWaters, 2015). Traditionally, banking systems were largely impenetrable for new entrants. With the digital transformation, small and agile new suppliers have appeared in large numbers, and incumbents are losing leverage unless they adapt to the new financial ecosystem (McWaters, 2016). FinTech disruptors are usually fast-moving, start-up companies that generally focus on a particular innovative technology or process. They have been invading various services, from mobile payments to insurance, and have more than tripled annual global investments in the last five years. The banking industry has recently seen the introduction of numerous online only or direct banks (N26), many of which offer worldwide access. Data and analysis are becoming key to revenues and profitability. Customer intelligence based on *big data*, but then translated to tailored services, is predicted to shape the future of service requirements. Financial services and technology companies more and more will use artificial intelligence to explore social and emotional intelligence, natural language processing, logical reasoning, pattern assessment, sensors, or mobility, and more. The services created are expected to growth, supplying a more personalized treatment (TWI2050-The World in 2050, 2019). The current transformations of infrastructure will become the norm. Many banks already use cloud-based software-as-a-service (SaaS) applications for non-core processes, but shortly these will be the main (perhaps only) platforms for all business activities. On the customer side, mobile and online services will become the norm. In light of this, cyber-security is becoming a critical threat to be overcome. So, it's possible to point out that online banking has won its place in the traditional bank transactions sector. In fact, digital innovations provides opportunities for banks to enhance their customer-interactions, improve their decision-making, and implement new business models in a more cost-effective and innovative way. Transactions are easily done by personal computers from home or office. Real-time transaction monitoring enables users to track their money flow and driving from one part of a town to another becomes obsolete, as well as waiting in bank queues. Transactions are fast and easily done, around the clock, from anywhere in the world. These activities are more and more important for people who want to get information on their bank account or make a transaction as soon as possible. Rapid development of mobile technologies enables clients to do these bank operations from their mobile phones. Therefore, mobile banking “go” towards clients’ growing needs for more convenient and easier managing of their bank accounts and transactions, in a continuous progress from simple bank account checking to today’s mobile on-the-spot payments in stores.

#### **4. HOW MOBILE FINANCIAL SERVICES CAN REPRESENT AN OPPORTUNITY FOR BANKS**

Mobile money technology allows users to conduct financial operations through mobile networks where cash-in cash-out services are provided by small business outlets better known as agents. Although mobile network operators are the most active actors, banks play a crucial role in mobile money provision. Specifically, to launch mobile money services, mobile network operators have to build partnership with banks or other financial institutions having a banking license (Aron 2017). In this case, banks play the role of custodians for mobile money users by holding a “trust” or “escrow” account deposits that match the full extent of e-money in the name of mobile network operators. Banks can use these additional funds to increase their lending and this is not different from the way banks use ordinary deposits. Bank involvement in the mobile

money scheme includes simply holding a trust/escrow account (passive), building partnership to launch mobile money services (active), or both. To exploit other potential benefits associated with mobile money, some banks build partnership with Mobile Network Operators (MNOs) to increase the number of their ATM users: these interest and fee-generating activities constitute new sources of income that may potentially enhance bank profitability. In addition, banks can leverage mobile money platforms to reach more people in traditionally underserved areas at much lower cost. And being bank presence often limited to urban or highly populated areas, MNOs' extensive network may enhance bank efficiency in traditionally underserved areas at much lower cost (Ky et al, 2019, p. 6-7). In fact, if traditionally, banks provide cash-in/cash-out services via ATMs and bank branches, these solutions are too expensive to set up in markets that have low-income or low-density populations. Therefore, bank-MNO partnership in mobile money provision may enable banks to leverage mobile money agent networks to reach those areas with limited population size or economic activities, catering to new segments of customers and so diversifying further their income streams. In a similar vein, banks' partnership with MNOs may allow customers to perform their banking transactions without visiting banks' agencies. Exploring channels through which mobile money affects bank performance, it's possible to find that improved access to retail deposits and income diversification are possible candidates (Ky *et al.*, 2019). In terms of bank stability, the literature purports that financial technology can potentially strengthen financial stability by fostering financial inclusion, increasing diversification and transparency as well as allowing better risk assessment. According to Ahamed and Mallick (2019), financial inclusion improves financial stability by accessing cheap retail deposits from a large clientele base, reducing financing constraints of SMEs and mitigating the post-lending moral hazard. Also Ky *et al.*, considering the results of their analysis to know whether mobile money adoption enhances or worsens bank performance, "*show that enhanced income diversification and broadened access to deposits are possible channels through which banks involved in mobile money improve their performance. Overall, our finding highlight the bright side of cooperation between banks and mobile network operators in the provision of mobile money*" (Ky *et al.*, 2019, p. 1). An other factor that equally matters when it's investigated the potential impact of m-banking adoption on firm performance is bank size. According to Ky *et al.* cited analysis, small banks involved in mobile money show a strong association with both their profitability and efficiency in relation to their degree of involvement in a partnership with an MNO. These results are consistent with those of Ahamed and Mallick (2019), who notice that for small banks the length of involvement in mobile money does not matter, being sufficient this kind of involvement to realize an improvement in bank performance. Scott *et al.* (2017), then, show that the effect of technological innovations on profitability are higher on small banks than on larger ones and this because the former can adapt faster to them compared to the second ones, that may be sluggish to respond due to their stable market position and legacy systems. According to these authors, the positive relationship shown between banks' involvement in mobile money and their performance is expected to be more pronounced for banks with low retail deposit funding or low income diversification. The failure of the experience in Kenya of M-Kesho (launched in March 2010) vs. the spectacular success of its successor M-Shwari (launched in November 2012) can illustrate how decisive the sizes of the bank and MNOs involved in a partnership might be. In fact, M-Kesho and M-Shwari are digital credit products similar in every aspect except that Safaricom partnered with the largest bank in Kenya (Equity Bank) to launch the former, while for the later, the partner, CBA bank, was a small largely-unknown bank. A frequently cited reason behind the failure of M-Kesho mobile money service is that Equity Bank and Safaricom perceived each other as main competitors and failed to define the partnership in a way that satisfied both companies. This phenomenon has propelled some to ask whether cooperation between equals in this area was even desirable (Cook and McKay, 2017). Thanks to an increased use of mobile banking, banks

have transferred certain aspects of their business from branches, that were a traditional form of the bank-client interaction, and can offer cheaper and more affordable services, due to their lower costs (of human resources and offices). If all these advantages have led to a pronounced increasing trend of the number of users of m-banking, it's necessary to point out that the costs per transaction are lower not only for the clients, but also for the bank: KPMG (2015), in its cost analysis, shows transactions cost 43 times more when made in the bank than when made through distribution channels of mobile banking. Consistent with the very notion that at the core of FinTech is the use of technology to provide new and improved financial services, mobile money technology allows banks to offer to their clients financial services - such as money transfers, payments, savings, insurance and digital credit - cheaper and easier, saving their own cost (Ky et al., 2019). *“Over the last decade, mobile money has been disrupting traditional financial services and transforming the lives of hundreds of millions of people across developing countries. Today, with over \$1.3 billion a day processed by over 866 million registered accounts in 90 countries, mobile money has evolved into a broader payments platform that provides access to life-enhancing services, such as healthcare, education, employment, transportation and social protection. At a macro level, mobile money fuels economic growth by facilitating savings and investments, creates employment, drives business productivity and entrepreneurship, helps formalise the economy and provides stability during economic downturns. Mobile money is a key driver of socio-economic growth and is becoming a gateway to the digital economy. As national economies become increasingly dependent on digital technology, the power of mobile money to harness digital finance for sustainable development is strengthening”* (GSMA 2019). The mobile industry is becoming an instrument to achieve the Sustainable Development Goals (SDGs) by UN 2030 Agenda, connecting more than five billion individuals around the globe, providing access to essential communications and life-enhancing services and transforming business models across industries and societies. This is an element for further researches, besides the necessary regulatory and corporate governance implications connected to mobile banking diffusion or the consideration of the cyber-security in mobile payments too.

## 5. CONCLUSION

Today, mobile money is set to become the backbone of payments in the digital economy, facilitating platform solutions and driving innovation and economic growth (UNCTAD, 2019). Mobile money is positioned to be one of the leading forces of digital finance in order to achieve the SDGs. To harness this power, partnerships and cross-sector collaborations with other stakeholders are required (United Nations Secretary-General's Task Force on Digital Financing of the SDGs, 2019). These elements can have positive effects on banks, becoming, in their disruptive force, a great opportunity to seize. Besides creating an enabling regulatory environment, there is the need to experiment different business models to identify the most appropriate one that can accommodate all the multiple players, competitors from the same sector. Finally, it's possible to share Cabò-Valverde's conclusions on the possible impacts of Digitalization and FinTechs, and of m-banking too, on banking activities:

*“i) The digitalization change has been around for decades but today, its impact and the speed of diffusion and change seem unprecedented. In line with other industries, this is transforming the competitive structure of the banking sector, with new entrants from the FinTech industry. It also implies a revolution for bank delivery channels and information processing systems, and change in the jobs and skills that are required in financial services. From an academic perspective, understanding the economics of banking currently requires a shift from the standard buyer-seller model of standard industrial organization to models based on network externalities and multi-sided platforms with several related prices and cross-subsidies;*

ii) *Digitalization and FinTech are also an opportunity to reduce marginal costs and increase productivity in financial services. However, there are also financial stability concerns associated with these processes as they imply a massive accumulation of intangible capital which is not always appropriately valued in capital markets, and they also blur the industry boundaries and create significant privacy, regulatory and law enforcement challenges.*

iii) *Giving its systemic nature, the new activities and players in the financial sector cannot be regulated (or unregulated) the same way that other industries are enforcing regulation (e.g. taxi cab industry, social media etc.). One potential solution would be to regulate each innovation according to its specialization. That is, regulating activities rather than the players.*

iv) *Another important challenge for regulators is to ensure a level playing field between bank and non-bank providers, as well as an adequate level of control and oversight over them. There have been some regulatory initiatives in this direction – particularly in Europe – but they are still far from ensuring that level-playing field” (Cabò-Valverde, 2017).*

**ACKNOWLEDGEMENT:** *I want to thank sincerely the referees of ESD Conference of Aveiro 2020 for their useful indications regarding this paper.*

#### **LITERATURE:**

1. Ahamed, M.M., Mallick, S.K. (2019). Is financial inclusion good for bank stability? International evidence. *Journal Economic Behaviour Organization*, 157, 403–427. <https://doi.org/10.1016/j.jebo.2017.07.027>.
2. Akturan, U., Tezcan, N. (2012). Mobile banking adoption of the youth market: Perceptions and Intentions. *Marketing Intelligence & Planning*, 30(4), 444-459.
3. Alafeef, M., Singh, D., Ahmad, K. (2012). The influence of demographic factors and user interface on mobile banking adoption: A review, *Journal of Applied Sciences*, 12(20), 2082 - 2090.
4. Amin, H., Ramayah, T. (2010). SMS banking: explaining the effects of attitude, social norms and perceived security and privacy. *The Electronic Journal on Information Systems in Developing Countries*, 41(2), 1–15.
5. Anagnostopoulos, I. (2018). Fintech and regtech: Impact on regulators and banks. *Journal of Economic Business*, 100, 7–25. <https://doi.org/10.1016/j.jeconbus.2018.07.003>.
6. Ashta A. - G. Biot-Paquerot (2018), Fintech evolution: Strategic value management issues in a fast changing industry, in *Strategic Change*, 27(4): 301-311
7. Asongu S.A. and J. Nwachukwu (2018). Recent Finance advances in information technology for inclusive development: a systematic review. <https://mpira.ub.uni-muenchen.de/91531>.
8. Bank of Uganda (2013). Mobile Money Guidelines 2013.
9. Basel Committee on Banking Supervision (2018). *Sound Practices: Implications of fintech developments for Banks and Bank Supervisors*. Bank International Settlements, Basel.
10. Cabò-Valverde S. (2017). The Impact on Digitalization on Banking and Financial Stability. *Journal of Financial Management Markets and Institutions*, 5(1): 133-140.
11. Cook W., McKay C. (2017). Banking in the M-PESA age: lessons from Kenya, *Working Paper Washington D.C.*, CGAP.
12. Cruz, P., Neto, L.B.F., Muñoz-Gallego, P., Laukkanen, T. (2010). Mobile banking rollout in emerging markets: evidence from Brazil, *International Journal of Bank Marketing*, 28(5): 342-371.
13. De Almeida P., Fazendeiro P., Inácio P.R. (2018). Societal risks of the end of physical cash. *Futures*, 104: 47–60.

14. DBResearch (2012), *Homo biometricus. Biometric recognition systems and mobile internet services*, Vol. *Current Issues*, Deutsche Bank, Frankfurt am Main.
15. Disse, S., Sommer, C. (2020), *Digitalisation and its Impact on SME Finance in Sub-Saharan Africa. Reviewing the Hype and Actual Developments*, Discussion Paper n. 4, Bonn: German Development Institute (D.I.E).
16. Dupas, P., Karlan, D., Robinson, J., Ubfal, D. (2018). Banking the Unbanked? Evidence from three countries. *American Economic Journal: Applied Economics*, 10 (2): 257-297.
17. Fall F.S, Orozco, L., Akim, Al-M. (2020). Adoption and use of mobile banking by low-income individuals in Senegal. *Review of Development Economics*, Wiley, 24(2): 569-588.
18. GSMA (2019), *Harnessing the Power of Mobile Money to achieve the Sustainable Development Goals*, GSMA Report, London (UK).
19. Huili, Y., Shanzhi, L., Yinghui, Y. (2013). A study of user adoption factors of mobile banking services based on the trust and distrust perspective. *International Business and Management*, 6(2): 9–14.
20. Ivatury, G., Mas, I. (2008). The early experience with branchless banking. *CGAP Focus Note*, n. 46. Available at <http://ssrn.com/abstract=1655257> .
21. Jack, W., Suri, T. (2014). Risk Sharing and Transactions costs: Evidence from Kenya's Households Welfare: Panel Evidence from Rural Uganda, *World Development*, 79: 127-137.
22. Ky, S., Rugemintwari, C., Sauviat, A. (2019), *Is Fintech good for bank performance? The case of mobile money in the East African Community*, hal-02155077, in <https://hal.archives-ouvertes.fr/hal-02155077>.
23. KPMG (2015). *Mobile Banking Report 2015*. <https://www.kpmg.com>
24. Lin, H.F. (2011). An empirical investigation of mobile banking adoption: The effect of innovation attributes and knowledge-based trust. *International Journal of Information Management*, 31(3): 252–260.
25. Luo, X., Li, H., Zhang, J., Shim, J.P. (2010). Examining multi-dimensional trust and multifaceted risk in initial acceptance of emerging technologies: An empirical study of mobile banking services. *Decision Support Systems*, 49(2): 222–234.
26. Masrek, M.N., Omar, N., Uzir, N.A., Khairuddin, I.E. (2012). The impact of technology trust on mobile banking utilization. *Science Series Data Report*, 4(12): 27–36.
27. McWaters, J. (2015). The Future of Financial Services. How Disruptive Innovations Are Reshaping the Way Financial Services Are Structured, Provisioned and Consumed. *World Economic Forum*.
28. McWaters, J. (2016). The Future of Financial Infrastructure. *World Economic Forum*.
29. NDIWALANA A. and O. POPOV (2016), *Mobile Payments: a comparison between Philippine and Ugandan context*, in <https://www.researchgate.net/publication/228846415> .
30. Scott, S.V., Reenen, J. Van, Zachariadis, M. (2017). The long-term effect of digital innovation on bank performance: An empirical study of SWIFT adoption in financial services. *Res. Policy*, 46: 984–1004. <https://doi.org/10.1016/j.respol.2017.03.010>.
31. Shaikh, A., Karjaluo, H. (2015). Mobile banking adoption: a literature review. *Telematics and Informatics*, 32 (1). doi:10.1016/j.tele.2014.05.003.
32. Sironi P. (2016), *FinTech Innovation. From Robo-Advisors to Goal Based Investing and Gamification*, The Wiley Finance Series, West Sussex, UK, Wiley.
33. Sy, A.N.R., Maino, R., Massara, A., Perez-Saiz, H., Sharma, P. (2019). FinTech in Sub-Saharan African Countries: a Game Changer?, *IMF, Department Paper*. 19/04.
34. Suri, T., Jack, W. (2016). The Long-Run Poverty and Gender Impacts of Mobile Money. *Science*, 354(6317): 1288-1292.
35. The Financial Stability Board (FSB) (2017), *Financial Stability Implications from Fintech: Supervisory and Regulatory Issues that merit Authorities' Attention*.

36. Tomić, V., Stojanovic, D. (2018), *Trends and innovations in mobile banking*, (Chapter book) In book: *Digital transformation: new challenges and business opportunities*, Publisher: London: Silver and Smith Publishers (290-310)
37. TWI2050 - The World in 2050 (2019). *The Digital Revolution and Sustainable Development: Opportunities and Challenges*. Report prepared by The World in 2050 initiative. International Institute for Applied Systems Analysis (IIASA), Laxenburg, Austria. [www.twi2050.org](http://www.twi2050.org)
38. Wieser C., Bruhn M., Kinzinger J., Ruckteschler C., Heitmann S. (2019), The Impact of Mobile Money on Poor Rural Households. Experimental Evidence from Uganda, Policy Research Working Paper 8913, World Bank Group and IFC-Mastercard Foundation Partnership for Financial Inclusion, June 2019.
39. UNCTAD. (2019). *Digital Economy Report 2019 – Value Creation and Capture: Implications for Developing Countries*.
40. United Nations Secretary-General's Task Force on Digital Financing of the Sustainable Development Goals. (2019). *Executive Summary: Harnessing Digitalization in Financing of the Sustainable Development Goals*.

## **DIFFERENCES AND PARTICULARITIES CONNECTED TO RETAIL MARKET CONCENTRATION: THE EVIDENCE FROM CROATIA**

**Ivan Kovac**

*University of Zagreb, Faculty of Economics and Business, Croatia  
ivan.kovac@efzg.hr*

### **ABSTRACT**

*The focus of this paper is to explore to what extent differences in the market share of the retailers in different statistical NUTS II regions (the Continental and the Adriatic) in Croatia, are related to the differences in their productivity, especially the differences related to their business result. The findings support the thesis that the differences in the retailers' market share in each statistical NUTS II region have statistically significant influence on the differences related to the very business result of these retailers. The results of the research in the Continental and the Adriatic statistical regions of Croatia prove that there are statistically significant differences relating to the gross profit per employee between the five strata of the retailers grouped according to the different market shares. Furthermore, the paper supports the assumption that there are specificities in the Continental and the Adriatic statistical regions of Croatia concerning these differences. The paper also presents the basic limitations of the research as well as recommendations for the future research.*

**Keywords:** *Croatia, market concentration, retail, statistical NUTS II regions*

### **1. INTRODUCTION**

Today, retail industry is a very important economic sector that is in many countries characterized by intensive dynamics of growth and so, it is becoming even greater and stronger generator of the GDP and added value. Most of all, it is becoming an economic branch that provides employment for more and more people (Bronnenberg and Ellickson, 2015). We are witnesses of an intensive and aggressive expansion of the leading global retail companies that spread to many countries worldwide by using different (multiple) store formats (Shi et al., 2018.). Many of these global players are successful in their campaigns to conquer foreign markets and are characterized by the general approach of globalization and internationalization. Due to the strong movement of retail companies on the international markets, some of them have become extremely big and powerful (Burt et al., 2003). But, under no means should we forget those that are for any reasons unsuccessful (Swoboda et al., 2018). Bearing in mind that modern retail is characterized by internationalization and concentration, along with the fast changes and great challenges they bring. Namely, today's global retailers are often facing slow economies in the countries they operate in and are dealing with demands that are becoming more and more specific regarding shopping options or social experience related to these options (Smith et al., 2018). On the wings of internationalization and globalization, whose development started to accelerate at the beginning of the 1980s, there begins a strong global expansion of the leading retail companies outside their home countries. It is the intense competition on the domestic market that is considered by many authors to be one of the main reasons for internationalization of their business i.e. exit of retailers onto new markets, outside their domestic boundaries (Papadopoulos and Martin Martin, 2011). The desire to grow, on one hand, and fierce competition on the domestic market on the other, in most cases represents the main motives of retail market players for entering the international market. For a long time, the literature has been gathering different researches highlighting internationalization and concentration as two key trends in retail industry (Tordjman, 1995). The process of retail market concentration has the phases of lower and higher intensity, but it has been taking place continuously for almost three decades. It is interesting to note that this process of concentration

on the specific market has been in progress according to an almost well-tried recipe. Namely, retail chains come to the specific market and achieve fast and above-average growth and therein market concentration in several ways. They achieve it through organic growth, acquisition or mergers, depending on the specificities of individual markets and the risks related to them. In that way, those retail companies become dominant in the channel of distribution in relation to other companies, and especially in relation to the manufacturers. Undoubtedly, internationalization and concentration have largely determined the structure and dynamics of today's global retail market (Dawson, 2006). The retail has become a highly globalized industry with strong and fast dynamics of changes and challenges. Namely, this industry is characterized by the emergence of new forms of retail on one hand, and the rising expectations and demands set by the consumers on the other. Naturally, in conditions of retail internationalization, global players in retail industry have to consider specificities of certain local markets and special habits and expectations of the consumers. Due to the fact that the retail market in the Republic of Croatia has been facing important changes in recent years, this paper analyzes the processes of retail market concentration and changes connected with them in each statistical region (NUTS II). Namely, the author deemed it important to establish and analyse the differences and particularities in productivity and business result connected to market concentration of the retail firms operating in the Continental and the Adriatic region of Croatia.

## 2. LITERATURE OVERVIEW

Internationalization and globalization on the global retail market, generally speaking, have the consequence of higher concentration on the market, with all their advantages and disadvantages for the economy in general, the retail companies and the consumers. Moreover, the studies have shown that retailer market concentration can have a significant influence on macro-economic movement in the entire economy of a country. Namely, the researches conducted in Japan suggest how retail market concentration, especially the discounts (rebates on the amount of goods procured from the supplier), connected with the volume of the purchased goods by the biggest retailers, has led to deflation of about 0.1% annually during „the lost decades“ (Ojima et al., 2018). Retail chains, due to their extremely strong business activities and big market shares, have created considerable market power. They have built an especially dominant position regarding food retail (Lloyd et al., 2015). Over the years, the literature has been offering many papers that investigate the connection between the level of internationalization of certain companies and their business success. Assuredly, the authors offer many different opinions, be it from the theoretical point of view, or from the practical aspects of this important phenomenon in retail (Hitt et al., 2006.). It is understandable that high level of business internationalization leads to the increased costs of processing the information. Namely, in order for such a company to be successful, it should focus on the specificities of each market regarding, for example, the logistics, local consumers, trade regulations etc. (Sundaram and Black, 1992). It is understandable that internationalization and globalization of the retail market has the consequence of the arising concentration of this market globally, and locally. Namely, the leading retail chains, in the conditions of expanding onto international market, have achieved fast growth. It has especially been evident in the EU, where the leading (foreign) retailers have had a far bigger growth rate than it has been the average growth on the level of retail as industry (Dawson, 2006). If we want to simplify the defining of the concentration as a market phenomenon, then we could say that the retail market is characterized by a high concentration if there are few retail companies with high market shares. Opposite to that, the market is less concentrated if there are many business subjects operating there with each having only a small share. On the global scale, in 2017, the first ten retail companies generated 31.6% of the revenue of the top 250 biggest retailers in the world, while their concentration in 2016 was 30.7% (Deloitte, 2019).



In other words, the concentration grew in 2017 in relation to 2016. In the strong process of internationalization of retail i.e. business exit of the leading retail companies outside their primary market, we can encounter a really small number of exceptions that are not following this modern trend of expanding onto international markets (Treadgold, 1991). One of them is The Kroger Co., (USA), the third largest retail company in the world and the only one in the first ten companies in the world that does not operate outside its home country. This company proves that it is possible to be successful in retail without internationalizing your business. However, the size and the purchasing power of a country like the USA where this successful retail giant operates have to be taken into consideration. The success of the leading retail companies on a new market depends on many different factors. More recent studies suggest that, besides to other factors, the attention should be given to the speed of the very market internationalization, format diversification etc. (Hoppner and Griffith, 2015). The strong negotiating position of the leading retail companies in relation to their suppliers enables them to obtain lower purchase prices and costs rationalization in general, which creates preconditions for a more rational and successful business. Pursuant to that, due to their privileged position, their business is characterized by a higher productivity in relation to their rivals on the market. Generally, they grow faster and have a strong accumulation that enables them to invest in new technologies and to implement innovations into their business. It has been long known that new technologies and above all, innovations are among the most important factors of development of the economy and the companies individually (Kosala, 2015). Many studies confirm the importance, but also the necessity of innovations in retail, particularly those related to the continual introduction of new formats in retail (Reinartz et al., 2011). Namely, many researches show that understanding the current phases of the life cycle of certain formats in retail is of great significance (Klein and Schmitz, 2016; Maruyama et al., 2016). Quite a while ago some authors explored retail internationalization focusing on its scope, scale and its directions (Doherty, 2000). In general, the literature offers perspectives from different authors that clearly suggest how internationalization in business brings the benefits and costs to the business subject. Those authors who highlight the benefits mostly point to economies of scale and scope (Caves, 1971). Some other authors, in the context of the advantages of internationalization, list other benefits as well, like, for example, operative flexibility, knowledge development and the advantages of organizational learning (Chang, 1995). On the other hand, some other scientists have pointed out how internationalization brings costs. This is mainly related to the difficulties in managing and coordinating different activities connected with doing business in more than one country (Gomes and Ramaswamy, 1999). The literature, as previously mentioned, offers quite a number of papers, mostly from the area of international business and strategic management, and focusing on the research of the relationship between the level of internationalization of the individual business subjects and their business performance. Opposite to that, there are much fewer theoretical and empirical papers that scientifically analyse internationalization–performance (I–P) and the relationship between business success and internationalization of business subjects. However, it is important to point out that the findings of those scientific researches do not show the consensus regarding a clear contribution of business internationalization of retail companies to their business success. Moreover, such and similar results related to this important topic we can also find in the researches dealing with the international business and strategic management. Some papers show the results that support positive connection between internationalization and business performance of retail companies (Etgar and Rachman-Moore, 2008). On the contrary, there are papers that suggest internationalization have negative influence on the business success of retailers (Mohr and Batsakis, 2014). But, above all, it is interesting to note more recent results of the studies dealing with this topic. In this context, the paper presenting the ideas of the undulating relationship between internationalization and business success of retail companies based on theoretical and

empirical analyses, should be mentioned (Dimitrova et al. 2019). Namely, the authors come to the conclusion that internationalization first has a negative impact, then a positive one, then again assumes negative influence on business performance of the retailers over a longer period of time. Moreover, the same authors suggest that the two variables, the expansion of the foreign market and format diversification in retail, moderate the relationship between internationalization and business success of retail companies. The growth of foreign market builds up the S-curve relationship between internationalization and business performance, while the format diversification in retail does exactly the opposite. In general, modern retail market is characterized by internationalization and concentration, the fast changes and the challenges related to them. Today, we are witnessing the situation in which leading companies in retail strive to continuously develop retail formats in order to remain successful on this extremely demanding and competitive market (Hino, 2014). Introduction and development of new retail formats is becoming one of the key determinants of modern retail that especially concerns food retail. This process did not start yesterday, it has been running for years, and lately, it has intensified. In line with that, it is clear that with products and retail formats, there are different phases through which a retail format goes through during its life cycle.

### **3. RESEARCH AND METHODOLOGY**

The primary goal of this research was to investigate to what extent the differences in the level of retail market concentration in the Republic of Croatia are related to the differences in the productivity and business result of the retail firms that operate on the Croatian market. Supporting this, the literature presents papers pointing to the direct correlation between market concentration and business success i.e. profitability of the retail firms (Rickert et al., 2018). Since the trend of concentration growth is present on the Croatian retail market as well, it was important to explore what influence market concentration growth has on the business activities of the leading market players in each statistical region (NUTS II) in the Republic of Croatia. Thirty-six Croatian leading retail firms dealing with fast-moving consumer goods, mostly food, beverage and household hygiene products, were selected for the research. The main criterion was their market share. The data were collected from the analysis of the financial reports of these retail firms that were available on the websites of the Croatian Financial Agency (FINA) and the Croatian Agency for Market Regulation (AZTN). SPSS 20 software was used for statistical analysis of the data for the period from 2014 to 2018. The research was conducted in late 2019. The main assumption of this research paper is based on the differences in the market share of the retail firms that have statistically significant influence on the differences related to the productivity and business success of the retail firms in Croatia. Furthermore, the paper supports the assumption that there are specificities in the Continental and the Adriatic statistical regions of Croatia concerning these differences (NUTS II statistical regions). The sample that consisted of the leading retailers was divided into five strata in each NUTS II statistical region i.e. in Continental Croatia and in Adriatic Croatia (Table 1 and Table 2). The total revenue and the number of employees, connected with the realization of this total revenue of each single retail firm (operating on the entire area of Croatia), were distributed in NUTS II statistical regions based on the number and the structure (retail formats) of the retailers. The available indicators from the Croatian Agency for Market Regulation were used for certain data correction, the data related to the structure of the total revenue of all the retailers per each county and Zagreb City (AZTN 2018). The criterion for calculating the market share was the total revenue of the retailers. In line with that, the retailers were divided into five strata, those with the share up to 1%, those with the share from 1 to 5%, then those with 5 to 10%, those with 10 to 20% and finally, those with the market share of over 20%. The retailers were divided into the strata based on the average market share, analysed for the period from 2014 to 2018. In this way, the consistency of the market share throughout the period of the five years has been

secured, aiming at achieving the clearest possible analysis of the movement of the fast-moving consumer market (mostly food, beverage and household hygiene products) in the Republic of Croatia.

<b>Concentration of retailers</b>	<b>Number of retailers</b>	<b>Structure of the sample (%)</b>	<b>Total share in retail (%)</b>
> 20%	1	3,85%	31,93%
10% - 20%	1	3,85%	11,62%
5% - 10%	4	15,38%	31,45%
1% - 5%	9	34,62%	19,02%
< 1%	11	42,30%	5,98%
<b>Total</b>	<b>26</b>	<b>100%</b>	<b>100%</b>

*Table 1: Research sample of Continental Croatia  
(Source: Author's calculation)*

The first strata in the analysed sample are those retailers that occupy more than 20% of the food, beverage and household hygiene products market in Croatia. There is only one retailer in this stratum operating in Continental and in Adriatic Croatia. It is Konzum, the biggest retail chain in Croatia. The average market share of Konzum in the period from 2014 to 2018 was 30% in the whole area of Croatia. It is necessary to explain in more detail the trends connected not only to Konzum, but also to the concern it belongs to. Konzum is a part of “Fortenova” concern (the former “Agrokor” concern) that has been going through a dramatic phase over the last couple of years, concerning the restructuring and the very ownership. After a really long period of an intense over-borrowing and inefficient business, the creditors and the investors (with the help from the government and a special act that was passed) take over the concern, which further reflected badly on the business activities of Konzum, being one of the biggest constituents of the concern. Under these circumstances, there was a strong revenue decrease for Konzum in 2016 and 2017. In the five-year period (2014-2018), the market share of Konzum on the Croatian market dropped by 27.5% i.e. 8.89 percentage points. Namely, the market share of Konzum in 2014 was 32.27%, while in 2018, its share dropped to 23.38%. Along with the above-mentioned reasons, Konzum loses a market share due to the growth of its main competitors (Lidl, Plodine, Kaufland, Spar, Tommy). By analysing the sample in the Continental region of 26 retail firms, we can see that the second stratum, with the share from 10 to 20%, is also occupied by only one retailer, holding 11.62% of the market share. The other 24 retailers have been distributed into other three strata, as evident in Table 1.

*Table following on the next page*

<b>Concentration of retailers</b>	<b>Number of retailers</b>	<b>Structure of the sample (%)</b>	<b>Total share in retail (%)</b>
> 20%	1	6,25%	27,75%
10% - 20%	3	18,75%	37,45%
5% - 10%	3	18,75%	24,72%
1% - 5%	5	31,25%	8,28%
< 1%	4	25,00%	1,80%
<b>Total</b>	<b>16</b>	<b>100%</b>	<b>100%</b>

*Table 2: Research sample of Adriatic Croatia  
(Source: Author's calculation)*

The research sample in Adriatic Croatia (Table 2) consists of 16 retail firms that are structured as in the previous statistical NUTS II region (Continental Croatia, Table 1). By comparing the market concentration of the Continental region to the Adriatic region of Croatia, we can see that the top six retailers hold 75% of the market. On the other hand, in Adriatic Croatia, the top seven retailers control 89.92% of the market.

#### **4. RESULTS AND DISCUSSION**

Since the revenue per employee is a rational analytical means, Tables 3 and 4 show average revenue per employee for each of the five strata, for each of the year in the observed period, for the Continental and the Adriatic region.

<b>Variables</b>	<b>Market share</b>	<b>2014</b>	<b>2015</b>	<b>2016</b>	<b>2017</b>	<b>2018</b>	<b>Mean</b>
<b>Revenue per employee (000 HRK)</b>	> 20% individual share (top1)	1508,98	1580,95	1224,35	1188,81	1349,22	<b>1370,46</b>
	10-20% individual share (1 firm)	2217,54	2317,62	2207,01	2296,84	25,9,71	<b>2309,74</b>
	5-10% individual share (4firms)	1285,07	1201,65	1201,9	1334,29	1306,85	<b>1265,95</b>
	1-5% individual share (9 firms)	671,74	690,18	668,38	707,64	696,97	<b>686,98</b>
	< 1% individual share (11firms)	876,87	845,23	830,44	895,16	869,83	<b>863,51</b>
	Total (top 26)	<b>1312,04</b>	<b>1327,13</b>	<b>1226,42</b>	<b>1284,55</b>	<b>1346,52</b>	<b>1299,33</b>

*Table 3: Revenue per employee of Continental Croatia in the period 2014-2018  
(Source: Author's calculation)*

Due to the fact that revenue per employee points to the efficiency (productivity) of the employees in the specific retail firm, every retailer strives at achieving as larger ratio of revenue per employee. It is important to note that often, those retailers that have a large share of revenue per employee i.e. high productivity, are often also those that are profitable. This also highlights

the importance of the investment in the human capital and the creation of employees that are highly productive. Naturally, highly productive employees create preconditions for the retailers to be profitable. The analysis of the productivity has shown that the retail firms in both statistical regions of Croatia with the share between 10 and 20% are those with the highest productivity. In Continental Croatia, this productivity is higher (2,309.740 HRK revenue per employee), while the productivity in the Adriatic part is lower (1,491.720 HRK). Lower productivity in the Adriatic region is understandable, bearing in mind the geographical characteristics of the area (islands) and the structure of the retail formats (more smaller stores and self-service stores). The second highest productivity in Continental Croatia has the retailer with the market share of over 20% (1,370.460 HRK). It is Konzum, whose business situation we have already explained. Concerning Adriatic Croatia, the second highest productivity is achieved by three retailers with the share between 5 and 10% (1,072.050 HRK). In this market, the retailer with the highest market share (Konzum) is only in the third place (747.500 HRK), which is way below the average productivity of all 36 retailers on the Croatian market (1,086.320 HRK). Understandably, this low productivity of Konzum can be mostly related to the share of small stores and self-service stores in their retail network in Adriatic Croatia. Namely, it is clear that productivity, to a larger extent, also depends on the level of efficiency the business processes achieve, connected to the retail format that largely dominates the specific market. Research shows that in Croatia, in 2017, 70% of the revenue from the sales of the listed products, the retailers realized in the big format stores. More accurately, 47% of the sales were realized in the supermarkets, 23% in the hypermarkets, 21% in the self-service stores and only 9% in the small stores (AZTN, 2018).

Variables	Market share	2014	2015	2016	2017	2018	Mean
<b>Revenue per employee (000 HRK)</b>	> 20% individual share (top1)	823,01	862,21	667,83	648,52	735,91	<b>747,5</b>
	10-20% individual share (3 firms)	1428,14	1491,52	1429,42	1519,67	1589,86	<b>1491,72</b>
	5-10% individual share (3 firms)	1097,4	986,01	1001,34	1152,55	1122,95	<b>1072,05</b>
	1-5% individual share (5 firms)	680,74	724,65	701,74	749,14	740,07	<b>719,27</b>
	< 1% individual share (4 firms)	692,93	693,6	625,61	662,71	701,16	<b>675,21</b>
	Total (top 16)	<b>944,44</b>	<b>951,61</b>	<b>885,19</b>	<b>946,52</b>	<b>978</b>	<b>941,15</b>

*Table 4: Revenue per employee of Adriatic Croatia in the period 2014-2018 (Source: Author's calculation)*

Therefore, Konzum has closed more than a hundred unprofitable retail stores in the last couple of years. Generally, the acquired results are in line with previous research and they point to the fact that market concentration of the retail subjects, as well as the increase of the size of the retail store are directly linked with their productivity (Goodman et al., 2009; Usova, 2017). As previously pointed out, this research supports the assumption that the level of market share of the retail firms in two different statistical NUTS II regions (the Continental and the Adriatic region) in the Republic of Croatia have a statistically significant influence on their business

result (gross/net result per employee). Taking into consideration all of the above-mentioned, we assume that the differences connected with the market shares of the retailers have a statistically significant influence on the differences relating to the business success (gross/net result per employee) of these business subjects in two different statistical NUTS II regions in the Republic of Croatia. The research is conceptualized in such a way that the dependant variable is presented by the average value of the realized gross profit per employee for the analysed retailers in the Republic of Croatia for the period from 2014 to 2018 for each statistical region, Continental and Adriatic Croatia.

Gross profit is the difference between the business income and the costs of goods sold. The independent variable is the market share of the analysed retailers as the crucial measure of the market concentration. In line with that, Tables 5 and 6 offer a detailed representation of the movements of the gross profit per employee through the analysed period considering their market shares for each statistical NUTS II region in Croatia.

Variables	Market share	2014	2015	2016	2017	2018	Mean
<b>Gross profit per employee (000 HRK)</b>	> 20% individual share (top1)	19,07	31,75	-214,5	-502,23	-39,64	<b>-141,11</b>
	10-20% individual share (1 firm)	65,11	124,39	155,47	156,84	16,92	<b>103,75</b>
	5-10% individual share (4firms)	53	-6,63	-0,1	6,26	14,56	<b>13,42</b>
	1-5% individual share (9 firms)	18,15	23,63	24,9	32,26	32,33	<b>26,25</b>
	< 1% individual share (11firms)	12,45	17,66	19,34	26,38	27,11	<b>20,59</b>
	Total (top 26)	<b>33,56</b>	<b>38,16</b>	<b>-2,98</b>	<b>-56,1</b>	<b>10,26</b>	<b>4,58</b>

*Table 5: Gross profit per employee of Continental Croatia in the period 2014-2018  
(Source: Author's calculation)*

Tables 5 and 6 show that that the highest gross profit per employee in both Croatian NUTS II regions (the Continental and the Adriatic region) is realized by the retailers with the market share between 10 and 20%. These are the same retailers that have been proven to have the highest revenue per employee.

It is important to note that gross profit per employee for the analysed period is almost double in the Continental NUTS II region than in the Adriatic NUTS II region. This can be the result of the geographical characteristics of the Adriatic NUTS II region, and consequently of the structure of the retail formats (the number of small stores and self-service stores). Konzum, being the largest retailer, realizes loss (negative gross profit per employee) in both NUTS II regions because of the reasons that have been mentioned earlier.

Variables	Market share	2014	2015	2016	2017	2018	Mean
<b>Gross profit per employee (000 HRK)</b>	> 20% individual share (top1)	10,41	17,31	-117	-273,97	-21,62	<b>-76,98</b>
	10-20% individual share (3 firms)	36,41	60,24	76,11	88,22	38,23	<b>59,84</b>
	5-10% individual share (3 firms)	-6,71	-13,59	-7,97	-3,87	6,51	<b>-5,05</b>
	1-5% individual share (5 firms)	24,46	35,64	33,12	39,18	36,62	<b>33,8</b>
	< 1% individual share (4 firms)	6,64	20,59	14,03	3,54	22,84	<b>13,53</b>
	Total (top 16)	<b>14,24</b>	<b>24,03</b>	<b>-0,33</b>	<b>-29,32</b>	<b>16,52</b>	<b>2,03</b>

Table 6: Gross profit per employee of Adriatic Croatia in the period 2014-2018  
(Source: Author's calculation)

Negative business result (gross profit per employee) is also recorded at the retailers with the market share from 5 to 10% operating in the Adriatic NUTS II region. In this stratum, two foreign retailer chains are dominant (Kaufland and Spar) that, since their arrival on the Croatian market (about ten years ago), have been recording losses.

Variables	Descriptive Statistics					
	Valid N	Mean	Minimum	Maximum	Std.Dev.	Standard Error
>20%K	1	-141,11	-141,11	-141,11		
10-20%K	1	103,75	103,75	103,75		
5-10%K	4	2,93	-34,99	35,21	33,64	16,82
1-5%K	9	26,86	4,66	48,93	15,72	5,24
<1%K	11	20,59	-11,17	131,14	38,81	11,70
TOTAL K	26	17,02	-141,11	131,14	46,81	9,18

Table 7: Descriptive indicators for gross profit per employee of Continental Croatia (000 HRK),  
(Source: Author's calculation)

Since the main aim of this paper was to investigate the influence of the market concentration on the market players i.e. their business result for each statistical NUTS II region in the Republic of Croatia, the one-way analysis of variance ANOVA was used. The aim was to establish whether the differences in the market share have statistically relevant influence on the differences related to the gross profit per employee in each statistical NUTS II region, and in order to define the specificities in each statistical NUTS II region in Croatia, related to this very important issue. On the other hand, we have used descriptive indicators for displaying the variables of measurement. Table 7 clearly shows that the highest gross profit per employee in the Continental NUTS II region in Croatia is held by the retailers with the markets share between 10 and 20% (M= 103.750 HRK). Compared to that, the retailers with the share of over 20% (M= -141.110 HRK) have the highest negative gross profit per employee. We have already explained on several occasion the reasons why this is so. The results acquired with the one-way analysis of variance ANOVA (Table 8) confirm that the differences in the market share have

statistically significant influence on the differences connected with the business results (gross profit per employee) of the retailers in the Continental Croatia. Namely, the research findings suggest that, among the five strata of the retailers grouped according to different market shares, there is statistically significant difference in the gross profit per employee ( $F = 11,20992$ ;  $p < 0,01$ ).

Effect	Univariate Tests of Significance for TOTAL Sigma-restricted parameterization Effective hypothesis decomposition				
	SS	Degr. of Freedom	MS	F	p
CATEGORIES	41795,70	4	10448,92	11,20992	0,000041
Error	20506,51	22	932,11		

Table 8: Values of F-statistics of Continental Croatia  
(Source: Author's calculation)

To confirm the acquired results, we used the Post hoc test (Scheffe). Based on the test results, we can conclude that there is the biggest statistically significant difference in the Continental Croatia between the retailers that have over 20% market share and all those in other strata.

Variable	Descriptive Statistics					
	Valid N	Mean	Minimum	Maximum	Std.Dev.	Standard Error
>20%	1	-76,98	-76,98	-76,98		
10-20%	3	59,84	26,94	103,79	39,60	22,86
5-10%	3	-5,06	-35,00	35,29	36,28	20,95
1-5%	5	33,93	7,83	77,70	27,31	12,21
<1%	4	13,53	-9,01	39,22	19,81	9,91
TOTAL	16	19,45	-76,98	103,79	42,52	10,63

Table 9: Descriptive indicators for gross profit per employee of Adriatic Croatia (000 HRK),  
(Source: Author's calculation)

Table 9 shows how the highest gross profit per employee in the Adriatic NUTS II region in Croatia is realized by the retailers with the market share between 10 and 20% ( $M=59.840$  HRK). It is important to note that gross profit per employee in the analysed period was half the profit realised in the Continental region. The retailers with the share of over 20% ( $M= -76.980$  HRK) have the highest negative gross profit per employee. The reasons for that have already been explained above.

Effect	Univariate Tests of Significance for TOTAL Sigma-restricted parameterization Effective hypothesis decomposition				
	SS	Degr. of Freedom	MS	F	p
CATEGORIES	22932,74	4	5733,186	6,724413	0,004439
Error	10231,11	12	852,593		

Table 10: Values of F-statistics of Adriatic Croatia  
(Source: Author's calculation)



The results acquired with the one-way analysis of variance ANOVA (Table 10) confirm that the differences in market share of have a statistically significant influence on the differences connected with the business results (gross profit per employee) of the retailers of Adriatic Croatia. The research findings suggest that, among the five strata of the retailers grouped according to different market shares, there is statistically significant difference in the gross profit per employee ( $F = 6,724413$  ;  $p < 0,01$ ). To confirm the acquired results we used the Post hoc test (Scheffe). Based on the test results, we can conclude that there is the biggest statistically significant difference in the Mediterian Croatia between the retailers that have over 20% market share and those that have 10 – 20% market share. The results of the research are in line with the results found in the literature which also support the direct correlation between the market concentration and business success of the retailers (Hovhannisyan and Bozic 2016; Rickert et al., 2018).

## 5. CONCLUSION

Today, we are witnessing how retail has become a highly globalized industry, with strong and fast changes and dynamic challenges. It has become a significant economic sector, in many countries characterized with intense growth, becoming a growing and more powerful generator that creates gross domestic product and added value. The processes of globalization, internationalization and concentration of global economy are clearly outlined in the trends in retail, globally and in Croatia. The Croatian retail market has become internationalized and concentrated, defined by strong and fast changes and pretty big challenges. The focus of the author in this paper was, first and foremost, to explore to what extent differences in the market share of the retailers in different statistical NUTS II regions (the Continental and the Adriatic) in Croatia, are related to the differences in their productivity, especially the differences related to their business result. Bearing in mind what has previously been mentioned, the basic research interest of the author was to investigate the influence of the Croatian retail market concentration on specific market players i.e. their productivity and business result. For the purpose of this paper, 36 leading retailers dealing with fast-moving consumer goods (mostly food, beverage and household hygiene products) in the Republic of Croatia for the period from 2014 - 2018 have been chosen. The paper starts out from the assumption that the differences in the retailers' market share have statistically significant influence on the differences related to the business result of the retailers in each statistical NUTS II regions in Croatia (gross result per employee). The findings support the thesis that the differences in the retailers' market share in each statistical NUTS II region have statistically significant influence on the differences related to the very business result of these retailers. In line with the previously mentioned facts, the results of the research in each statistical NUTS II region in Croatia prove that there are statistically significant differences relating to the gross profit per employee between the five strata of the retailers grouped according to the different market shares. The findings suggest that there is the biggest statistically significant difference in the Continental Croatia between the retailers that have over 20% market share and all those in other strata. Based on the conducted research in the Adriatic Croatia the biggest statistically significant difference is between the retailers that have over 20% market share and those that have 10 – 20% market share. The main limitations of this research relate to the unavailability of concrete data on the retailers in the Republic of Croatia. The research was based on insufficient number of the indicators of the business success (gross profit per employee), which can lead to a simplified conclusion. Future research efforts should aim at the broader panel of indicators. These indicators should include the net result per employee, ROA (return on total assets), ROE (return on equity), inventory turnover coefficient, etc.

**LITERATURE:**

1. AZTN, Croatian Agency for Market Regulation (Agencija za zaštitu tržišnog natjecanja), (2018). *"Prikaz tržišta trgovine na malo mješovitom robom, pretežno hranom, pićima i higijenskim proizvodima za domaćinstvo u Republici Hrvatskoj u 2018."*
2. Bronnenberg, B.J., & Ellickson, P.B. (2015). *Adolescence and the Path to Maturity in Global Retail*. Journal of Economics Perspectives, 29(4), 113-134.
3. Burt, S., J. Dawson, and L. Sparks. 2003. *"Failure in International Retailing: Research Propositions"*. International Review of Retail, Distribution and Consumer Research 13 (4): 355–373.
4. Caves, R. E. (1971). *International corporations: The industrial economics of foreign investment*. Economica, 38(149), 1.
5. Chang, S. J. (1995). *International expansion strategy of Japanese firms: capability building through sequential entry*. Academy of Management Journal, 38(2), 383–407.
6. Dawson, J. (2006). *Retail Trends in Europe*. In M. Kraft & M.K. Mantrala (Eds.), *Retailing in the 21st Century* (pp. 41-58). Berlin: Springer.
7. Deloitte, *Global Powers of Retailing 2019*, <https://www2.deloitte.com/content/dam/Deloitte/global/Documents/Consumer-Business/cons-global-powers-retailing-2019>.
8. Dimitrova, B., Kim, S., & Smith, B. (2019): *Performance of International Retailers: Empirical Evidence of an S-Curve Relationship*, Journal of Global Marketing, 32:3, 154- 176.
9. Doherty, A.M. (2000), *"Factors influencing international retailers market entry mode"*, Journal of Marketing Management, Vol. 16, pp. 223-45.
10. Etgar, M., & Rachman-Moore, D. (2008). *International expansion and retail sales: an empirical study*. International Journal of Retail & Distribution Management, 36(4), 241–259.
11. Gomes, L., & Ramaswamy, K. (1999). *An empirical examination of the form of the relationship between multinationality and performance*. Journal of International Business Studies, 30(1), 173–187.
12. Goodman, C., Kachur, S.P., Abdulla, S., Bloland, P., & Mills, A. (2009). *Concentration and drug prices in the retail market for malaria treatment in rural Tanzania*. Health Economics, 18(6), 727-742.
13. Hino, H. (2014). *Shopping at different food retail formats*. European Journal of Marketing, 48(3/4), 674 -698.
14. Hitt, M. A., Tihanyi, L., Miller, T., & Connelly, B. (2006). *International Diversification: Antecedents, Outcomes, and Moderators*. Journal of management, 32(6), 831–867.
15. Hoppner, J. J., & Griffith, D. A. (2015). *Looking back to move forward: A review of the evolution of research in international marketing channels*. Journal of Retailing, 91 (4), 610–626.
16. Hovhannisyan, V., & Bozic, M. (2016). *The effects of retail concentration on retail dairy product prices in the United States*. Journal of Dairy Science, 99(6), 4928-4938.
17. Klein, A., Schmitz, G. (2016). *Main-format dominance in consumers' FMCG cross-format shopping patterns*. Journal of Retailing and Consumer Services, 30, 105-115.
18. Kosala, M. (2015). *Innovation Processes as a Stimulant of Internationalisation Process of Firms*. Entrepreneurial Business and Economics Review, 3(2), 65-84.
19. Lloyd, T. A., McCorriston, S. and Morgan, C. W. (2015) *"Experience of food inflation across the EU"*, In McCorriston, S. (ed.), *Food Price Dynamics and Price Adjustment in the EU*. Oxford: Oxford University Press, p. 208. ISBN 9780198732396.
20. Maruyama, M., Wu, L., Huang, L. (2016). *The modernization of fresh food retailing in China: The role of consumers*. Journal of Retailing and Consumer Services, 30, 33-39.

21. Mohr, A., & Batsakis, G. (2014). *Intangible assets, international experience and the internationalisation speed of retailers*. *International Marketing Review*, 31(6), 601–620.
22. Ojima, M., Shino, J., Ueda, K. (2018). *Retailer Market Concentration, Buyer-Sizediscounts and Inflation Dynamics*, *The Japanese Economic Review*, Vol. 69, No. 1,
23. Papadopoulos, N., and O. Martin Martin. 2011. *International market selection and segmentation: Perspectives and challenges*, *International Marketing Review* 28, no. 2: 183–200.
24. Reinartz, W., Dellaert, B., Krafft, M., Kumard, V., & Varadarajan, R. (2011). *Retailing Innovations in a Globalizing Retail Market Environment*. *Journal of Retailing*, 87(1), 53-66.
25. Rickert, D., Schain, J.P., & Stiebale, J. (2018). *Local market structure and consumer prices: Evidence from a retail merger*. DICE Discussion Paper, 1-47; 280; <http://hdl.handle.net/10419/173247>.
26. Shi, Y., Lim, J. M., Weitz, B. A., & France, S. L. (2018). *The impact of retail format diversification on retailers' financial performance*. *Journal of the Academy of Marketing Science*, 46(1), 147–167.
27. Smith, B., Rippe, C. B., & Dubinsky, A. J. (2018). *India's lonely and isolated consumers shopping for an in-store social experience*. *Marketing Intelligence & Planning*, 36(7), 722–736.
28. Sundaram, A. K., & Black, J. S. (1992). *The environment and internal organization of multinational enterprises*. *Academy of Management Review*, 17(4), 729–757.
29. Swoboda, B., Morbe, L., & Hirschmann, J. (2018). *International strategy's effects on retailers' local implementation and performance*. *International Business Review*, 27(3), 642–653.
30. Tordjman, A. (1995). *European Retailing: convergences, differences and perspectives*. P.J. McGoldrick & G. Davies (Eds.), *International Retailing* (pp. 17-42). London: Pitman Publishing.
31. Treadgold, A.D. (1991), “*The emerging internationalization of retailing: Present status and future challenges*”, *Irish Marketing Review*, Vol. 5, No. 2, pp. 1-27.
32. Usova, N.V. (2017). *Identification of consumer development trends in a major city: a market-based approach*. *R-economy*, 3(1), 50-58.

# NEGATIVE CONSEQUENCES OF CREATIVE ACCOUNTING UNDER THE CONDITIONS OF SELECTED EASTERN EUROPEAN ECONOMIES

**Monika Poradova**

*University of Zilina, Faculty of Operation and Economics of Transport and Communications,  
department of economics, Univerzitna 1,010 26 Zilina, Slovakia  
monika.poradova@fpedas.uniza.sk*

## ABSTRACT

*Concepts associated with Creative Accounting became popular only two decades ago, but there has always been a desire to manipulate the financial statements of companies. The aim of the presented paper is to clarify the negative consequences of creative accounting under the conditions of selected eastern European economies. The paper presented consists of 4 parts. In the first part, the paper deals with the concept of creative accounting, were introduced definitions that indicate how it is perceived by different occupational groups and how it is assessed as a phenomenon regularly occurring in the normal economic cycle, which of course affects. The following are the causes of its increasing usability, which features of accounting help bias in accounting information and in which spheres of the economic environment we can find it. The following chapter covers the individual practices of creative accounting where it tried to name at least the most important of them. Their knowledge should be user to help identify them because, based on the information provided by the company, it does their economic decisions. However, the content of this section also suggests that a number of techniques that can be used to misrepresent financial statements is really many, and their creators gives really a lot of space to adapt the presented data to your image. Comparison of creative accounting in the Slovak Republic and the Czech Republic was carried out based on data set from ministries of internal affairs in the third chapter of this paper. The fourth part is devoted to the conclusions of the paper presented. A descriptive method, analysis, mathematical-statistical methods, graphic methods, comparison and synthesis was used in the processing of the paper submitted. The result of this paper is a comprehensive overview of the negative consequences of creative accounting.*

**Keywords:** *Creative accounting, Economic impact, Prevention, Economic crime, Earnings management*

## 1. INTRODUCTION

The concept of creative accounting has recently been declining in the context of almost everyone accounting fraud. (Sadaf, Oláh, Popp, Mate 2018) The practices used by American companies have emerged Enron or WorldCom, which resulted in the collapse of both companies and the subsequent collapse stock market. There are societies mentioned in Europe in connection with this issue Ahold and Parmalat. The concept of creative accounting is also used today at the level of the state sphere. To newspaper pages Greece has recently been accused of having violated the rules of the Stability Pact and Growth when trying to hide the deficit with the help of various tricks to achieve the desired 3% threshold. In September 2004, it was found that Greece had submitted incorrect data since Greek deficit had to be corrected from the presented 1.7% to a real 4.6%. "These are legal operations, but they cannot be considered a deficit reduction," said Commissioner Pro monetary affairs Joaquín Almunia of the Financial Times.

## **2. METHODOLOGY**

The definition of this concept differs in many sources. There are several ways creative accounting define. Probably the most complicated problem of precise delimitation is a comparison of the terms ethics and legality. Within this issue, questions arise as to what is ethical and what not, and when unethical becomes illegal.

### **2.1. Empirical definitions of creative accounting**

All companies distort their profits. Each set of published financial statements is based on books that are either gently "cooked" or completely "baked" .Numbers presented twice a year they are altered to protect the culprits. It's the biggest scam ever Trojan horse. However, in truth, this deception is excellently accomplished. It is absolutely legitimate. It's creative accounting. (Healy, Cleary, Walsh 2018). (Crawely, Wahlen 2014), reporting on her experience as an investment analyst – We have already felt that the apparent increase in profits that occurred in the 1980s was rather the result of accountants tricks than real economic growth, so we decided to show the main intricacies techniques and show them on examples of companies using these techniques.

### **2.2. Academic definition of creative accounting**

Here I would like to mention the opinion of Kamal (Kamal Naser, H. M. (1993) who states that creative accounting can be defined as the process of manipulating accounting data, using loopholes in accounting policies and the choice of scales and reporting method used to transform financial statements into what their contractors prefer, they should have. (Marilena, Corina 2012) The process by which transactions are structured to create the required accountants results rather than being presented in a neutral, constant way. It can be seen that both empirical and academic concepts have something in common. Both perceive creative accounting as a common phenomenon. Both agree that these practices are dishonest and undesirable. Under current accounting conventions associated with legal requirements, it exists still great flexibility and volatility. This, together with them, allows the various functions to work alternative practices. The result is tailor-made accounting, which fully reflects needs of the company, so that its financial statements give a misleading or unimaginative picture of hers financial position.

### **2.3. Tactics of creative accounting**

After several accounting scandals floated to the surface, it is possible to find inexhaustible a number of resources that attempt to analyze tactics and forms of creative accounting. There are many concepts that are related to the bias of the financial statements of the firms he has result in inaccurate information to users of accounting information, they are intended for naming certain areas of this issue. These tactics may be divided in the following way. (Vochozka, Rowland, Vrbka 2016)

Aggressive accounting is impressive and deliberate selection and use of accounting principles that are implemented in the efforts to achieve desirable results, so that subsequent practices are in line with GAAP or not. Earnings Management is continuous manipulation of profits to aim for a predetermined goal. This goal can be set by management or it can try to fulfill it analysts' predictions, or it may be the amount to match a certain one a smooth, more sustainable flow of profits (Kovacova, Kliestik 2017). Income smoothing is a form of earnings management where the main effort is to minimize differences between peaks and sinks in the normal time series of gains. Of course, these efforts includes attempts to reduce and withhold profits over good years and use them in weaker years.

Fraudulent financial reporting are the cases where intentional misstatements or intentional omissions are made or data in financial statements with the intention of deceiving users of accountants information. This behavior is defined as either fraudulent in administrative, civil or criminal proceedings. Practices of creative accounting are some or all of the steps used in the handling of numbers, including aggressive selection and application of accounting principles, fraudulent financial reporting; and any steps towards earnings management and income smoothing.

#### **2.4. Major techniques of creative accounting**

Commonly known techniques that are used for creative accounting purposes themselves somewhat reflect its basic classification given above. These are the techniques included under The term window dressing, which is represented by data manipulations and is more or less and then those that are labeled as sophisticated, which are very difficult to detect even highly qualified auditors. They fall under the term off-balance sheet financing (OBSF) - off-balance sheet financing. The Institute of Certified Accountants in England and Wales (ICAEW) defined in 1986 window dressing as such, conducting transactions in which financial statements are misleading or an unrepresentative picture of the company's financial situation. The same institute further defined the term off-balance-sheet financing as such financing or refinancing of business activities, which are in compliance with legal requirements and existing accounting policies may not appear in the balance sheet. The main techniques of window dressing include:

- Sale and repurchase of assets.
- Certain property revaluation practices.
- Changes in adopted accounting policies and intentional errors.
- Intentional reporting of short-term assets and debt between long-term and vice versa.
- Distorted revenue recognition.
- Failure to observe the precautionary principle in accounting.
- Distorted valuation of assets in the balance sheet at the time of acquisition.
- Estimated useful life of an asset that is intentionally made erroneously.
- Replacing asset upgrades with repairs or vice versa.
- Reporting assets that do not bring economic benefits to the enterprise.
- Loans over the reporting period.

The main off-balance-sheet financing techniques include:

- Replacing the so-called capital (financial) leasing with the operating lease.
- Loans (usually convertible fixed interest loans) classified as equity.
- Guaranteed loans, considered as sales (PPAs).
- Non-consolidation of quasi subsidiaries that are used to improve finances enterprise
- Accounting for sales of receivables or factoring depending on the risk arising from non-payment of receivables (non-recognition of liabilities resulting from non-payment of receivables). (Valaskova, Kramarova, Kollar 2015); (Nica, Ionita 2016); (Rahman, Rozsa, Cepel 2018)

#### **2.5. Motives, prevention and consequences**

The most common offenders include managers, owners or employees. First place belong to managers, because in large companies, they are mostly involved. This is sufficiently reflected in the chapter Earnings management. Owners become the perpetrators just in case they are also managers. As for employees, we would rather describe them as intermediaries in the creative accounting activities that are in this paper described.

### 2.5.1. *Motives*

Some kinds of motives have already been mentioned in the Earnings management chapter. It's logical, whereas EM falls under creative accounting. So if we consider it to be superior concept, I will now try to give general motives that society can lead to practice creative accounting in any area. The initiative of managers is a common assumption that if someone already misrepresents accounting information, he does so in order to show the highest profits. But the truth is, and so was indicated in the chapter Earnings management that the motives can be quite different and that the maximum profit does not have to be the main stimulus. Managerial behavior can have several different variants and differs from each other understandably the ultimate goal to be achieved. Many theories state that one of the goals can be proving one's own "usefulness" for society. Of course, it will show how the amount of reported profits, as well as on managers' incomes and side benefits that are given bonus scheme. Political and contractual costs are the main motivation for large and high-profile firms, on the other hand, they may aim to reduce reported profits to be subject to as little regulation as possible. These are the companies known as companies with an almost monopoly position, which is due to too high profits they can be of interest. Further efforts may be to reduce taxes. These are mainly countries with more or less financial and tax accounting. With regard to contractual costs, these are already mentioned several times costs arising from non-compliance. It may be a certain amount of profit, or value of some indicators. The company obviously wants to improve its image of how it is able to pay off debts and get the highest rating possible. Reduction of uncertainty and risk are understandable among many risks in the business environment that are with economic activities inextricably linked. These risks are due to eg transition to exchange rate systems or rising inflation rates. (Siekelova, Kollar, Weissova 2015)

Failed management have some advocates among authors. The theory is, that the expected decline is the driving force behind use of creative accounting practices. Their introduction should delay bad days. Pressure from investors is another factor, because they are trying to meet the stock market demand and attract as many investors can compel the company to use creative accounting. Because creative accounting is still a topical concept and according to some authors can not count on ever disappearing from the business environment, it was published many publications, comments, studies and recommendations that companies should help with this prevent the problem. Of course, because the company itself is at the heart of any kind of creation biasing information about its performance. It is one of the main elements of a functioning market and truthful the information it provides about itself is essential for a proper market environment. (Huynh 2019)

### 2.5.2. *Prevention*

There are several accepted methods of prevention. Adequate control should arise at the company's own initiative and grow comprehensively with the growth of the company. Potential fraud opportunities should be prevented. Corporate Governance it is about setting goals, overall tone, policies, attitudes to risk, responsibility and performance. While prevention would be a desirable outcome of the corporate governance (CG) program, complete prevention is impossible. So intimidation is a much more realistic view. So intimidation is a much more realistic view. CG is an overall culture that sets and monitors expectations of behavior to discourage fraudsters. Another technique is the introduction of ethical culture and ethical standards. The basic duty in the prevention process is related to those who control and lead. Going of course, the owners and managers. They must create the right air, maintain culture honesty and ethical behavior and introduce adequate control to prevent fraud; and errors within the company.

Identification of risk areas is very important part in striving to foster a culture of honesty and ethical behavior is structure risk management approaches. Each organization has specific risk areas that are necessary identify and implement adequate controls. Risk identification depends on the size of the company. A professional counselor can to help identify key areas. (Valaskova, Kliestik, Kovacova 2018)

Setting policies and procedures in the internal control system is one of the most effective ways to investigate and prevent fraud within the organization. In large companies it should be sophisticated a system which should contain documents on the basic provisions of policies and procedures. It should be run by a small team of people, but at least two so that the "Four eyes", that is, mutual control. Now I will focus on internal audit, which is just within the functioning of internal control system very important. (Rybicka, Rybicki 2018)

Internal auditors should be independent of the activities they audit. Professional level of internal auditors, who should have the knowledge, skills and disciplines necessary for implementation internal audits. They should be able to deal with people and have continuous education. (Suprianto, Rahmawati, Setiawan, Aryani 2019) Controls have their importance emphasized in all professional publications. They are like a tool prevention, as well as finding compliance with the measures.

### 2.5.3. Consequences

Obviously, the direct consequence of using creative accounting practices is distortion information. The effects of misrepresentation of accounting information can be categorized by users and economic decisions that are based on them. (Allawi, Mijbil, Salloomi 2019)

It can be said, that the power of impact is determined by the strength of the motive. Creative accounting motives already were described in this paper. But it is important to realize that there is a moral role to play here. The feelings of the main actors and the degree of their satisfaction. Simply put, it has different things for society impact, when managers want to get as much money as possible or make money the dairy cow or, as in earnings management, to some extent in the interest of the company, to improve its position. As it has been already mentioned, the impacts can be differentiated according to users of accounting information such as current and future investors, creditors, business partners, customers, government and its institutions, advisors, financial analysts and the general public. Because each one has a certain field, a chain reaction may occur. Another important aspect may be how much actors will participate in this game with numbers. In the event of the collapse of Enron, the guilty parties also took a ride. So, in the event of consequences, the point is how big it will be disaster and how many relationships in the economic environment can be disrupted.

## 3. RESULTS

Based on the data, an analysis of economic crime in the Slovak Republic and the Czech Republic was carried out. Data are from Slovak enterprises are from statistics of Slovak crime, Czech enterprises are from statistics of Czech crime. The analysis has been carried out over the last ten years. So from 2009 to 2019.

### 3.1. Comparison of creative accounting in the Slovak Republic and the Czech Republic

In this article, we focused on crime rates and average schools in individual countries. Graphical representation is on the graph. 6. The graph shows the rate of clarity and the number of average schools in tic. €.



In the Czech Republic, we first had to convert average schools from their Czech currency to € exchange rates as of December 31. 2019 - 23, 99. Subsequently, the average crime offense for individual years was determined separately.

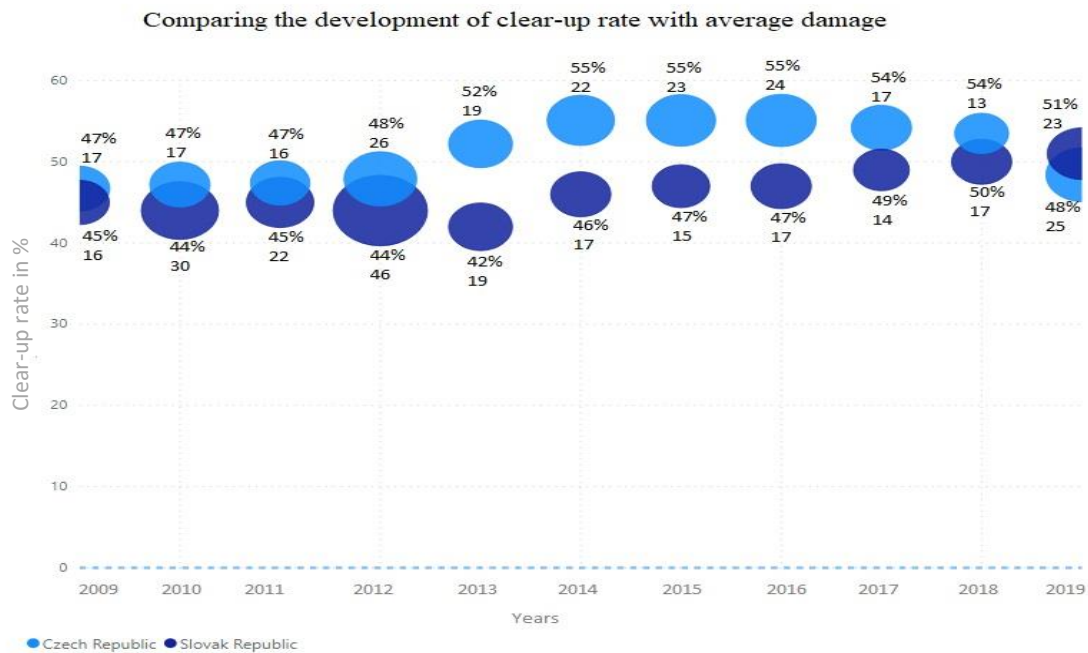

*Figure 1: Comparing the development of clear-up with average damage  
(Source: Own processing according to criminality statistics of the Czech Republic and Slovak Republic)*

It is apparent from Figure 1 above, that the first four years the rate of detection in the Czech Republic was around 47% with an average loss of 17 thousand. €. In 2013, the detection rate rose to 52% with an average loss of 19 thousand. €. Over the next five years, the rate of clarity remained at approximately 55% with an average damage of approximately 22 thousand. €. In 2019, the rate of clarity dropped to 48% with an average damage of 25 thousand. €. In the analysis of Slovakia in the first four years the rate of clarity was 44%, where the average school was 25 crowns. €. In 2013, the detection rate dropped to 42%. In 2014, 2015, 2016 and 2017, the clear-up rate was around 47% with an average damage average of 16 thousand. €. In 2018 and 2019, the rate of detection was around 51%, with an average damage of 20 thousand on average. €.

#### 4. CONCLUSION

Obviously, the direct consequence of using creative accounting practices is distortion information. This area is already described in the fifth chapter on earnings management in the subchapter 'Accounting by accounting item and its effect on information. The effects of misrepresentation of accounting information can be categorized by users and economic decisions that are based on them. It can be said, that the power of impact is determined by the strength of the motive. Creative accounting themes already were described in this work. But it is important to realize that there is a moral role to play here the feelings of the main actors and the degree of their satisfaction. Simply put, it has different things for society impact, when managers want to get as much money as possible or make money the dairy cow or, as in earnings management, to some extent in the interest of the company, to improve its position. As we have already mentioned, the impacts can be differentiated according to users of accounting information such as are: current and future investors, creditors, business partners, customers,

government and its institutions, advisors, financial analysts and the general public. Because each one has a certain field, a chain reaction may occur. Another important aspect may be how much actors will participate in this game with numbers. In the event of the collapse of Enron, the guilty parties also took a ride Arthur Andersen. So, in the event of consequences, the point is how big it will be disaster and how many relationships in the economic environment can be disrupted.

**ACKNOWLEDGEMENT:** *The paper is an output of the science project VEGA 1/0210/19 Research of innovative attributes of quantitative and qualitative fundamentals of the opportunistic earnings modelling which authors gratefully acknowledge.*

#### LITERATURE:

1. Allawi, K. M., Mijbil, S. H., Salloomi, R. K. (2019). The compatibility between lean accounting and cleaner production for achieving competitive advantage, *Polish Journal of Management Studies*, Vol. 20, no. 2, pp. 73-82.
2. Crawely, M., Wahlen, J. (2014). Analytics in empirical/archival financial accounting research. *Business Horizons*, Vol. 57, no. 5, pp. 583-593.
3. Healy, M., Cleary, P., Walsh, E. (2018). Innovativeness and accounting practices: an empirical investigation. *Qualitative research in accounting and management*, Vol. 15, no. 2, pp. 231-250.
4. Huynh, Q. L. (2019). Reputation to the vicious circle of earnings quality and financial performance, *Economics and Sociology*, Vol. 12, no. 2, pp. 361-375.
5. Kamal Naser, H. M. (1993). *Creative Financial Accounting its nature and use*, 1st. edition, Prentice Hall, New York, ISBN 0-13-061763-6, pp. 250.
6. Kovacova, M., Kliestik, T. (2017). Logit and Probit application for the prediction of bankruptcy in Slovak companies. *Equilibrium. Quarterly Journal of Economics and Economic Policy*, Vol. 12, no. 4, pp. 775–791.
7. Marilena, Z., Corina, I. (2012). Embellishment of financial statements through creative accounting policies and options, *World conference on business, economics and management (bem-2012)*, Vol. 62, pp. 347-351.
8. Nica, C., Ionita, E. (2016). Detecting the negative creative accounting practices in companies operating in the romanian market, *Proceedings of the 11th international conference accounting and management information systems (amis 2016)*, pp. 189-197.
9. Rahman, A., Rozsa, Z., Cepel, M. (2018). Trade Credit and Bank Finance – Evidence from the Visegrad Group. *Journal of Competitiveness*, Vol. 10, no. 3, pp. 132–148.
10. Rybicka, K., Rybicki, P. (2018). Chosen aspects of it systems in management and accounting in companies under globalization, *Ekonomicko-manazerske spektrum*, Vol. 12, no. 2, pp. 57-66.
11. Sadaf, R., Oláh, J., Popp, J., Mate, D. (2018). An Investigation of the Influence of the Worldwide Governance and Competitiveness on Accounting Fraud Cases: A Cross-Country Perspective. *Sustainability*, Vol. 10, no. 3, pp. 1-11.
12. Siekelova, A., Kollar, B., Weisssova, I. (2015). Impact of credit risk management. *Procedia Economics and Finance*, Vol. 26, pp. 325-331.
13. Suprianto, E., Rahmawati, R., Setiawan, D., Aryani, Y. A. (2019). Controlling generation of family firms and earnings management in Indonesia: The role of accounting experts of audit committees, *Journal of International Studies*, Vol. 12, no. 3, pp. 3-12.
14. Valaskova, K., Kliestik, T., Kovacova, M. (2018). Management of financial risks in Slovak enterprises using regression analysis. *Oeconomia Copernicana*, Vol. 9, no. 1, pp.105–121.
15. Valaskova, K., Kramarova, K., Kollar, B. (2015). Theoretical Aspects of a model of credit risk determination- Credit risk. *Advances in Education Research*, Vol. 81, pp. 401-406.

16. Vochozka, M., Rowland, Z., Vrbka, J. (2016). Financial analysis of an average transport company in the Czech Republic. *Nase more*, Vol. 63, no. 3, pp. 227-236.

## **DEVELOPMENT OF EXPORT POTENTIAL OF NON-OIL SECTOR OF AZERBAIJAN'S ECONOMY IN THE POST DEVALUATION PERIOD**

**Movlud Farzaliyev**

*Lecturer, Department of Economics and Business Administration at UNEC Business School, Azerbaijan State University of Economics (UNEC), The Republic of Azerbaijan  
movlud.farzaliyev@unec.edu.az*

### **ABSTRACT**

*The main objective of the article is to identify problems and perspectives related to the development of export potential of non-oil sector of Azerbaijan economy during the period following the devaluation. Economic reformations in the country made significant changes in terms of quality and ensured dynamic movement in export. The article contains the analysis of the foreign trade dynamics of Azerbaijan, the current export status of the country's non-oil sector and the changes observed in this direction, export capacity of the non-oil sector, as well as a correlation between production volume and exporting. The article identifies differences between export volumes in non-oil sector before and after the devaluation, and the challenges faced during the management of this process. Sources used by the author includes published scientific research works of well-known national and foreign economists, various scientific concepts, orders of the President the Republic of Azerbaijan, decrees and resolutions issued by the Cabinet of Ministers of the Republic of Azerbaijan, normative-legal acts, and documents of related state programs. Identification of factors influencing export development, explication of specifics and main directions of the state of exporting in Azerbaijan's non-oil sector, analysis of state regulation in modern conditions and studying the applied regulatory framework have been set to achieve in this research paper. The article uses comparative analysis, logical generalization, analogy, synthesis methods. The author puts forward proposals for the purpose of raising the efficiency of state regulation in order to increase exports of the non-oil sector.*

*Keywords: Export, Non-Oil Sector, Incentives, Reformations, Export Potential*

### **1. INTRODUCTION**

The experience of countries with rich fuel and raw material resources shows that the oil factor plays an important role in increasing the competitiveness of the economy in the non-oil sector and exacerbating the problems of developing export potential. Most of Azerbaijan's exports are raw materials. Despite the fact that the volume of export-import operations is growing from year to year, the raw materials oriented nature of exports, as well as the import of many industrial and food products indicate problems in this area. Today, Azerbaijan's efforts are focused on developing the non-oil sector, which will help reduce the national economy's dependence on oil prices. In order to determine the degree of protection of the country from various risks and possible consequences of crises, as well as to form and develop a competitive, diversified economy, the process of creating a solid resource and institutional base is ongoing. Favorable natural and climatic conditions, implementation of state programs on socio-economic development of the regions, rich traditions in food production and export, geographical proximity to potential foreign markets and other such factors show that there are important prospects for increasing non-oil exports. It should also be noted that in the economic literature there are many different interpretations and formulations of "export potential", and, at the same time, there is no universally accepted definition of the methodology for calculating this indicator. When considering approaches to defining the concept of "export potential", emphasis should be placed on its origin and should be defined the terms "potential" and "export". The dictionary of foreign words gives an etymological definition of "potential" (lat. - opportunity, power) - the degree of power, latent opportunities in any respect (Lekhin I. (1979)). The Great

Soviet Encyclopedia defines potential as an available source that can carry out any action or that can be used to achieve certain goals (Prokhorov A.M. (1975)). The issue of export is widely considered in the economic literature. Its general economic definition is given by Paul Samuelson and William Nordhouse. They define exports as goods and services produced domestically and sold abroad, i.e. export consists of the export of goods and services (Samuelson P., Nordhaus W. (1979)). The export potential, according to the definition of the Economic Encyclopedia, is “the ability of all national production, industry, individual industrial sectors or enterprises to produce the required amount of competitive products for export” (Abalkin L. I. and others (1999)). Raizberg B.A., Lozovsky L.M., Starodubtseva E.B. give the following definition: the export potential of a country is the potential opportunity of a country to export its existing or produced resources and products (Raizberg B.A., Lozovsky L.M., Starodubtseva E.B. (2000)). So, based on the existing definitions of the export potential presented in the writings of most economic scientists, we consider it appropriate to present the following generalized definition of this term in relation to the non-oil sector of the economy: “The export potential of the non-oil sector of the economy is the ability of the national economy to produce and sell competitive goods (as well as services, technologies and intellectual property rights) in foreign markets”. It is known that the mechanism of currency regulation through devaluation is one of the important tools in the process of macroeconomic support of export operations. However, in the face of a decline in dollar inflows from oil sales and increased inflationary pressures in the economy of Azerbaijan, the long-term stability of the manat should be seen as a manifestation of the strengthening of the national currency in Azerbaijan, as well as the monetary policy of the state in the context of the global financial crisis. In February and December 2015, the sharp devaluation of the national currency of Azerbaijan - the manat (the official exchange rate of the manat against the US dollar rose from 0.78 AZN to 1.55 AZN, ie about 2 times), as well as in all sectors of the economy, had a serious negative impact on foreign trade, especially on exports. In this case, measures to develop export potential should be implemented, taking into account the strengthening of the national currency. In addition, in resolving the dilemma inherent in raw-exporting countries, such as "preventing inflation or preventing the appreciation of the exchange rate," the government relies on a course aimed at implementing anti-inflation measures in accordance with the Decree of the President of the Republic of Azerbaijan "Strengthening Anti-Inflation Measures". It is known that for the economy, the negative effect of inflation is greater than the negative effect of an expensive currency. Reducing inflation rates increases the price competitiveness of export-oriented industrial sectors. In a sense, the expensive currency stimulates the attraction of foreign investment, which can lead to the modernization of production and accelerated productivity growth. It should be noted that the identification of export potential and maintaining or increasing the export of non-oil products, even in case of force majeure, is one of the most widely discussed issues. The COVID-19 virus pandemic, which is facing the whole world, has once again confirmed this. From this point of view, for the post-devaluation period, our study of the development problems of export potential in the non-oil sector of Azerbaijan is of special importance.

## **2. SPECIFICATIONS OF THE EXPORT SITUATION IN THE NON-OIL SECTOR OF AZERBAIJAN**

For a clearer picture of the state of affairs in the sphere of foreign trade, first of all, we will analyze the dynamics of foreign trade of Azerbaijan as a whole. Of course, the oil sector of the economy has a decisive influence on the current situation of Azerbaijan's export and foreign trade, and the study of the role of the oil factor in this direction is of particular importance. A graphic illustration of the dynamics of Azerbaijan's foreign trade is presented in Chart 1.

The share of imports and exports of goods and services in all forms of economic activity of the republic has changed, and there is a significant increase in the dynamics of export development. If we take 2015 as a transition year due to the devaluation that took place in the Republic of Azerbaijan, then the situation in the field of foreign trade two years before and two years after 2015 is interesting.

**Chart 1.** Dynamics of Azerbaijan's foreign trade turnover in 1995-2019, in million US dollars.

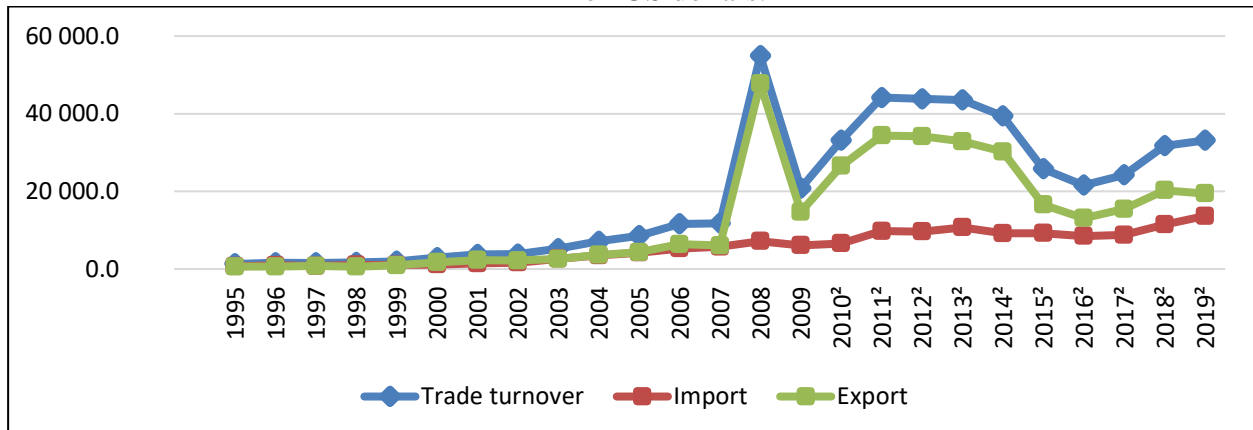

<sup>2)</sup> The statistics are based on the statistically estimated value of crude oil and natural gas actually exported across the country's border, but not fully cleared by customs during the reporting period.

**Source:** Data of the State Statistics Committee of the Republic of Azerbaijan, [www.stat.gov.az](http://www.stat.gov.az)

If the annual foreign trade dynamics of Azerbaijan in 2013 was + 3.4%, in 2017 this figure was + 27.8%. If in 2013 the dynamics of exports was only + 0.3%, in 2017 it was already + 51.1%. Thus, compared to 1995, the share of exports in 2018 increased by 31.8 times, ie in the total turnover, rising from 48.8% to 63.9%. On the contrary, although imports increased 17.2 times for the same period, they decreased from 51.2% to 36.1% in total turnover. However, it is interesting to note that the devaluation that took place in 2015 helped to achieve relative stability in foreign trade - imports and exports, but did not have a significant impact on export growth. The main reason was that the share of the oil sector in exports is still high (Chart 2).

**Chart 2.** The share of exports and imports in the foreign trade turnover of Azerbaijan in 1995-2019.

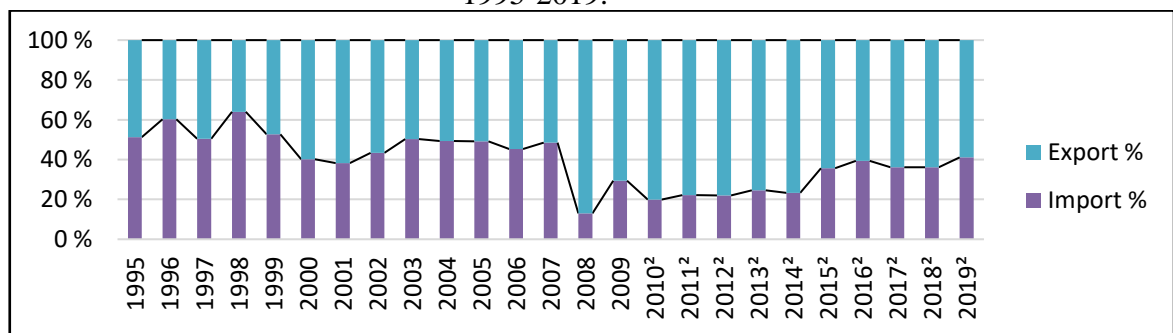

**Source:** Data of the State Statistics Committee of the Republic of Azerbaijan, [www.stat.gov.az](http://www.stat.gov.az)

When studying the geographical structure of Azerbaijan's foreign trade, in our opinion, the following criteria should be adopted as the main ones:

- implementation of the oil strategy - as the "mother" line of integration to the West;
- low competitiveness of domestic manufacturing industry products in the markets of far abroad countries.

The combined impact of the above criteria predetermined a tendentious change in the ratio between the countries of the Far Abroad and the CIS countries in favor of the former. So, in comparison with 1994 in 2019, the ratio between the countries of the Far Abroad and the CIS countries has changed: in foreign trade turnover from 46.8: 53.2 to 86.2: 13.8; in exports from 57.9: 42.1 to 94.0: 6.0, and in imports from 37.5: 62.5 to 74.9: 25.1, respectively.

Similarities in the structure of demand and standards for demand quality parameters, which determine the principle of unequal distribution of resources, as well as the relatively low level of economic development in the CIS in general, determined the dominance of finished products and semi-finished products in export operations with CIS countries. After analyzing the dynamics of foreign trade in Azerbaijan as a whole, let us turn to the analysis of the current situation of exports in the branches of the non-oil sector of the economy. The dynamics of exports in the non-oil sector of Azerbaijan is presented in Chart 3.

**Chart 3.** Dynamics of exports in the non-oil sectors of Azerbaijan in 2000-2019, in million US dollars.

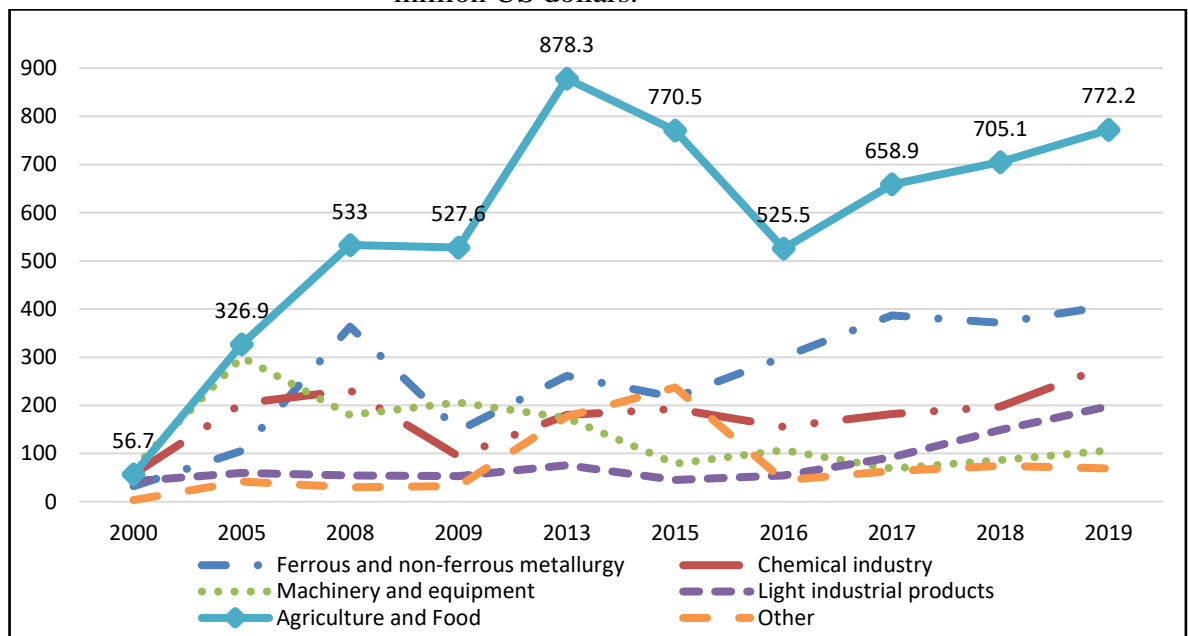

**Source:** Prepared on the basis of statistical publications of the State Statistics Committee of the Republic of Azerbaijan, [www.stat.gov.az](http://www.stat.gov.az)

We divided the study period into three stages:

Stage I - 2000-2008. A steady increase in prices on world commodity markets, on the one hand, and, on the other hand, the active implementation of regional socio-economic development programs and a sharp increase in domestic investment, contributed to a significant increase in the physical and cost volumes of exports in non-oil sectors. At this stage, the value of exports of the non-oil sector increased from \$ 260.3 million to \$ 1393.1 million, or by 435.2%. A significant increase in the value of exports was recorded in almost all branches of the non-oil sector. Thus, exports of ferrous and non-ferrous metals increased 10 times, agricultural and food products - 8 times, chemical products – by 308%, machinery and equipment – by 161%, etc.

Stage II - 2008-2015. The global financial crisis, the almost constant level of foreign and domestic investments, and other factors have caused a reduction in domestic production; and taking into account the deduction of part of the output allocated to satisfy domestic demand, at this stage the value of exports of non-oil sectors increased slightly - from \$ 1393.1 million to \$ 1542 million, or by 10.7%. This increase was provided by the food sector (+ 44.6%), and a number of other industries. In other sectors, there was a significant decline. Thus, export of products in the metallurgical and chemical industries decreased by 40.4%, in engineering - by 56.1%, and in light industries - by about 17%. There were no significant changes in the export of light industry products.

Stage III - 2015-2019. It is characterized as a post devaluation period. Falling world energy prices; decline in their production and consumption; aggravation of the situation in the global financial and currency markets; the two-stage devaluation of the national currency, which caused an increase in import prices and inflationary pressures in the economy, significantly slowed down the development of the export potential of the non-oil sector. The dependence on imported raw materials and components, observed in some sectors of the non-oil sector, in the context of rising prices for imports, contributed to a decrease in the competitiveness of these industries in foreign markets. As a result, in the period from 2015 to 2018, the growth in total exports in the non-oil sector amounted to 2.7%. Particularly sensitive to devaluation were the food sector and the chemical industry. So, in 2016, compared with 2015, the export of food products decreased by 32%, and exports in the chemical industry - by 20%. The relative stabilization of the global economy in 2018-2019 contributed to some improvement in export performance in the non-oil sector. In the period from 2015-2019, the growth in exports of non-oil sectors amounted to 19%.

When analyzing the current state of exports in the sectors of the non-oil sector of Azerbaijan, the analysis of the sectoral structure of export of the non-oil sector, presented in Table 1, is of particular importance.

**Table 1.** Sectoral structure of export of non-oil sectors of Azerbaijan in 2000-2019.

	Stages					
	2000-2008		2008-2015		2015-2019	
	total for the period (in million of dollars)	average specific gravity for the period, in%	total for the period (in million of dollars)	average specific gravity for the period, in%	total for the period (in million of dollars)	average specific gravity for the period, in%
Total	6245,8	100	11774,4	100	7601,6	100
Ferrous and non-ferrous metallurgy	1025,6	16,42	2040,3	17,33	1682,4	22,13
Chemical industry	1273,6	20,39	1592,5	13,52	1010,9	13,3
Machines, equipment	1136,2	18,19	1110,9	9,43	447,7	5,89
Light industry products	435,7	6,98	477,6	4,06	538,6	7,09
Agricultural and food products	2153,0	34,47	5692,8	48,35	3432,2	45,15
Other groups	221,7	3,55	860,3	7,31	489,8	6,44

**Source:** Calculated on the basis of materials of the State Statistics Committee of the Republic of Azerbaijan, [www.stat.gov.az](http://www.stat.gov.az)

The tendency toward an increase in the value of exports in the agricultural and food product sectors observed at all three stages certainly caused an increase in the average share of these industries in the total volume of non-oil sector exports (from 34.47% in stage I to 45.15% in



stage III). The tendency of increasing specific gravity at all stages is also characteristic of the metallurgical industry. The tendency towards a consistent decrease in the specific gravity is characteristic of the chemical industry (from 20.4% to 13.3%) and mechanical engineering (from 18.19% to 5.89%).

**Turning to the study of the influence of oil and currency factors on the development of the export potential of the non-oil sector of the Azerbaijani economy, it should be noted that,** at the beginning of the transition to a market economy, an urgent measure was to identify the locomotive of economic growth in the priority sector. This task falls on the oil sector, both in terms of domestic growth alternatives and in terms of resilience to external competition. The effective combination of external and internal factors of economic growth has ensured high annual GDP growth rates. However, the extensive growth provided by raw material resources may exacerbate the problem of dependence on oil and the formation of a model of unilateral economic development. From a fundamental point of view, in the absence of other alternatives to diversify and increase export potential, the increase in the share of mineral fuels in total exports from 85.1% to 90.1% in 2000-2019 was a natural result of fuel and raw material specialization, and thus 91.2% of the total increase in exports was provided by this sector of the economy. In general, the total volume of foreign direct investment in the economy of Azerbaijan for the period from 2005 to 2018 amounted to \$ 32,275 million, of which 83.4% was directed to the oil sector. The gradual recovery of the economy from the transformation recession, the accumulation of foreign exchange reserves, the expansion of integration ties and the technological reconstruction of production processes have led to an increase in total capital investment from 5.8 billion manat in 2005 to 17.3 billion manat in 2018. The oil sector also attracts a significant portion of domestic investment in fixed assets in industry. Thus, the volume of domestic investments in fixed assets in the field of crude oil and natural gas production during the period covering 2014-2018 amounted to 9388 million manat or 55.7% of the total. It should be noted that during this period, the volume of foreign investment in fixed assets in the field of crude oil and natural gas production amounted to 26291.5 million manat. or 92.7% of the total.

While characterizing the dynamics and sectoral structure of industrial production during the entire period under study, it should be noted that, on the one hand, a significant increase in crude oil production and exports, on the other hand, technological backwardness and the deep gap between the structures of production and consumption in the non-oil sector have determined the raw material orientation of industrial production and the economy as a whole. Thus, if during 2000-2010 the production of crude oil, natural gas and iron ore increased by 250.3%, 366.4% and 604.9%, respectively, and production in the extractive industry (in natural terms) increased by 257%, the growth in the processing industry was only 102% during this period. During 2005-2010, the value of industrial output in the field of crude oil and natural gas production increased by 276%, in the food sector - by 76.8%, in the production of plastic products and rubber - by 84.3%, on the contrary, in the chemical and metallurgical industries - decreased by 39.4% and 17.6%, respectively. As a result, the share of the oil and gas sector in the structure of industry increased from 72.1% in 2000 to 84.6% in 2010. The gradual decline in oil production since 2013 has led to a decrease in the share of the oil and gas sector in the structure of industry in 2018 to 71.8%. To clearly describe the changes in the growth dynamics of the non-oil industry during 2000-2019, it is proposed to read the following graphic illustration.

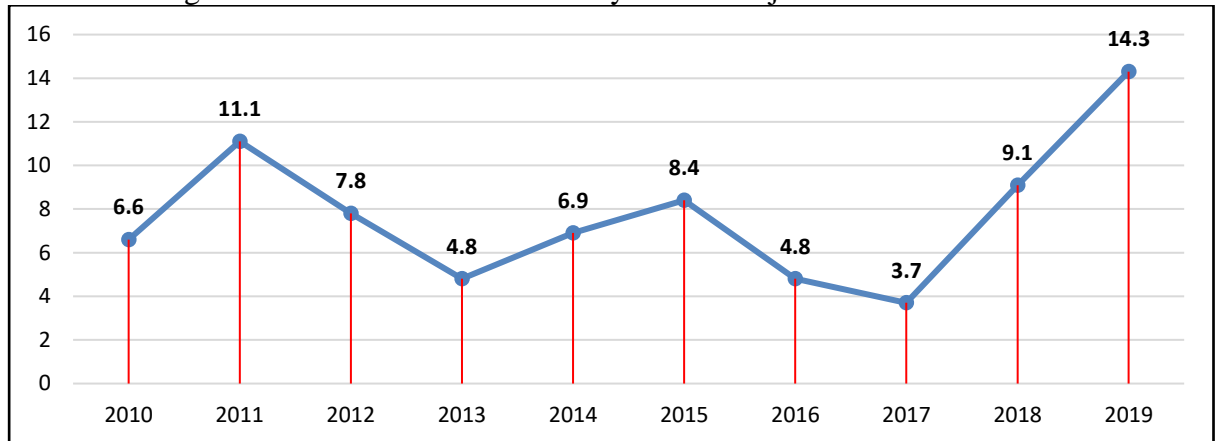
**Chart 4.** The growth rate of the non-oil industry of Azerbaijan in 2010-2019 in %.

**Source:** Statistical indicators of the Ministry of Economy of the Republic of Azerbaijan, [www.economy.gov.az](http://www.economy.gov.az)

In 2019, the total output in the non-oil sector of industry increased by 14.3% compared to the previous year and amounted to 11,321.7 million manat. The non-oil refining industry increased by 18.6% compared to last year. Growth in the non-oil industry in 2019 will be mainly due to wood processing and production of wood products (except furniture) (82.9%), tobacco products (80.7%), production of finished metal products (80.0%), production of computers, electronic and optical products (51.8%), beverage production (41.4%), textile industry products (33.2%), furniture production (29.5%), installation and repair of machinery and equipment (27.5%), chemical industry (25.6%), paper and cardboard production (25.5%), rubber and plastic products (22.0%), food production (10.8%), construction materials production (5.0%), machinery and equipment production (1.0%).

As the main causes of problems in the field of export potential development, which ultimately determined the current state of affairs in this area, the following can be singled out: 1) the rupture of production and trade relations within the USSR and the transformational decline led to a reduction in export potential and the loss of traditional sales markets; 2) technological backwardness, high cost and non-compliance with international standards predetermined the external uncompetitiveness of the economy; 3) the hypertrophied development of the oil sector isolated the mono-structure of exports, and on the other hand, the liberalization of foreign trade at the start of the reform period to eliminate the critical deficit in primary goods then turned into a normal expansion for imports, which in the absence of internal competitiveness was accompanied by a strengthening of foreign products in the domestic market, and strengthened import dependence, including in many sensitive positions for the country (food and light industry, mechanical engineering, etc.); 4) the global financial crisis of 2008 significantly reduced the growth rate of exports of non-oil sectors observed since 2000; 5) the double “devaluation shock” of 2015 also narrowed the export potential of some sectors of the non-oil sector. In studying the relationship between the dynamics of the national currency exchange rate and the dynamics of foreign trade operations in the non-oil sector, we came to the conclusion based on the principle that "the negative effect of inflation on the economy is more effective than the negative effect of expensive currency", that the Government of the Republic of Azerbaijan has led anti-inflation measures by strengthening the national currency to protect the economy from the effects of the global financial crisis, maintain macroeconomic stability and support socio-economic development programs.

The results of the three-stage analysis of the dynamics of the nominal and real effective exchange rates of the manat and the value of non-oil exports in the pre-devaluation period serve as evidence of theoretical considerations about the interaction between the Real Effective Exchange Rate and non-oil exports in Azerbaijan (Stage I - 2000-2004, Stage II - 2005-2007 and Stage III - 2008-2010). In the first stage, which we analyzed above, a 25.8% decrease in the Real Effective Exchange Rate Index (26.2% in the non-oil sector) was accompanied by a 147% increase in non-oil exports, while the oil factor was less effective; the opposite situation was recorded at the second stage. Thus, since 2005, the sharp increase in annual oil production, accompanied by rising world oil prices; high growth rates of foreign investment; as well as the active implementation of socio-economic development programs, mainly due to oil revenues, have led to the excess of foreign currency supply over demand in the local currency market.

**Table 2.** Dynamics of real and nominal effective exchange rates of manat and value of non-oil exports of Azerbaijan in 2000-2019, in% (2000 = 100).

Indicators	Years								
	2004	2005	2007	2008	2010	2015	2016	2017	2019
NEER index	80,2	92,1	85,4	100,1	104,2	89,7	66,3	65,9	72,6
Non-oil sector	91,2	101,8	97,1	117,2	123,2	132,9	96,3	97,3	108,9
REER index	74,2	85,8	95,1	121,8	127,7	110,0	91,3	94,2	99,6
Non-oil sector	73,8	81,4	89,1	114,1	115,3	107,6	86,3	89,8	95,4
Non-oil exports	247,0	388,1	298,8	535,2	476,4	592,3	456,2	558,1	705,1

**Source:** Prepared on the basis of statistical publications of the Central Bank of the Republic of Azerbaijan and materials of the State Statistics Committee of the Republic of Azerbaijan, [www.cbar.az](http://www.cbar.az), [www.stat.gov.az](http://www.stat.gov.az)

In this situation, the Central Bank of the Republic of Azerbaijan (CBA) sterilized the excess part of the foreign exchange supply to a limited extent, thus providing significant support to anti-inflation measures and at the same time expanding the "free floating" limits of the manat against freely convertible currencies. As a result, the Real Effective Exchange Rate strengthened by 10.8% (9.5% in the non-oil sector) and the volume of non-oil exports decreased by 23%. If in the first stage, a 25.8% decrease in the Real Effective Exchange Rate Index (26.2% in the non-oil sector) was accompanied by a 147% increase in non-oil exports, given that the oil factor was not so effective; in contrast, the opposite was recorded in the second stage. Thus, the sharp increase in annual oil production since 2005, accompanied by rising world oil prices; high growth rates of foreign investment, as well as the active implementation of socio-economic development programs, mainly due to oil revenues, have led to the excess of foreign currency supply over demand in the local currency market. The decision adopted within the monetary policy of the Central Bank of the Republic of Azerbaijan on the transition from March 2008 to the dual-currency mechanism at the expense of a currency basket consisting of the US dollar and Euro, made it possible to control the diversified manat rate and neutralize the effect of "import inflation", albeit at the cost of a rise in the Nominal Effective Exchange Rate and the Real Effective Exchange Rate of manat. As a result, the 4.8% appreciation of the Real Effective Exchange Rate of the manat in the third stage was accompanied by an 11% decrease in non-oil sector exports. Looking at the relationship between the Real Effective Exchange Rate and the value of non-oil exports during 2015-2019, which is considered a period of post-devaluation, we see a slightly different picture. Let's look at the main reasons for this. First, the fall in oil prices on world markets and the sharp decline in foreign exchange reserves to keep the national currency stable have resulted in a sharp reduction in lending and dollarization of the economy. Second, the dependence of the production process on imported raw materials and semi-finished products has led to higher prices for imports as a result of devaluation and a decrease in the price

competitiveness of producers. Third, the parallel waves of devaluation in the major trading partner countries have led to economic instability in these countries and reduced their purchasing power. As a result, the opportunities of non-oil exporters to take advantage of the "cheapened" exchange rate effect as a result of devaluation, ie to increase their exports, are completely limited. Thus, in 2016, compared to 2015, in the context of the decline in the Real Effective Exchange Rate, non-oil exports decreased by 23%. Development and implementation of certain programs within the framework of state support to the non-oil sector during the post-devaluation period; as well as the implementation of specific measures in the field of export promotion; revival of lending to the economy; certain stabilization trends in world commodity and financial markets; adaptation of economic entities to "new conditions"; normalization of the situation in the major trading partner countries has allowed to ensure the growing dynamics of exports in the non-oil sector since 2017. In 2019, non-oil exports increased by 26% compared to 2017, in the context of an increase in the Real Effective Exchange Rate.

### **3. DIRECTION TO INCREASE EFFICIENCY OF STATE REGULATION TO INCREASE EXPORTS IN THE NON-OIL SECTOR**

It is known from the world economic literature that exports consist of various economic effects of the state support and stimulation system, measures and tools related to the export organization and information support. These measures include:

- measures related to state regulation at the macroeconomic level;
- measures related to foreign trade policy (protection of certain areas by protectionist methods and methods of international regional integration);
- state participation in export and lending of export-oriented production;
- state participation in insurance of export operations;
- measures related to organizational and information support for export development.

It should be noted that in order to further optimize the application of import-export procedures, the Presidential Decree No. 920 of May 21, 2016 approved the "Rules for the use of" Green Corridor "and other clearance systems for the movement of goods and vehicles across the customs border." In addition, in order to stimulate the export of non-oil products, increase the production and export of competitive non-oil products, access to traditional and new markets, further expand the favorable conditions in this area by Presidential Decree No. 811 of March 1, 2016 has been established a mechanism for financing export promotion and providing repayment support to export products. In order for investors to enjoy the benefits provided by the Tax Code of the Republic of Azerbaijan and the Law of the Republic of Azerbaijan "On Customs Tariffs", on the basis of the Decree of the President of the Republic of Azerbaijan No. 745 dated January 18, 2016 "On additional measures related to investment promotion", the "Rules for issuing investment promotion documents" were approved. The measures are being taken by the state, and the views expressed in this area in recent months confirm this. Thus, taxpayers in the areas directly affected by the COVID-19 pandemic have been offered a number of tax benefits and tax breaks for the period until January 1, 2021: "It envisages the provision of full tax exemptions on property and land taxes, tax exemptions in the amount of 75 percent of income, and other measures." From January 1, 2020 to January 1, 2021, micro-entrepreneurship entities will receive a 50 percent tax credit. In other words, it is planned to reduce the turnover from 2% to 1%, as well as to issue tax breaks for the calculation and payment of taxes and current tax payments (Jabbarov M. (2020)). The main approach in the implementation of export support programs is a comprehensive approach. According to this approach, export support should cover not only the sale of goods and services, but also export-oriented production. However, the number of financial products offered by banks in Azerbaijan today to finance international trade operations is very limited. Some banks generally do not

offer services such as documentary letters of credit, international bank guarantees, and international factoring. As a result, there is a lack of funding for small and medium enterprises (SMEs) to effectively carry out international trade operations, especially export operations. This is due to a number of problems:

- inability of local banks to provide financial products and services to SMEs that are important for international trade and exports;
- lack of competitiveness of SMEs in foreign markets;
- low interest of foreign investors in SMEs;
- loss of solvency of SMEs as a result of improper management of financial risks related to international trade.

World experience shows that along with the development of the export lending system, the establishment of the Export Credit Insurance Institute, which specializes in insurance of export lending services and foreign investment, is of particular importance. In addition, this type of company provides services related to reinsurance and consulting services related to the insurance of foreign economic activity. Thus, the main task of the company for the insurance of export credits is to insure exporters and importers, as well as the banks that serve them from political and economic risks. The most important problems faced by SMEs in international trade operations need to be identified. One of the important directions of state support for exports is a set of information-consulting and organizational-legal measures in this area. It should be noted that the Export and Investment Promotion Fund, established in 2003, gives a big impetus to the process of information and organizational-legal support of Azerbaijani exporters in the non-oil sector. In the early days of its activity, the Export and Investment Promotion Fund dealt only with the problems of attracting foreign direct investment to the Azerbaijani economy; Starting from August 2005, the fund's sphere of activity was supplemented by the promotion of export growth of goods in the non-oil sector. Currently, the database of AZPROMO is used for analysis. However, it should be borne in mind that such institutions are one of the structural elements of the whole system, and it is important to have a working mechanism for financing exports and export-oriented production.

#### **4. CONCLUSION**

Our research on the example of the Azerbaijani economy indicates the significant role of the oil factor in the country's exports. Analyzing the indicators we compared during this period, we came to the following conclusion:

- 2008 global financial crisis significantly reduced export growth rates of non-oil sectors observed since 2000;
- on the one hand, a sharp decline in the country's strategic foreign exchange reserves in order to keep the national currency stable in order to avoid socio-economic tensions before the devaluation and, on the other hand, the decline in the volume of oil dollars entering the country as a result of lower oil prices on world markets have led to a sharp reduction in lending and dollarization of the economy, which has had a direct impact on the decline in economic activity
- 2015 double “devaluation shock” narrowed the export potential of some sectors of the non-oil sector;
- dependence of the production process on imported raw materials and semi-finished products in many areas of the non-oil sector has led to an increase in the cost of products produced here as a result of devaluation and a decrease in foreign competitiveness;
- in parallel, the sharp devaluation processes in the countries of major trading partners (Russia, Turkey, Georgia, etc.), where the products of the non-oil refining industry are exported, have led to economic instability and reduced purchasing power in these countries.

All these processes have led to a sharp reduction in the export-oriented activities of the non-oil sector. Strengthening the policy of state support for the non-oil sector in the post-devaluation period, including the introduction of tax incentives for businesses, the introduction of real financial mechanisms such as export lending, export credit insurance and export promotion, optimal monetary and exchange rate policies led to a positive change in the situation. Increased state support for the development of export potential in the non-oil sector makes it necessary to pay more attention to the following issues:

- improving the institutional framework in the field of financial support for export-oriented production and export activities of SMEs;
- improving the mechanism of awareness-raising support for SMEs in the organization of proper management of financial risks related to international trade;
- implementation of complex regulatory measures to increase the competitiveness of promising export-oriented sectors in the non-oil sector.

#### **LITERATURE:**

1. Approved by the Decree of the President of the Republic of Azerbaijan No. 920 dated May 21, 2016 "Rules for the use of" Green Corridor "and other clearance systems for the movement of goods and vehicles across the customs border"
2. Prokhorov A.M. (1975) The Great Soviet Encyclopedia. Ch. Ed. : A.M. Prokhorov.-M: Publishing House of BSE, 1975.-T 20. p. 428
3. Raizberg B.A., Lozovsky L.M., Starodubtseva E.B. (2000) Modern Economic Dictionary - 3rd ed.; add. –M: INFRA-M, 2000.-p. 407
4. Samuelson P., Nordhaus W. (1979) Economics: translation from English. –M. : BINOM Publishing House, 1997
5. Lekhin I.V. (1979) Dictionary of Foreign Words. ed. Lekhin, I.V. –M. : Publishing house "Soviet Encyclopedia", 1979, - 784 p.
6. Abalkin L.I. et al. (1999). Economic Encyclopedia. Ch. ed. L.I. Abalkin and others. M. : Economics, 1999.
7. Jabbarov M. (2020) Mikayil Jabbarov announced tax breaks.  
<https://qafqazinfo.az/news/detail/mikayil-cabbarov-vergi-guzestlerini-aciqladi-284336>
8. <https://www.stat.gov.az> Materials of the State Statistics Committee of the Republic of Azerbaijan
9. <https://www.cbar.az/> Statistical publications of the Central Bank of the Republic of Azerbaijan
10. <https://www.economy.gov.az> Statistical indicators of the Ministry of Economy of the Republic of Azerbaijan

## ACCELERATING ECONOMIC DIVERSIFICATION IN AZERBAIJAN: CHALLENGES, SHAPING PROSPECTS

**Mushfig Guliyev**

*Azerbaijan State University of Economics (UNEC)*

*Baku, Istiqlaliyyat str.6, AZ1001, Azerbaijan*

*guliyev.my@gmail.com*

### **ABSTRACT**

*This paper, presents an analysis of the sectors that show the largest potential for supporting the country's quest for economic diversification. It draws upon latest information about the diversification of economy and development strategy of oil producers countries from various sources, including research publications and reports provided by international economic organizations (OECD, WB, IMF, ADB, CAREC, EU4 Business programmes and OPEC+). The study assesses the challenges and key constraints of economy, and analyzes key areas in which specific sector reforms can best contribute to economic diversification. The paper also discusses evidence-based policy suggestions that will be useful for the government's future strategies and plans diversifying the industrial base. This paper highlights the importance of foreign investment in supporting SME integration in global value chains (GVCs). Disruptions to global supply chains are one of the clearest effects of the Coronavirus in the world economy. A growing number of researchers expect to change the breadth of their supply chains as a result of the COVID-19 pandemic. Therefore, it is important to act swiftly and in meaningful ways to minimize the fallout from this crisis. As the crisis evolves, complexities and vulnerabilities in global supply chains, which extend beyond role CIS countries in manufacturing and goods trade. Diversification is helping unlock the Azerbaijan's vast resources and human potential. Accelerating economic diversification in Azerbaijan will require strong political will to improve the country's business climate, enhance competitiveness, and increase private sector participation—as laid out, along with the state program of reforms, in Azerbaijan.*

**Keywords:** *Economic Diversification, Integration, Global Value Chains (GVC), Coronavirus, Industrial Zones*

### **1. INTRODUCTION**

Like other emerging and rich developing countries, Azerbaijan has leveraged its abundant production factors to spur economic growth and attract domestic and foreign investment. Over the past decade, the country has positioned itself to take control of a large part of regional project -in particular, in the oil and gaz. Limited by market size and innovations on which to base an economy, the country needed to develop a national plan to attract both domestic and foreign investment to support its growth. Looking back end of XX venture, increased intra-industry trade flows and a rapid expansion of multinational enterprises worldwide have changed the nature of production. In the last few decades a number of globalization and regional integration trends have affected many small economies throughout the world, in particular:

- The rise of global value chains, reflected in an increased fraction of imported intermediate inputs used to produce exported goods;
- A growing number of countries joining regional and multilateral trade agreements, resulting in lower import tariffs and increased FDI;
- A massive decline in transportation and logistics service costs.

Recognizing the importance of the trends is important not only for resetting trade and industrial policy, but also for constructing new measures to capture the international competitiveness of countries.

Azerbaijan has successfully leveraged its core assets—its human capital and strategic industries—to drive its initial economic growth. From the established oil industry to new industries like IT, shipbuilding and Industrial parks, the country has the ability to diversify its sectors and attract new types of foreign direct investment. However, to create the ideal environment for this investment, the government must address certain barriers that have limited both foreign interest and domestic expansion in industry.

## **2. FOREIGN INVESTMENT AND SME LINKAGES IN AZERBAIJAN: CONCEPTUAL FRAMEWORK OF DIVERSIFICATION.**

IMF emphasizes that (IMF 2016), the oil sector cannot be a sustainable source of jobs to absorb the growing workforce. The dominance of oil in oil-exporting Arab economies contributes to shape the economic structure toward energy intensive activities and/or energy dependent services. However, the energy industry, is typically highly capital intensive and generates fewer jobs than other sectors. Because oil is an exhaustible resource, new sectors need to be developed so they can take over as the oil and gas industry dwindles. As indicated above, IMF analysis shows that, even non-oil activities in many oil-exporting Arab countries are to some extent dependent on funding from oil revenues. The challenge therefore is to grow truly self-sufficient non-oil sectors. Despite recent fluctuations in oil prices and the global economic recession, the UAE enjoyed a stable economy.

The policy of economic diversification has led into impressive development in key sectors of economy UAE. The UAE has made progress towards ending its economic dependence on hydrocarbons (government.ae 2020): Oil industries accounted for around 30 per cent of GDP in 2014, down from 79 per cent in 1980. Resource-rich economies such as Kazakhstan, Azerbaijan and Russia, have an excessively regulated economy and a strong comparative advantage in primary products. The more open such economies are, the more extreme their natural resource endowments per worker, and the lower their costs of trading internationally, the more specialized will be their production of tradable and the more concentrated will be their exports on just a few primary products. Inbound FDI in economies in transition declined again in 2018, largely due to falling flows to the Russian Federation, Azerbaijan and Kazakhstan (UNCTAD 2019).

Azerbaijan and Kazakhstan show the greatest increase in export concentration in fewer product groups, in both cases driven mainly by the increase in oil-and-gas prices and in quantities produced . While the extent of Kazakhstan’s export concentration is less than Azerbaijan’s it is much greater than that of the Russian Federation or Australia (Kym Anderson, Giovanni Capannelli, Edimon Ginting 2018).

Currently, Azerbaijan is underway to launch its Road Map for a future after oil. The strategy will include project initiatives for diversifications. It will work to strengthen the competitiveness of the current economic sectors as well as gradually introduce new production sectors, which will achieve a leap in the Azerbaijan economy in accordance with the highest international standards. That would contribute in diversifying the industrial bases of economy and ensuring its sustainability with an emphasis on human capital, knowledge and innovation. Diversification non-oil sectors of economy will provide a sustainable source of growth and employment even when oil resources are depleted (figure 1.). Azerbaijan has opportunities for agriculture to promote economic diversification, and it has the fiscal and infrastructure basis to substantially improve the conditions for sector development. Nevertheless, other sectors – such as chemicals, textiles, furniture, plastic, and metal products – are also important for diversification.



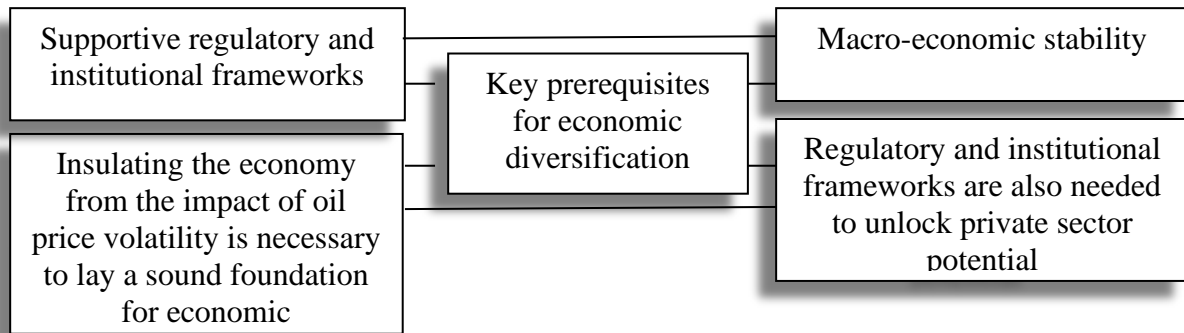

Figure 1. Conceptual framework of economic diversification (grouped by the author)

A closer look at the types of activities of foreign investors that operate in Azerbaijan reveals that the majority of new investment projects are in the services sector (OECD 2019a). It is necessary for Azerbaijan to attract more FDI. FDI helps diversify economy and link it to international production networks. Combining innovation with the right public investments will bring Azerbaijan closer to its goals of becoming exporter in the food processing sector and having a more diversified economy. The development of value chains and export channels a priority, but low coordination among producers and processors has impeded progress. One way of promoting coordination is via cooperation. However, there are also important roles for the government in establishing and enforcing standards and disseminating knowledge. Such measures can contribute to an improved business climate that encourages entry by investors and expanded value-added processing. Azerbaijan, for example, is seen by oil TNC's as a great place to invest, but is also a country where organized both industrial parks and industrial estates with distinct roles and constituencies. Table 1 show that, there are two types of industrial zones In Azerbaijan (industrial parks and industrial estates). Industrial estates are designed to foster supply chain linkages and to create favorable conditions for SME development. SMEs account for over 95% of all established companies in Azerbaijan, but only 10% of value added and 19% of total employment in the non-oil sector (OECD 2019b).

	Created	Industry	Residents
Industrial parks	2011-2016	chemicals, construction materials, machinery, shipyard, recycling, aluminium and steel, light industry, ICT	Foreign MNEs and GLCs, JVs
Industrial estates	2016-2017	automobiles, fish feeds, plastic goods, pipes, paper products, mobile schools	large auto firm, SMEs

Table 1. Operational industrial zones in Azerbaijan: Diversifying the industrial base  
Compiled by the author based on OECD

Note: MNE multinational enterprise, GLC signifies "government-linked company", meaning it is partially controlled by the state. JV signifies a "joint venture" that in this case is partially controlled by a foreign investor,

Industrial estates are a work-in-progress. Considering that the analysis of the specific areas technology and business as the main elements in the decision making process of diversification and the operations strategy, these have to reconcile the technological base with the market demand. The critical feature distinguishing industrial zones from the rest of the economy is the distinct incentives offered to companies operating in the zones (these incentives are generally grouped into two broad categories: tax and non-tax incentives).

Given the vast incentives provided to large conglomerates that locate in industrial parks, it might be desirable to make these incentives more targeted toward linkages with domestic SMEs. As linkages with foreign investors are constrained by a lack of specialist skills, there is significant room for improving vocational and technical skills.

### 3. CORONAVIRUS CHALLENGE ECONOMIC DIVERSIFICATION AND ECONOMIC DEVELOPMENT TRAJECTORY.

Crises are times when governments should reflect on their economic diversification trade relationships and support their firms with a transparent approach. It is a time to pull together and collaborate. We see the focus right now on diversification. The coronavirus outbreak has shown supply-chain disruptions, which can thwart the achievement of an optimum allocation of world resources. Now there is concern, internationally and domestically, as to whether undesirable impediments that could thwart the expansion of world trade. While it's too soon to say whether large-scale sustained adjustments will be made, the change in economic policy caused by COVID-19 worth watching. As the crisis stretches on, and the response evolves, so does the level of uncertainty. Instead, businesses should make a concerted move to diversification. This strategy is needful through hard period of pandemic. Traditional approaches to economic diversification by the oil nations have left them with minimal maneuverability to confront the urgent economic challenges of 2020. CIS oil-nations and other Gulf governments swiftly rolled out economic stimulus packages to shore up their countries' economies (table 2). Therefore, it is incumbent upon the government to provide diversification and package of fiscal stimulus to ignite economic activity that will help the economy regain its footing.

CIS and Gulf oil-nations	Policy responses to the economic crisis
Saudi Arabia	\$13.3 billion to support the private sector
UAE	\$26 billion economic stimulus package
Qatar	\$20.5 billion package of financial incentives for the private sector
<i>Bahrain</i>	\$11.38 billion stimulus package would cover private sector salaries
Oman	\$20.8 billion incentive package for the country's financial institutions
Kuwait	\$1.6 billion of funding for government agencies combating the coronavirus
Azerbaijan	\$47 million to 300,000 individual entrepreneurs
Kazakhstan	\$10 billion package of stimulus measures (together with soft loan programmes and other spending)
Russia	\$18 billion to fight the spread of the coronavirus and its economic fallout

Table 2. How do oil countries differ in their response to the Coronavirus and economic crisis  
Compiled by the author based on [Robert Mogielnicki 2020a]; [News.az 2020a]; [Andrey Ostroukh 2020]; [Olzhas Auyezov 2020].

Even today, there is some lingering dispute about whether such actions really do noticeably good, particularly in resource rich countries. Generally, fiscal and monetary stimuli are thought to have little impact on price levels in the early stages of an economic recovery. This consensus among economists is currently being applied to the stimulus packages designed to offset an economic collapse in the U.S. and Western Europe, occasioned by mandated shutdowns of their economies, related to the fight against the spread of the COVID-19 virus (Edwin T. Burton 2020). But as above indicated, the situation is very different in the spring of 2020 in the oil-produced CIS countries. What is different is that these countries are now experiencing a collapse in output. This type of economic collapse will mean that the stimulus is likely to have the effect that most oil-rich countries seem to be expecting. When to support the private sector where output is constrained, what happens? And what is the theoretical and expected connection between the conditions and the outcome. It is worth a pause to reflect on this situation. It is package of stimulus to offset the fall-off in demand in economies undergoing severe economic contraction. However, will need to act quickly and clearly to ensure that the economy faces a more certain future. In other words, the government needs to engage in sizeable spending in key areas of the economy in order to increase economic activity and to limit the effects on supply chains and the business sector. The low demand arising from cheap oil prices and social isolation caused by coronavirus pandemic does not rule out impacts on Azerbaijan economy. "Life is proving that we must work and live as if we were living in a post-oil era", President Ilham Aliyev said, explaining that now that the price of oil is \$21-22, this is actually a post-era period for us. We have carried out preparatory work for this period and it is still ongoing (Ilham Aliyev 2020). However, the Azerbaijan like in other oil nations has the necessary tools to eliminate the possible negative influences and need use it flexibly. A program of compensating for the damage caused to the entrepreneurs and their employees as a result of coronavirus has been launched in Azerbaijan. The Azerbaijani government rendered financial support in the amount of \$47 million to 300,000 individual entrepreneurs involved in the spheres affected as a result of the pandemic (News.az 2020b). The Gulf states cannot avoid the economic fallout from low oil prices and the coronavirus outbreak, but governments can take decisive steps to make their economies more resilient in the future (Robert Mogielnicki 2020 b). The oil nations have developed several strategies to promote its overall economic and social position and diversify its national income. But though each country must assess their own risk, is unclear as to whether the changes they make will be palpable at the macro and mega level, in particular, developed-developing country partnerships. Countries who may have previously felt sufficiently diversified sourcing from others countries may now seek to build up interregional ties and to look for the ways to institutionalize them optimally.

#### **4. ECONOMIC DIVERSIFICATION AS A MEANS TO ADDRESS THE ADVERSE IMPACTS OF CRISES.**

Falling prices (2015-2020) are a huge problem for all oil-dependent nations. Following the 2014 oil price slump, some countries introduced Value Added Taxes and other reforms to improve economies. The plunge in 2020 in oil prices amid a price war between Saudi Arabia and Russia, and the coronavirus crisis have left plans to diversify the economy of the hydrocarbon-dependent Gulf countries hanging in the air. This is not the first time the Gulf Cooperation Council (GCC) economies have faced oil price challenges, but this comes at a time many are trying to overcome their dependence on oil by boosting other sectors like tourism, education and innovation (Omnia al-Desouki 2020a). OPEC and non-OPEC countries agreed to reduce oil production in three stages from May 2020 to April 2022. Azerbaijan is part of the OPEC+ consultation group and does not exclude a further reduction in its production (created in 2016 to interact with OPEC countries). According to Azerbaijan's Energy Minister Parviz Shahbazov Azerbaijan is likely to support a further reduction in oil production by OPEC and its allies if

this step is necessary to balance concerns about oil demand due to corona virus in China. The mechanism of balancing the oil market with production interventions is supported globally and this support will contribute to the stabilization of the oil market (Trend 2020). It must be noted that Azerbaijan has a stable economic situation, despite its dependence on oil exports. But the fall oil prices in 2020 shows the need for more serious economic reforms. Economic prospects will largely rely on rising gas exports. As much as economists think about risk-taking as a key driver of the economy, an economy only works if risks are largely known. But unknown risks, or uncertainties, can have a larger, more paralyzing effect (Andres Vinelli 2020). Azerbaijan experienced an explosion in growth in the early 2000's as a result of rising oil prices. This growth translated into development as poverty fell and median incomes rose, making it one of the most prosperous economies in the CIS region. When oil prices plummeted in 2014, it also exposed the vulnerability of the economy by over-reliance on oil production. Azerbaijan's economy dependent on oil revenues, which means that Azerbaijan will continue to closely monitor the situation around world oil prices. According to the World Bank's data (World Bank 2019) supported by stable oil production and a modest acceleration in domestic demand, real GDP expanded by 1.4 percent in 2018. While oil production plateaued, the hydrocarbons sector overall posted growth of 1.1 percent, thanks to higher exports of natural gas. But it should be noted the non-energy sector of Azerbaijan's economy expanded by 1.8 percent, reflecting greater dynamism in most economic sectors. The country needs reforms to boost private sector investment, tackle issues of competitiveness. But further efforts are needed reforms the public investment management system in Azerbaijan. How may a heightened risk of uncertainty of oil prices affect the diversification economy? Low prices erode the petroleum revenues that sustain the government budgets of these countries and their economic projects in non-oil sectors. A price war would cause to put the entire diversification plan on hold. A major drop in oil prices would hurt producers around the world, Export earnings of oil produced countries have already been reduced to a trickle, and a further decline would stretch their abilities to pay for vital services and security. The aspiration to become a major regional economic player and international transit hub prompted Azerbaijan in the mid-2000s to invest in the upgrading of its pipeline, road infrastructure, agriculture and industrial base. The high oil price and windfall of recent decades and generous financing from international financial institutions have substantially facilitated implementation of this objective. Azerbaijan's strategic vision in logistics and trade is to achieve the creation of added value for regional transit freight (figure 2).

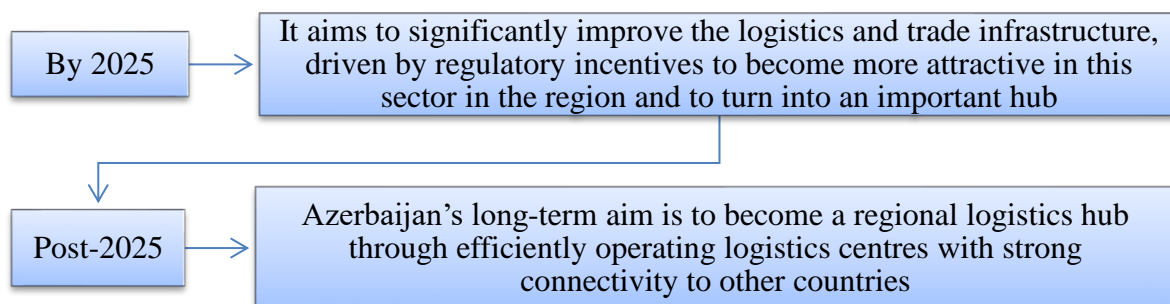

*Figure 2. Azerbaijan's strategic vision in logistics and trade  
Compiled by the author based on EU4business*

The EU supports Azerbaijan in diversifying its economy outside the oil sector, particularly supporting SMEs and encouraging trade. EU4business works with the government, associations and SMEs to develop a more business-friendly policy to contribute to long term socio-economic development (eu4business 2017).

By establishing a series of logistics centre in the country, Azerbaijan aims to increase its share of transit trade in the region, to achieve the following targets (figure 3):

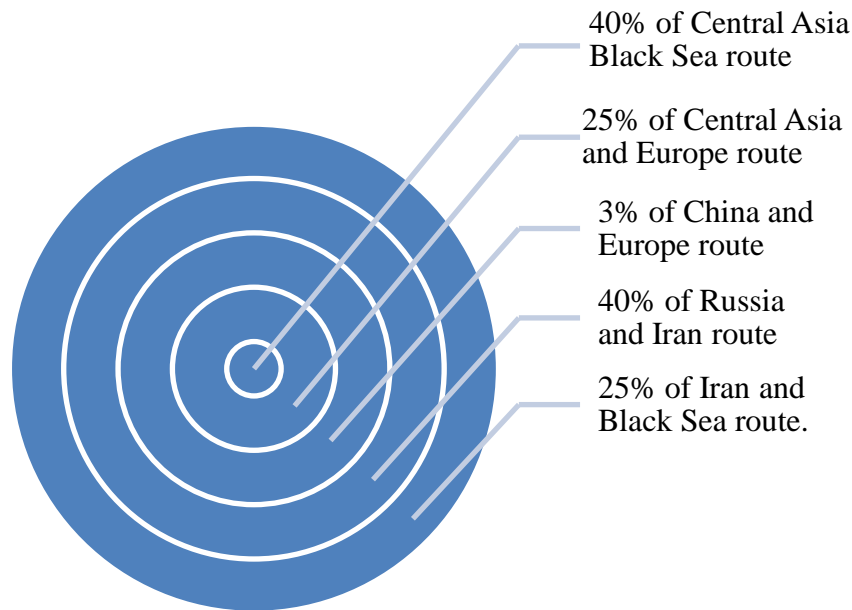

*Figure 3. Azerbaijan: trade facilitation and logistics development strategy  
Compiled by the author based on EU4business*

Turning this potential into reality will require significant improvement in the region's physical infrastructure systems. Azerbaijan joined the CAREC Program (Central Asia Regional Economic Cooperation) in 2003 and key investments have been made in an international transport corridor linking Asia to Europe. Through CAREC, Azerbaijan has been working to make the region into a center of trade and logistic as global markets increasingly integrate. For effective use of the geopolitical potential of the Azerbaijan economy it is necessary of create a trade and transport logistics system, integrated into an international logistics supply chain that can offer quality services at value added. Energy-rich countries who have succeeded in diversifying their economies in the last two decades will have minimum negative impacts, while those who started the economic diversification process in the last decade will need to review and enhance the implementation of their economies (Omnia al-Desouki 2020 b). Most diversification projects are long-term and will not generate additional cash or jobs in the first phase of implementation. But could be difficult to sustain in light of the current crisis. This makes it hard or even impossible to assess the effects on supply chain and businesses disruptions discussed above.

## 5. CONCLUSION

We discussed lessons learned in rich developing country as it transitioned from a resource-intensive economy to one increasingly based on capital and high-skill industries. Based on this example and other countries that have made similar transitions, created a series of recommendations to help form a framework for advancement. Diversification helps realize significant potential by promoting regional cooperation in four priority areas: investment facilitation; trade policy; transport and energy. The recommendations focus on solutions that are practical and applicable to Azerbaijan, and include:

- Improve business environment policies and an incentive, including reducing regulatory barriers to competition is needed for the private sector to grow;
- Develop a investment promotion strategy and advance the accelerating of industrial estates;

- Develop a highly skilled workforce. Labor market reforms and better access to market channels and suppliers chains are also necessary;
- Leveraging FDI to enhance MNE-SME linkages;
- More capacity should be built for innovation and knowledge management, including public investments and a more coherent and effective extension system;
- It is investment in public services and institutional reforms that can provide a long-term basis for productivity growth in the economy, rather than budgetary transfers that favor inefficient production modalities.

Achieving Azerbaijan's potential as a transit economy is essential for the stimulation of non-oil economic development. It includes:

- The transport corridors are building a truly global future for the region, linking markets. As the reintegration of the Eurasian continent gathers speed, Azerbaijan can certainly reap the benefits of diversification and a greater openness in terms of trade development.
- Building inclusive platform to help strengthen cooperation and build synergies with other international and regional cooperation mechanisms.

Implementing the recommendations will allow the country to employ more of the tools necessary to realize its large economic potential and increase prosperity.

#### **LITERATURE:**

1. Andres Vinelli, Christian E. Weller, and Divya Vijay (06.03,2020). The Economic Impact of Coronavirus in the U.S. and Possible Economic Policy Responses. Retrieved 14 .04.20 from
2. <https://www.americanprogress.org/issues/economy/news/2020/03/06/481394/economic-impact-coronavirus-united-states-possible-economic-policy-responses>
3. Andrey Ostroukh. Russia earmarks \$18 billion to tackle coronavirus crisis (01.04.2020). Retrieved 09.04.20 from <https://www.reuters.com/article/us-health-coronavirus-russia-fund/russia-earmarks-18-billion-to-tackle-coronavirus-crisis-idUSKBN21J5VX>
4. Azerbaijan approves new OPEC+ deal (13.04.2020 by Trend) Retrieved 14 .04.20 from <http://www.today.az/news/business/192889.html>
5. Azerbaijani minister: Adopted programs aim to preserve jobs, maintain economic activity (08.04.2020) Retrieved 09.04.20 from <https://www.news.az/articles/economy/147317>
6. Country Context (10.04.2019) Retrieved 14.04.20 from
7. <https://www.worldbank.org/en/country/azerbaijan/overview>
8. Economic Diversification in Oil-Exporting Arab Countries, Annual Meeting of Arab Ministers of Finance (April 2016) Manama, Bahrain. Prepared by Staff of the International Monetary Fund Retrieved 03.03.20 from
9. <https://www.imf.org/external/np/pp/eng/2016/042916.pdf>
10. Economy and Vision 2021. Updated on 19.02.2020. Retrieved 13.04.20 from <https://www.government.ae/en/about-the-uae/economy>
11. Edwin T. Burton The Economics of the 2020 Stimulus Packages (09.04.2020). Retrieved 13.04.20 from <https://www.nationalreview.com/2020/04/coronavirus-relief-economics-stimulus-package/#slide-1>
12. Ilham Aliyev received minister of economy, (31.03.2020). Retrieved 10.04.2020 from <https://en.president.az/articles/36285>
13. Kym Anderson, Giovanni Capannelli, Edimon Ginting, and Kiyoshi Taniguchi.
14. Kazakhstan: Accelerating Economic Diversification. (August 2018), Retrieved 01.02.20 from <https://www.adb.org/sites/default/files/publication/445446/kazakhstan-economic-diversification.pdf>

15. OECD (2019), Azerbaijan: Linking Domestic Suppliers With Foreign Investors, OECD publishing, Paris. Retrieved 13.04.20 from
16. <http://www.oecd.org/eurasia/competitiveness-programme/eastern-partners/Azerbaijan-Linking-Domestic-Suppliers-with-Foreign-Investors.pdf>
17. Olzhas Auyezov. UPDATE 2-Kazakhstan tightens foreign exchange controls to support tenge (23.03.2020). Retrieved 09.04.20 from
18. <https://www.reuters.com/article/kazakhstan-forex/update-2-kazakhstan-tightens-foreign-exchange-controls-to-support-tenge-idUSL8N2BG26I>
19. Omnia al-Desouki Pandemic, slumping oil prices test Gulf economic diversification (02.04.2020) Retrieved 14 .04.20 from <https://www.laprensalatina.com/pandemic-slumping-oil-prices-test-gulf-economic-diversification>
20. Robert Mogielnicki.(19.03.2020).Oil Outlook, Coronavirus Challenge Gulf's Economic Diversification Retrieved 09.04.20 from <https://agsiw.org/oil-outlook-coronavirus-challenge-gulfs-economic-diversification>
21. Strategic Roadmap for development of logistics and trade in Azerbaijan (16.11.2017) Retrieved 14.04.20 from
22. <http://www.eu4business.eu/news/strategic-roadmap-development-logistics-and-trade-azerbaijan>
23. World Investment Report (2019), Special Economic Zones, Retrieved 12.04.20 from [https://unctad.org/en/PublicationsLibrary/wir2019\\_en.pdf](https://unctad.org/en/PublicationsLibrary/wir2019_en.pdf)

# ADVANCEMENT IN GEOECONOMICS THROUGH TOURISM PROMOTION - INTERNATIONAL BEST PRACTICES OF INFLUENCER MARKETING FOR CORPORATE BRAND MANAGERS AND POLICY MAKERS

**Arpad Papp-Vary**

*Dean, Faculty of Business, Communication and Tourism,  
Head of the Marketing MSc programme,  
Budapest Metropolitan University, Hungary  
apappvary@metropolitan.hu*

**Szabolcs Szolnoki**

*PhD Student, University of Pécs, Hungary  
Attaché for Science and Technology, Embassy of Hungary in Tel Aviv  
szabolcs.szolnoki@pm.me*

**Endre Beres**

*Communication and Strategic Marketing Expert, Hungary  
endre.beres@gmail.com*

## **ABSTRACT**

*Geoeconomics represents synergies and an ecosystemic approach where tourism marketing serves the goals of spatial, economic and social development. Influencer marketing has become a hot topic globally in recent years, and the novel corporate practice was also adopted by national and local governments. Since one of its major advantages is multi-platform applicability, it is far more than just another new tool. Given the 'advertising noise', public relations and marketing professionals struggle to find the most effective direct and indirect ways for attracting the attention of the target group. Presenting brand messages in unique narratives involving the power of the opinion leaders' personal voice has proved to be effective in advertising. 87% of surveyed consumers were inspired to make a purchase based on what they saw from an influencer according to Rakuten's cited report. The figures highlight that identifying with influencers increases the audience's openness towards sales-oriented messages. The present study presents international best practices of involving influencers by policy makers responsible for city branding from Eindhoven, Helsinki, The Hague and Miami. Furthermore, it examines the theoretical background and discusses exciting questions. What is the definition of an influencer? How should brands and cities cooperate with them? Why is Instagram an extremely important platform? How can influencers visiting a city (or living there) facilitate city marketing? The authors attempt to provide ideas and inspiration for corporate brand managers and public policy makers already working with influencers or planning to do so.*

**Keywords:** *influencer, city marketing, branding, consumer behaviour*

## **1. WHO ARE INFLUENCERS AND WHY DO PEOPLE FOLLOW THEM?**

### **1.1. An explanation of the word 'influencer' for decision makers**

First of all, it is necessary to define the term itself. According to the Cambridge Dictionary (2020), an influencer is "someone who affects or changes the way that other people behave". Another explanation is "a person who is paid by a company to show and describe its products and services on social media, encouraging other people to buy them". Listed examples in the dictionary illustrate that a person can be an influencer in a micro-community or even within an industry, e.g. fashion and design. The term is also described as a *profession*, referring to a career



path and full-time employment as an influencer. István Sas (2018), a legendary figure of the Hungarian advertising industry said that opinion leaders are '*instrumental figures*' who can have a more powerful effect on others with their openness, vibe and character. Another definition by The Balance Small Business (2019) says that "Opinion leaders have established *authority in a given area, market, or industry*". Some may make a career out of "influencing their audience, impacting their feeling about industry trends and current events, as well as affecting their consumer behavior."

Tamás Joanelli, head of the BeSocial agency says that an influencer is an "opinion leader in a smaller community *who his/her followers believe, therefore they influence the followers' decisions*" (Blog.iab.hu, 2018). In his post 'Who are influencers and what is influencer marketing?', online expert Balázs Máté (2019) highlights that influencers are "*people who have gathered a sizeable follower base around themselves on the internet. Influencer "means someone who influences"*", which is no coincidence, because influencers have the power to shape their followers' opinions and purchase decisions. This is the basis of influencer marketing. According to Influencer Marketing Hub's definition (2019), "opinion leaders have the *unique ability to win people's trust and influence their opinions*. They come up with *original ideas and actionable advice* to help entrepreneurs, businesses, and individuals achieve their personal and organisational goals."

Therefore we can say that opinion leaders are people who are *outstanding members of the community*, because they have personality traits that enable them to influence others' views and shape attitudes. They can stand out from their environment as a result of their unique style, professional knowledge, prestige or extensive network of contacts, which they can use to address and influence groups. At the same time, Interactive Advertising Bureau's glossary on influencers (IAB Hungary 2019) points out that this is not a new phenomenon. Accordingly, "in communication theory, the opinion leader is an influential person – or one considered as such – *who interprets information for others*." The term was first used in a 1955 study by Elihu Katz and Paul Felix Lazarsfeld, who researched the opinion-shaping function of mass media, and found that people's decisions are more influenced by opinion leaders than media.

## **1.2. The power of influencers – their impact on consumer decisions**

Once we have set up categories, it is worth examining *why people follow influencers*. One of the fundamental answers is that they do so because influencers produce *quality content that is interesting for their followers*. As an article by the Márkamonitor magazine (2018) points out, there is an *expectation* that published contents be *entertaining, creative and interactive*.

In October 2017, SAKKOM Interactive agency and Special Media Effect conducted research (Kreatív Online 2017) on the following of influencers. Their most important conclusions regarding data from Hungary may be summarised as follows: *followers of Facebook or Youtube influencers, stars and celebrities are mostly interested in useful, interesting contents (65%) and funny, entertaining videos (48%)* – at least according to the influencers themselves. However, their responses to the question regarding *the most popular themes* of the content they produce show that *funny, entertaining content* is clearly on top with 31%. Rakuten's Influencer Marketing Global Survey 2019 showed that 41% of consumers find at least one new brand or product from an influencer weekly, and 24% say they do so daily. 65% of shoppers discover something of this frequency, therefore brands have many opportunities to reach new consumers via influencers. Only less than one percent of respondents said they 'never' discover a new brand or product via an influencer. The report also says that *87% of surveyed consumers were inspired to make a purchase based on what they saw from an influencer*.

Last but not least, it is worth examining what group is most affected by influencers. Unsurprisingly, it is the Z generation. A survey conducted in Hungary also showed that "online opinion leaders claim that they have the greatest influence on 17-18 year-olds (72.4%), followed by 14-16 year-olds (69%) and 19-23 year-olds (62.1%). These young people like influencers because they are authentic everyday people facing the same problems as their followers. The fans look up to influencers, whose secret lies in directness, personal voice and uniqueness – however, it is also useful if the content produced by them is funny and entertaining." (TanTrend Oktatási Portál 2018).

## 2. COOPERATION WITH INFLUENCERS

As seen above, *one of the best tools to reach the Z generation is influencer marketing*. As the international statistics on the topic highlight (Rgstudio.hu 2018):

- "Influencer marketing offers a huge opportunity in the course of brand building or the introduction of new products, because 71% of Internet users are more likely to make purchases following recommendations seen or read in social media. Moreover, 70% of teenage YouTube users pay more attention to the opinion of the followed influencers than other content published by celebrities.
- The deployment of opinion leaders functions as an *excellent content marketing tool*, because the brand may appear on social platforms as some kind of '*friendly recommendation*'. In addition, via influencers, the brand message may get to followers and target groups who the brand would be unable to reach with traditional advertisements.
- According to TapInfluence's report, 73% of advertisers have a budget separated for influencer marketing. In addition, 86% of them took advantage of the opportunities of influencer marketing in 2017, and 92% of respondents were satisfied with the results of their cooperation. Video posts prove to be the most effective content, and 86% of enterprises use online video content in their campaigns.
- Influencer marketing is also a very *useful tool to increase ROI*. Research has shown that each 1 USD invested results in 6.5 USD investment, therefore the return of campaigns based on influencer marketing performs much better than traditional online advertisement campaigns."

Mátyás Dobó (Doransky), a blogger himself points out that *the essence of influencer marketing is that companies do not communicate with their consumers directly, but influencers deliver messages created for the target group*.

*The value of influencer marketing* comes from 3 sources altogether (Gerillamarketing.blog.hu 2018):

1. *Social reach*: Influencers can reach hundreds of thousands of consumers via their own social platforms and blogs.
2. *Original content*: Influencers produce unique content, which is usually an effective marketing content for the brand.
3. *Consumer trust*: Influencers maintain a strong connection with their audience, who have trust in the influencer's opinion.

*Typical solutions of opinion leader cooperations* have appeared in recent years, although it is a characteristic of the 'genre' that such appearances are always atypical. The advertiser cannot create a word-for-word or image-for-image definition of what it would like to communicate as it would be unnatural, not suiting the blog/vlog or the blogger/vlogger.

### 3. CITY PROMOTION BY BRAND AMBASSADORS

Cities have also started to use influencers in their marketing. A survey by PlaceBrandObserver (2017) found that people engaged in place branding expect that the significance of this tool will increase in the future, and it will become an important way of the cities' promotion and image building. In fact, it is possible to achieve higher reach this way than through some more traditional means of marketing communication today – even if this requires the involvement of multiple influencers at the same time (Econsultancy.com 2018). As an article by millionmetrics.com (2017) points out, the effect of influencers is increased by the fact that users *consider them as some acquaintance or friend*, and view the content of their posts as a *personal recommendation*. Therefore their influence is much greater than that of a traditional marketing communications solution or a traditional celebrity. People are always skeptical if the tourism board of the a city communicates how fantastic its sights are, but they think that it is credible if an influencer does so (Forbes.com (2018). What is more, PMYB (2019), a British influencer marketing agency has also showed – even if in a somewhat disputable way – that *the more influencers you use (including travel bloggers in particular), the more people consider visiting the place*.

In this connection, Development Counsellors International (DCI 2019) goes as far as to highlight that Facebook, Instagram, Pinterest, Snapchat, Twitter and YouTube has revolutionized the way destination marketing organizations must operate.

#### 3.1. Best practice #1: Eindhoven

Eindhoven is a particularly good example that must be mentioned among international best practices. The city is characterized by developed industry and is well known for it, but its cultural and tourism values are less known as a result of its categorization as an 'industrial city'. Therefore, Eindhoven has organized several '*Another city trip*' tours for influencers in recent years. The aim of the tour in 2018 (possibly the best of them) was to get influencers use Instagram Stories to create contents that present Eindhoven authentically. 16 Flemish influencers were involved in Belgium with a total reach of 750 000 people domestic and worldwide. The influencers received a mysterious trip participation opportunity: they boarded a bus in Antwerp, but did not know the destination yet – the only thing they knew was that they would be taken on a 48-hour surprise journey. They realized only after starting the ride on the bus that Eindhoven would be their destination.

Another unique aspect of the 48-hour visit was that the organizers also prepared *personalized programmes besides group events*, and the *customized activities* corresponded to the themes that the influencers usually covered – one of them was taken to a coffee/tea tasting, another to a sewing factory, a third one to a museum, etc. It even happened that influencers could see themselves on outdoor advertising platforms as digital billboards – which of course lead to many posts as they could make videos/photos of themselves, so to speak. The original aim was to make each influencer post 10 Instagram Stories, resulting in a total of 160 posts. By comparison, the result was 511 Stories which were viewed 7.8 million times in total by the influencers' followers. The campaign was widely acclaimed in advertising competitions and awards – it also won two titles at the Influencer Marketing Award in London in the categories 'Best Travel Campaign' and 'Most Creative Influencer Marketing Campaign'. Besides, they outperformed brands such as National Geographic or AXE.

The awards rewards influencer marketing campaigns that *focus on both the brand and the consumer*, are driven by *creativity and innovation*, and set *clear and transparent aims and key performance indicators*. (Eindhoven365.nl 2019a)

During the 'Another City Trip' campaign they achieved the following results: the number of Instagram followers increased by 23.4%, which included a particularly massive attention outside The Netherlands which reached 46%. Eindhoven News reported that they experienced a 124% increase of website traffic from Belgium, and the number of unique visitors grew by 38% (Eindhovennews.com 2019). They achieved this without any payment to influencers – opinion leaders created the contents 'from their heart' and not because they had a contract for it (Innovationorigins.com 2019). More importantly, however, Eindhoven put itself on the map of tourism with this influencer campaign, the jury of the awards said.

During another round of the 'Another City Trip' campaign, they invited 17 international vloggers to present Eindhoven's values to them through many programmes that required their active participation: cycling together, handicraft sessions, market visits and of course the consumption of various tasty foods and drinks. As the video explains, they wished to convey the 'energy' of the city with a dynamic programme of 24 hours. The city marketing department gathered several partners for the project, therefore these appearances helped both the city of Eindhoven and its partners to receive coverage. This Another City Trip campaign also received several awards in competitions such as the contest of the American Content Marketing Institute, the Dutch Interactive Awards or the German Design Award (Eindhoven365.nl 2019a).

As the example of Another City Trip Eindhoven shows, it is very important to have a good 'scenario' for the day or days when the influencers are in the city, which requires the involvement of several partners. It is worth organizing as many active programmes as possible that could provide post topics – unique foods and drinks are always a great theme.

The fourth and latest 'Another City Trip' campaign ran in September 2019. This time, the people 'in the crosshairs' were German opinion leaders – mostly from North Rhine-Westphalia – and of course, their followers. This German region is so close to Eindhoven that it is worth visiting the city for as little as one day, without any overnight stay. It is relatively short distance away, therefore it is easy to get there by train.

The six influencers invited spent 48 hours in the city which they mostly explored by bicycle. Besides targeting German opinion leaders, selection criteria also included people who primarily vlog or blog about design. The result of the weekend was 300 Instagram stories and posts, and there were several interactions by the influencers' followers. At the same time, Eindhoven also started an online marketing and social media marketing campaign in the German region to provide further support for Another City Trip. In the campaign they used Instagram, Facebook, YouTube, Google Ads and native advertising, and their content is also associated with influencers (Eindhoven365.nl 2019b). This is also true because *we might admire a certain city, but we are attached to people, and a combination of the two creates success*. Therefore it is extremely important to include people in advertisements – and this is also true for online advertising.

### **3.2. Best practice #2: Helsinki**

We may also mention another good example: Helsinki, the capital of Finland. The local tourism board called Visit Helsinki invited bloggers, vloggers and instagrammers who created posts about tourism, startups, education and the creative industry. The influencers spent 3-6 days in a studio apartment in the Finnish capital, took part in programmes organized for them, and created content based on their experiences. The name of the initiative was *Helsinki Secret Residence*, and the hashtags they used were #helsinkisecret and #myhelsinkiresidence.

### 3.3. Best practice #3: The Hague

The Hague in the Netherlands opted for a similar solution: *the city furnished a so-called 'blogger house' or 'blogger holiday home' for the off-season period in tourism*, when seaside houses are empty anyway. Bloggers were invited to cover the widest possible range of topics, therefore a great variety of publications were created – and lots of them, as their number is more than a hundred. The solution also won an award: the people behind the idea and the people implementing it were given the Dutch Marketing Innovation Award.

### 3.4. Best practice #4: Miami

Nevertheless, it does not necessarily take a city to organize such campaigns. In the case of Miami, a boutique hotel called Circa 39 undertook this task. As early as 2014, they organized a 'vloggers and vagabonds' event where they invited top Youtubers and asked them to create various contents about Miami. Meanwhile, the Circa 39 Hotel was their headquarters, therefore most of the time it was also featured in the video. Their quality contents still attract new guests to the hotel and the city. (PBMV 2019)

## 4. 'INSTAGRAMMABILITY' – A NEW TRAVEL GUIDE EDITED BY INFLUENCERS

As the example from Eindhoven shows, they expected Insta stories from influencers, that is, Instagram played a prominent role in the project. Of course the city itself must 'comply' when the place is a potential destination – it is increasingly important how '*Instagram-compatible*' it is. A separate term, '*instagrammability*' was created in the international literature for this aspect (Adweek.com 2018). Data revealed that *40% of the new generation considers this a priority* when selecting their newest destination (Forbes.com 2018). Therefore it is more important than aspects such as travel and accommodation expenses, local cuisine, and even the price level of alcoholic drinks available in the city. What is most surprising is that tourist attractions rank last, suggesting that they are the least important aspect.

This means that *it is more important that something looks great on Instagram rather than being a real tourist attraction* – although the two often overlap. In this connection, some people go as far as to say that *Instagram has become a new 'travel guide'*.

### 4.1. Best practice #5: Lake Wanaka

New trends create an *opportunity for less known places to put themselves on the map* as a result of their Instagram compatibility. Examples include Lake Wanaka, a settlement in New Zealand which has been almost completely unknown, but more and more people would like to visit it because of the Insta photos published in social media. All this was no accident, of course: the local tourism bureau invited opinion leaders such as photographer Chris Burkard who has 3.5 million Instagram followers (Cntraveler 2016). As a result of all this, the number of tourists visiting the place has increased at a higher rate than other New Zealand destinations.

It is interesting to see that brand new jobs have been created by tourism bureaus as a result of the importance of Instagram. One of these jobs is '*Instagram drone photo and video professional*' – even if not as a full-time job everywhere.

## 5. RECOMMENDATIONS REGARDING THE ENGAGEMENT OF TRAVEL VLOGGERS AND TRAVEL INFLUENCERS

In 2019 the website of Firebelly Marketing published an interesting post titled '*How To Get Travel Influencers To Visit Your City*'. As the article suggests, the best way is to create a compensation package based on modules which you can offer to influencers based on their overall clout, followers and the social media channels they actively use.

It is important not to offer all the categories below to each and every influencer you contact; it is better to use these categories as a tiered compensation plan.

*Provide swag bags:* As a bare minimum, put together a swag bag for travel influencers visiting your city with local products and branded items that you can only get there. It works as a nice welcome gift for influencers, and gives exposure to products and brands placed in the bag.

*Offer gift cards and discounts:* Most local places will be willing to donate these to you if you tell them they are going to influencers that will talk about them on social media, getting them just as much exposure as the city. Participation in this activity may be especially useful for restaurants and catering facilities, but it may be also interesting for museums, cultural institutions, gift shops, and so on.

*Provide accommodations:* If it takes travel influencers a longer time to get to the city, or they wish to stay for more days, a night or two in a hotel is a great option for compensation. This gives influencers more time to explore the city. This can also be done in cooperation with a specific hotel as influencers will almost certainly create posts about their accommodation.

*Cover incurring travel expenses:* To provide even more compensation, you may also offer to cover travel expenses. This may be especially important in the case of influencers from abroad. In such cases you should calculate petrol costs, bus/train ticket costs or maybe air ticket costs, and offer money accordingly.

*General compensation may also be considered:* When all of the above tools are not enough because you are working with a more prominent influencer, you may offer additional compensation based on the work you are asking them to do. You may add in money on top of the above compensation modules for promised social media posts, blogs, videos, etc. However, as an article by Adweek points out, this must be handled very carefully. Authenticity and credibility are especially important in the case of influencer marketing: if the followers see that the person only posts about the specific place because he/she was paid for it, these posts may backfire on the city. It may be bad for both the city/destination and the influencer if the followers do not feel passion in the content (Adweek.com 2018)

*Encourage return:* A single visit by an influencer may be successful for the city, but consistency, long-term work and some 'repetition' may bring even better results. The destination, for example, might offer a quarterly trip to an influencer, allowing him/her to provide updates on the city and its programmes in each season (PR Daily 2019). Through this, the influencer becomes a kind of city ambassador.

## **6. THE ROLE OF INFLUENCERS LIVING IN A PARTICULAR CITY**

It should be noted that in the case of cities, influencer marketing does not only mean that we invite influencers to visit the city as tourists. In fact, *an influencer living in the city and dealing with the city may be even more important*, as the Brand Urban Agency (2017) points out. In such cases, influencers are a kind of ambassadors for the settlement or a part of it. They are passionate about their city and always take the opportunity to communicate about it. A new term, 'urban influencers' was also created. The point is that these influencers follow the motto 'sharing is caring' and share all the information about their city that they consider important and of public interest. In such cases, the target group may also be tourists, but the focus is more on local citizens as the things that they hear or read in the content produced by the influencers affects their behaviour.

In terms of city marketing, the questions are: 'What makes locals feel good in their city or a part thereof?', 'What makes them live there longer, what justifies their decision?' We may also ask 'What are the things that motivate others to move to the specific city or city part?' – because these things can be authentically explained by a local.

### **6.1. The role of celebrities in city branding**

These influencers may be people who are famous for their professional career. One example is director Danny Boyle, who has many ties to East London – he draws attention to the Shuffle Festival which he is involved in each year. The Spangen neighbourhood of Rotterdam in The Netherlands is popularized by the rap group Broderliefde– they mention the community in almost every interview. International examples also include the Red Hot Chili Peppers whose songs often mention their roots in Los Angeles and the band members also refer to their love for their hometown in interviews. They have referenced the state of California, Los Angeles or Hollywood in at least a dozen of their songs (Louder 2015) and even mention their love for Los Angeles during concerts (Los Angeles Times 2017). Hungarian examples include the hip-hop formation Halott Pénz ('Dead Money') from the city of Pécs, and rapper Sub Bass Monster originating from Gyulafirátót. Besides celebrities, people blogging or vlogging about their beloved city may also shape the reputation and image of a settlement – this includes people who were born or raised in the city and people who moved to the place later and fell in love with it.

### **6.2. Best practice #6: Anchorage**

There are examples when local entrepreneurs initiate a project like this, *asking local citizens to help them make the place more attractive by explaining why they like to live there*. The example of Anchorage (United States) was a great success. Every citizen of the city became an influencer as all of them could send in photos or stories to the Instagram page. Some content created in the 'I love Anchorage' project was later presented in exhibitions across the country, and it also won awards. However, it was more important that they achieved the original goal: they attracted employees and settlers to the city (Brand Urban Agency 2017).

## **7. CONCLUSION**

Brands represent value and influence development opportunities for their owners. The examination of spatial characteristics is one of the first things to do if we assess a corporate or a city. Considerations of economic and social decisions depend on geography. In the case of national and local governments, these actions and policies make up the geoeconomic strategy. Tourism and global image – strongly interconnected in practice but not equal – are much more weighty than shown by figures of statistical reports, e.g. the contribution of travel and tourism to GDP. In times of tight competition for attention and constantly changing consumer behavior, brand managers who do not want to lag behind must keep the pace. The content and its packaging should be unique and customizable. Furthermore, there is a need for experience regarding delivery. Generation Z, the new primary target group of the marketing managers of private and public organizations relies on customer reviews and ratings, not to mention the influencers' recommendations. Their sympathy is measured in likes, comments and shares that can be converted into currencies. The present study introduced best practices as thought-provoking 'appetizers' for corporate brand managers and policy makers already working with influencers or planning to do so. The authors believe that the novel marketing method is even more complex than the well-tried campaigns of the past. As the abovementioned best practices show, brand owners not only need to invest time and money in developing the message and providing it to the influencer (the 'contractor'), but they also need to have knowledge of the influencer and establish a unique connection with him/her to make the story credible.

Investment is important not only financially but also in connection with the influencer and the transformation of a content to make it 'Instagram compatible' and/or rich in unique customer experience. Successful projects prove that the costs and efforts are worth the price by and large. Lake Wanaka, an almost unknown settlement in New Zealand became the country's top tourist destination following the buzz created by social media influencers, similarly to the case of Eindhoven, which is now known not only as an industrial city, and is visited by many because of its tourist attractions and heritage.

## LITERATURE

1. Adweek.com (2018): How Influencers Are Turning the Business of Travel on Its Head (URL: <https://www.adweek.com/digital/how-influencers-are-turning-the-business-of-travel-on-its-head/>, published: 11 May 2018, retrieved: 17 September 2019)
2. Blog.iab.hu (2018): Mégis ki az az influencer? ("Who are influencers then?"), URL: <https://blog.iab.hu/2018/11/19/megis-ki-az-az-influencer/>, published: 19 November 2018, retrieved: 21 September 2019)
3. Brand Urban Agency (2017): Urban Influencers: city ambassadors 2.0 (URL: <https://brandurbanagency.com/en/2017/10/urban-influencers-city-ambassadors-2-0/>, published: 2017, retrieved: 20 September 2019)
4. Cambridge Dictionary (2020): Influencer (URL: <https://dictionary.cambridge.org/dictionary/english/influencer>, retrieved: 26 May 2020)
5. Cntraveler (2016): New Zealand's South Island Sees Tourism Boom Thanks to Instagram Photos Like These (URL: <https://www.cntraveler.com/stories/2016-03-28/new-zealands-south-island-sees-tourism-boom-thanks-to-instagram-photos-like-these>, published: 28 March 2016, retrieved: 21 September 2019)
6. DCI (2019): The Emergence of Digital Influencers and Their Impact on Destination Marketing (URL: <https://aboutdci.com/thought-leadership/digital-influencers-and-their-impact-on-destination-marketing-organizations/>, retrieved: 16 September 2019)
7. Econsultancy.com (2018): How do you market a city? Why place marketers have to be smarter than ever with digital content (URL: <https://econsultancy.com/how-do-you-market-a-city-why-place-marketers-have-to-be-smarter-than-ever-with-digital-content/>, published: 17 March 2018, retrieved: 19 September 2019)
8. Eindhoven365.nl (2019a): Another City Trip Wins Two Influencer Marketing Awards (URL: <https://www.eindhoven365.nl/en/updates/another-city-trip-wins-two-influencer-marketing-awards>, published: 27 March 2019, retrieved: 15 September 2019)
9. Eindhoven365.nl (2019b): (URL: <https://www.eindhoven365.nl/en/updates/german-influencers-are-introduced-to-the-eindhoven-mentality-during-not-another-citytrip>, published: 16 September 2019, retrieved: 21 September 2019)
10. Eindhovennews.com (2019): Local marketing campaign wins international award (URL: <https://eindhovennews.com/news/2019/04/local-marketing-campaign-wins-international-award/>, published: 2 April 2019, retrieved: 15 September 2019)
11. Firebelly Marketing (2019): How To Get Travel Influencers To Visit Your City (URL: <https://www.firebellymarketing.com/travel-influencers/>, published: 1 April 2019, retrieved: 19 September 2019)
12. Forbes.com (2018): Here's How Much Instagram Likes Influence Millennials' Choice Of Travel Destinations (URL: <https://www.forbes.com/sites/andrewarnold/2018/01/24/heres-how-much-instagram-likes-influence-millennials-choice-of-travel-destinations/#7d3c8f1a4eba>, published: 24 January 2018, retrieved: 19 September 2019)
13. Gerillamarketing.blog.hu (2018): Az influencers támadása („Offense of influencers”, URL: [https://gerillamarketing.blog.hu/2018/07/21/online\\_botrany\\_influencerek\\_vs\\_seo](https://gerillamarketing.blog.hu/2018/07/21/online_botrany_influencerek_vs_seo), published: 21 July 2018, retrieved: 26 May 2020)



14. IAB Hungary (2019): Influencer marketing – Fogalomtár (“Influencer marketing – Glossary of Terms”, URL: <https://iab.hu/wp-content/uploads/2019/08/IAB-Hungary-Influencer-marketing-fogalomt%C3%A1r-2019-06.pdf>, published: May 2019, retrieved: 20 September 2019)
15. Influencer Marketing Hub (2019): Top 20 Key Opinion Leaders That You Should Follow (URL: <https://influencermarketinghub.com/top-20-key-opinion-leaders/>, published: 8 August 2019, retrieved: 2 May 2020)
16. Innovationorigins.com (2019): Eindhoven beats AXE and National Geographic when it comes to influencer marketing (URL: <https://innovationorigins.com/eindhoven-beats-axe-and-national-geographic-when-it-comes-to-influencer-marketing/>, published: 27 March 2019, retrieved: 15 September 2019)
17. Kreatív Online (2017): Itt a 10 legbefolyásosabb magyar influencer (“Here are the 10 most influential Hungarian influencers”, URL: [http://kreativ.hu/cikk/itt\\_a\\_10\\_legbefolyasosabb\\_magyar\\_influencer](http://kreativ.hu/cikk/itt_a_10_legbefolyasosabb_magyar_influencer), published: 13 October 2017, retrieved: 19 September 2019)
18. Los Angeles Times (2017): Review: The Red Hot Chili Peppers are still in love with L.A. (URL: <https://www.latimes.com/entertainment/music/la-et-ms-red-hot-chili-peppers-20170308-story.html>, published: 8 March 2017, retrieved: 3 May 2020)
19. Louder (2015): The 13 best Red Hot Chili Peppers songs about California (URL: <https://www.loudersound.com/features/the-13-best-red-hot-chili-peppers-songs-about-california>, published: 16 July 2015, retrieved: 3 May 2020)
20. Márkamonitor (2018): Ősszel jön az influencer fesztivál (“Influencer festival coming up this autumn”, URL: <https://markamonitor.hu/2018/04/23/osszel-jon-az-influencer-festival/>, published: 23 April 2018., retrieved: 18 September 2019)
21. Máté, Balázs (2019): Kik azok az influencerek, és mi az az influencer marketing? (“Who are influencers and what is influencer marketing?”, URL: <https://www.matebalazs.hu/ki-az-influencer.html>, published: 4 March 2019, retrieved: 19 September 2019.)
22. Millionmetrics.com (2017): The Power of Social Influencers in Destination Marketing (URL: <https://www.millionmetrics.com/influencers-destination-marketing/>, published: 26 September 2017, retrieved: 21 September 2019)
23. PMYB (2019): 7 Great Travel Influencer Campaigns that Increased the Sales of Travel Brands! – Influencer Campaigns, Influencer Marketing Tips (URL: <https://pmyb.co.uk/7-great-travel-influencer-campaigns/>, published: 18 March 2019, retrieved: 17 September 2019)
24. PR Daily (2019): Study: Effective influencer marketing requires authenticity (URL: <https://www.prdaily.com/study-effective-influencer-marketing-requires-authenticity/>, published: 24 July 2019, retrieved: 15 September 2019)
25. Rakuten Marketing (2019): 2019 Influencer Marketing Global Survey (URL: <https://go.rakutenmarketing.com/hubfs/docs/2019%20Influencer%20Marketing%20Report%20-%20Rakuten%20Marketing.pdf>, published: 2019, retrieved: 2 May 2020)
26. Rgstudio.hu (2018): Az influencer marketing nyomában (“In the footsteps of influencer marketing”, URL: <https://www.rgstudio.hu/influencer-marketing-nyomaban/>, published: 19 January 2018, retrieved: 15 September 2019)
27. Sas, István (2018): Reklám és pszichológia a webkorszakban – Upgrade 4.0. A kiegyezés kora. (“Advertising and psychology in the web age – Upgrade 4.0. Age of conciliation”) Budapest: Kommunikációs Akadémia Könyvtár.
28. TanTrend Oktatási Portál (2018): Szakma-e az influencer? (“Is influencer a profession?”, URL: <http://tantrend.hu/hir/szakma-e-az-influencer>, published: 11 October 2018, retrieved: 16 September 2019)

29. The Balance Small Business (2019): The Definition and Importance of Opinion Leaders (URL: <https://www.thebalancesmb.com/who-are-opinion-leaders-and-why-do-they-matter-2295976> published: 28 October 2019, retrieved: 2 May 2020.)
30. The Place Brand Observer (2017): 2017 Place Branding Trends, Priorities & Business Opportunities: Survey Findings (URL: <https://placebrandobserver.com/place-branding-trends-priorities-opportunities-2017/>, published: 9 May 2017, retrieved: 18 September 2019)

## ENTREPRENEURIAL ECOSYSTEMS QUALITY: A MULTI-COUNTRY ANALYSIS BASED ON GEM

**Mariana Pita**

*University of Aveiro, Campus Universitário de Santiago, Aveiro, Portugal  
mariana.pita@ua.pt*

**Joana Costa**

*University of Aveiro, Campus Universitário de Santiago, Aveiro, Portugal  
joanacosta@ua.pt*

### **ABSTRACT**

*The interest on entrepreneurial ecosystems has been growing since its recognition as a relevant igniter of entrepreneurial activity. Both scholars and practitioners are aware of the importance of developing favorable environments to promote entrepreneurship, nevertheless, it seems that the ‘perfect recipe’ was not yet discovered. Since countries worldwide are more than ever committed with entrepreneurship-driven policies and practices, it’s of paramount importance to appraise what elements of entrepreneurship ecosystem contribute the most to foster entrepreneurial spirit. Taking the shortage contributions on entrepreneurial ecosystems quality through the lens of time and space, the present study aims to investigate the relation between entrepreneurial ecosystem quality and entrepreneurial activity during a period of 7 years. The study relies on Global Entrepreneurship Monitor Adult Population Survey and National Expert Survey using a multi-country analysis. Findings indicate that entrepreneurial ecosystems tend to be heterogeneous even among countries usually compared as similar evidencing the inexistence of parity among different geographies. Also, the results point that entrepreneurial ecosystems quality is not directly related to a better performance in entrepreneurial activity. At last, the study reveals the importance to build a last long positive perception about the environmental conditions to support entrepreneurship.*

**Keywords:** *Entrepreneurial Ecosystems, Entrepreneurial Activity, GEM, multi-country*

### **1. INTRODUCTION:**

The recognition of entrepreneurship as a crucial driver for development and economic growth (European Commission, 2013) as stimulated the debate around the conditions that properly influence such phenomenon. The literature evidences the importance of entrepreneurial ecosystems (EE) as a set of conditions, usually taken as the exogenous environment, towards entrepreneurship. Several authors attempted to understand the externalities of EE in order to pinpoint the dimensions that influence entrepreneurship, as a way to grasp the ‘recipe’ to create more favourable environments, embolden entrepreneurial activity and create more resilient economies (Spigel, 2017). According to Mack & Mayer, (2016), EE is a bundle of interactive components and players, which enhance new business creation. Xu & Dobson (Xu & Dobson, 2019) refer that EE encompasses in one hand, entrepreneurs, science and technology parks, business incubators, business angels, venture capitalists, and in another hand, universities and academic community, university-industry liaison offices, governmental organizations. This perspective corroborates the work of Reynolds et al. (2005) denoted as the Entrepreneurial Framework Conditions (EFCs) which entailed nine dimensions: finance, government policies, governmental programs, education and training, r&d transfer, commercial and service infrastructures, market openness, physical infrastructures, and at last, cultural and social norms. This model was adopted by Global Entrepreneurship Monitor (GEM) to capture the complexity of EE and appraise the relationship between external conditions and economic development. GEM was conceived to appraising variances in entrepreneurial activity (EA), to disclose its

influences, to remark heterogeneity between countries, and to propose policy packages towards entrepreneurship (Reynolds et al., 2005) based on comparable, reliable and traceable data. Although GEM model undertakes positive relations between EFCs and EA linking external conditions to business creation more empirical contributions are needed (Levie and Autio, 2008), to uncover Entrepreneurship Ecosystem Quality (EEQ). Successful entrepreneurship is been increasingly connected to good EE (Stam, 2015), which has raised the attention to high-growth entrepreneurship within regions (Spigel, 2017). However, good EE could exhibit multiple and diverse configurations influenced by national trajectories, highlighting the importance of having comparative studies that focus not only on the outcome (entrepreneurial activity) but rather look to the attributes that constitute the EE (Spigel, 2017), based on time and space. The present study aims to provide contributions to answer two questions: *how entrepreneurial ecosystem quality relates with entrepreneurial initiative* and *what EE conditions are prevalent in countries with higher EA*. These questions will shed the light on EEQ diversity and will allow to perceive EE parity along its effects, expand the understanding of EE. Departing from prior contributions of Levie and Autio (2008), the study provides an empirical multi-country analysis based on GEM EFCs, using a panel approach comprising 22 countries, from 2010 and 2016. Findings evidences that EEQ is not directly related to a better performance in terms of EA. Also, the results reveal that EE tend to be a heterogeneous phenomenon and, surprisingly, in countries with higher EA, there is a shortage of infrastructures support and the inverse is also true. Overall, the present work contributes to extant EE literature opening the concept of EEQ and evidencing an unbalanced influence among EE factors, and ultimately, demonstrate that EA does not result from “one size fits all” strategy.

## **2. ENTREPRENEURIAL ECOSYSTEMS: A CONCEPTUAL OVERVIEW OF ENTREPRENEURIAL ECOSYSTEM QUALITY**

Entrepreneurship has been a topic broadly discussed since its recognition as a powerful driver to foster economic growth, employment and innovation which has instigated a number of studies devoted to understanding the externalities upon entrepreneurial activity. It is important to acknowledge that EE approach, just like strategy and regional development studies, underlines the interdependence between actors and factors and sees entrepreneurship as an output (Acs et al., 2017). More, it is expected that all actors engaged in EE enrich and sustain their performances breeding national economic performances. Following this perspective, the scope of EE gains a broader dimension, placing entrepreneurs and other players as crucial to determine the pathway of entrepreneurship development. As defended by (Roundy, 2019) EE is induced by business externalities at large, involving also non-entrepreneurial actors. EE evolve as a result of dynamic changes along time and spacial boundedness. The creation of EE follow different pathways and can emerge from places with a highly regarded knowledge base (Brown & Mason, 2017), however, cannot be promptly implemented and holds years of continuous efforts (Mack & Mayer, 2016). As a result, the studies tend to rely on countries with more stable ecosystems and high-growth ventures (Xu & Dobson, 2019), leave-taking “places that don’t matter” (Rodriguez-Pose, 2018). For Xu and Dobson (2019) “peripheral places”, frequently struggles with the lack of social, cultural, critical thinking and economic resources, which constitutes more modest levels of EEQ when compared to more advanced ‘scale-up ecosystems’ (Brown & Mason, 2017). The work of (Brown & Mason, 2017) offers a conceptualization of entrepreneurial ecosystems based on four coordinative characteristics of EE namely entrepreneurial actors, entrepreneurial resource providers, entrepreneurial connectors and entrepreneurial culture. Just as other studies devoted their attention to individuals, also in this case, the entrepreneur is acknowledged as a basilar element of EE along entrepreneurship supporters. The system is also composed by entrepreneurial supply sources (private and public) underpinning business growth and upscale. The model additionally

pinpoints the importance of entrepreneurial connectors as the orchestrators of knowledge valorisation and business development. Lastly, entrepreneurial culture is considered a leverage to enhance entrepreneurship. Nevertheless, it does not mean that more developed countries show higher propensity to enterprise. The dimensions on the study conducted by Brown & Mason (2017) are embedded in the framework adopted by GEM, reinforcing its importance to address EE. The contribution of (Reynolds et al., 2005) and (Levie & Autio, 2007) were of paramount importance to obtain a model that allowed envisioning countries context through the lens of nine exogenous factors: finance, government policies, governmental programs, education and training, r&d transfer, commercial and service infrastructures, market openness, physical infrastructures, and at last, cultural and social norms. Governmental programmes and commercial and legal infrastructures are taken as business services necessary for entrepreneurial projects management. It is expected that greater quality on government programs and infrastructures induce higher levels of entrepreneurial activity. Regarding education and training, the authors posit that higher level of education and training for entrepreneurship in a country, the higher level of entrepreneurial activity echoing several studies devoted to appraise the effect of entrepreneurship education on entrepreneurship propensity (Fayolle & Gailly, 2015). Concerning entrepreneurial culture and social norms, aligned with previous studies (Breazeale et al., 2016), Levie & Autio (2007) recognizes that entrepreneurship cannot be comprehended apart from context and results from culture. Therefore, the authors argue that countries with more favourable entrepreneurial culture faces higher levels of entrepreneurial activity. Finance is another dimension, usually taken as a vital instrument used to develop business. There are several studies pointing that financial constrains hamper entrepreneurial activity (Ghosh et al., 2018), particularly among women. As so, more easy access to finance will allow to increase entrepreneurial initiative. EFCs also comprises market openness as a driver of entrepreneurial activity, since the model assumes that market dynamics stimulate the emergence of new business opportunities (Atilla Öner and Kunday, 2016). Based on the work of Audretsch et al. (2012) EFCs emphasis the role of technology transfer and R&D in fostering innovation and creation of entrepreneurial businesses. Assessing physical instar-structures is also seen as an “input-completer” (Levie & Autio, 2007) and a driver of entrepreneurship. At last, government policies are seen as an echo of supra-national organizations with the purpose to ignite entrepreneurial spirit both globally and locally (European Commission, 2013). Is, therefore, posit that government policies positively influence entrepreneurial activity. In sum, GEM argues that entrepreneurship dynamics can be linked to conditions that enhance (or hinder) new business creation (Bosma & Kelley, 2019). Following the prior contributions and considering that EE with higher levels of quality in its dimensions, induce higher levels of EA, the present study proposes the conceptualization of EEQ. The focus of EEQ is to provide an overall perspective of EE grounded on weighted dimensional influence. In that way, it will be possible to outline EE valuation based on the dichotomous analysis of EEQ and EA.

### 3. METHODOLOGY

Although the rich contributions in the field of EE, there is still a gap of empirical findings that allows to examine whether EE dimensions impact and if differ according to geographical routes. The present work relies in GEM database, along a timespan of 7 years (2010-2016), exploiting a balanced panel approach comprising 22 countries. Given the multidimensional complexity of the phenomenon and for the study purposes, the conceptual thinking around Entrepreneurial Ecosystem Quality is based on the aggregated data extracted from EFCs. All dimensions are computed by means and EEQ represents the ponderation of variables for each country, per year. To assess EA, Adult Population Survey (APS) was used and means were computed for each country, per year. Limitation in data collection periods, as well as missing data, restricted our

sample, since the implementation of a panel approach implies longitudinal data. To assess EEQ, nine dimensions were examined following the EFCs model proposed by GEM: Funding measures (FME), Government Policies (GPO), Government Programs (GPR), Education and Training (ETR), Research & Development Transfer (RDT), Commercial and Services Infrastructures (CSI), Market Openness (MOP), Physical Infrastructure (PIN), Cultural and Social Norms (CSN). The conceptualization of EEQ is the product of an equitably contribution of all nine variables. After, EEQ is connected with EA for the 22 countries. A time-space evolution of these dimensions is presented and the eventual existence of structural differences between countries and their continuity over time is discussed to appraise what exogenous conditions are more related with EA

## 4. RESULTS AND DISCUSSION

### 4.1. Entrepreneurial Ecosystem Quality: a general overview

When comparing the EEQ along the 7 years (Table 1), despite the central tendency, several countries confirm a positive evolution as the cases of Greece, Spain, Switzerland, Sweden, Chile, or Portugal. Though, Greece, Spain and, Portugal expose a more noteworthy alteration probably due to the recovery efforts after the financial crisis phase. In the opposed, Germany, Peru, Mexico, Croatia, Slovenia, Uruguay and, Taiwan reveal an inverse performance with 2010 showing better results than 2016 (Figure 1). In the overall, the EE are perceived as poor or satisfactory, with the exception of Switzerland, Finland, Malaysia, and Taiwan. For the other countries, efforts to create an entrepreneurial ecosystem are less balanced among all variables displaying a tendency to develop infrastructures, physical and commercial services, overlooking other dimensions. Unexpectedly, countries with robust EE – as the cases of Switzerland or Finland - do not exhibition better EA when rivalled to those foulest placed which is the case of Peru, Chile and, Colombia. Those three countries expose that beyond 20% of individuals select to initiate business activities but Peru stands with an impressive 36,6%. Further countries such as Mexico, Argentina, Brazil, or South Africa get around 10% of EA, notwithstanding the role of institutions and policies being short. Another notable conclusion relates to national culture towards entrepreneurship, proposing that cultural norms could postulate a solider influence when paralleled to other dimensions. Separately from these cases which are located above the average, the other EEs are generally considered as satisfactory. The results show that EFCs experts tend to use central evaluations, demonstrating a harmonised and conventional outlook about the environmental conditions.

Country (Code)	2010	2011	2012	2013	2014	2015	2016	EEQ
South Africa (27)	2,47	2,51	2,49	2,60	2,57	2,47	2,50	2,52
Greece (30)	2,30	2,36	2,22	2,42	2,42	2,30	2,44	2,35
Spain (34)	2,48	2,43	2,63	2,42	2,68	2,59	2,68	2,56
Hungary (36)	2,41	2,44	2,65	2,79	2,69	2,38	2,55	2,56
Switzerland (41)	3,26	3,49	3,50	3,43	3,44	3,58	3,40	3,44
United King. (44)	2,80	2,83	2,97	2,89	2,85	2,93	2,67	2,85
Sweden (46)	2,67	2,92	2,85	2,87	3,02	2,93	2,93	2,89
Germany (49)	3,06	3,04	3,04	2,96	3,00	2,86	2,92	2,99
Peru (51)	2,64	2,65	2,74	2,51	2,53	2,37	2,49	2,56
Mexico (52)	2,95	2,67	2,60	2,81	2,58	2,80	2,82	2,75
Argentina (54)	2,58	2,52	2,71	2,72	2,59	2,48	2,55	2,59
Brazil (55)	2,45	2,45	2,39	2,81	2,35	2,26	2,31	2,43

Chile (56)	2,64	2,78	2,78	2,78	2,82	2,81	2,82	2,78
Colombia (57)	2,83	2,46	2,77	2,79	2,70	2,56	2,69	2,69
Malasya(60)	3,10	2,86	3,25	3,11	3,23	3,33	3,09	3,14
Portugal (351)	2,60	2,77	2,60	2,90	2,91	2,91	2,88	2,79
Ireland (353)	2,87	2,95	3,00	2,99	3,02	3,20	2,93	2,99
Finland (358)	3,15	2,90	3,07	3,11	2,96	2,98	3,13	3,04
Croatia (386)	2,59	2,50	2,39	2,44	2,40	2,20	2,25	2,40
Slovenia (598)	2,73	2,61	2,63	2,55	2,46	2,61	2,63	2,60
Uruguay(886)	2,75	2,66	2,83	2,80	2,65	2,59	2,50	2,68
Taiwan	3,33	3,25	2,92	3,01	2,94	2,85	2,98	3,04
EEQ	2,76	2,73	2,77	2,81	2,76	2,73	2,74	2,76

Table 1. Entrepreneurial Ecosystem Quality (2010-2016) for 22 countries

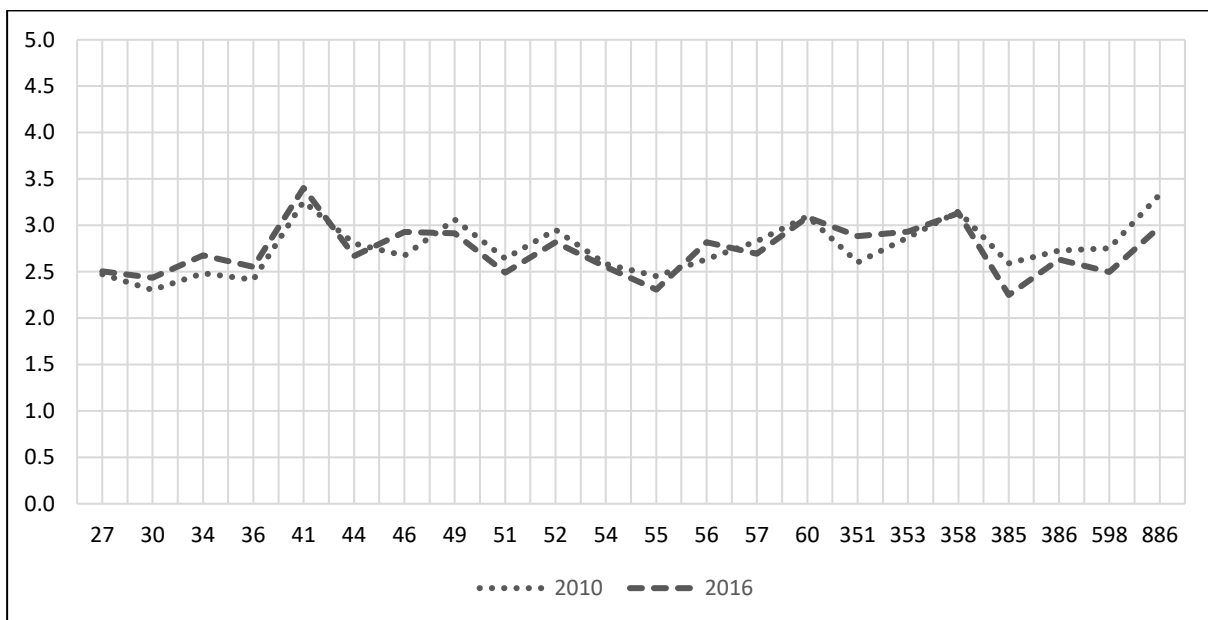

Figure 1. EEQ between 2010 and 2016, per country

#### 4.2. Entrepreneurial Ecosystem Quality and Entrepreneurial Activity: a multi-country analysis

To provide a more detailed perspective about entrepreneurial ecosystem dimensions, between 2010 and 2016, it was performed a comparison between the nine variables among countries.

The first look over the data mark dissimilarities among variables, with Physical Infrastructures as being the strongest dimension of EE, as proved by several countries, such as Hungary, Sweden, Germany, Peru, Argentina. With a contrasting representation, Government Policies, Education and Training along with R&D Transfer display a weak performance, as the cases of Colombia, Croatia, Ireland, or Chile. In terms of EA, non-European countries uncover higher vitality attaining near twice the rate of business creation, such as Peru, Chile, or Colombia. This is in line with prior studies that advocate a prevalence of EA in less developed economies. The dimension Funding Measures presents higher relevance for Switzerland, Malasya, Finland or Taiwan (Figure 2). For ten countries, there is a positive growth of the variables, while in eight countries it is verified a reduction. For instance, Hungary and Ireland reports a sharp growth whilst others expose a moderate transformation.

Concerning government policies, several countries present a consistent behaviour without significant transformations between 2010 and 2016, such as Greece, Hungary, Brazil or Portugal (Figure 3). However, 50% reveal a negative propensity to withdraw governmental policies towards entrepreneurship. Consistently with prior results, also government programs face a decrease between 2010 and 2016, for eleven countries, representing 50% of the sample (Figure 4). It is notable to verify that Switzerland and Germany posit over the average presenting the highest values, along with other ten countries although with more moderate profiles. The results indicate Education and Training as one of the weakest dimensions with countries reporting between poor and satisfactory performance (Figure 5). Only five countries (Hungary, Switzerland, Sweden, Malaysia and Portugal) strengthen their education and training system, between 2010 and 2016, to better prepare individuals towards entrepreneurship. For 50% of the cases, ETR was confronted with a decline of investment. Regarding Research and Development Transfer (Figure 6), the results show that 36% of countries had a positive transformation between 2010-2016, such as Greece, Spain, Hungary or Switzerland. However, more than 50% of cases are reported as partaking a decrease in this dimension. It is also notable that only Switzerland is positioned above the average in both periods.

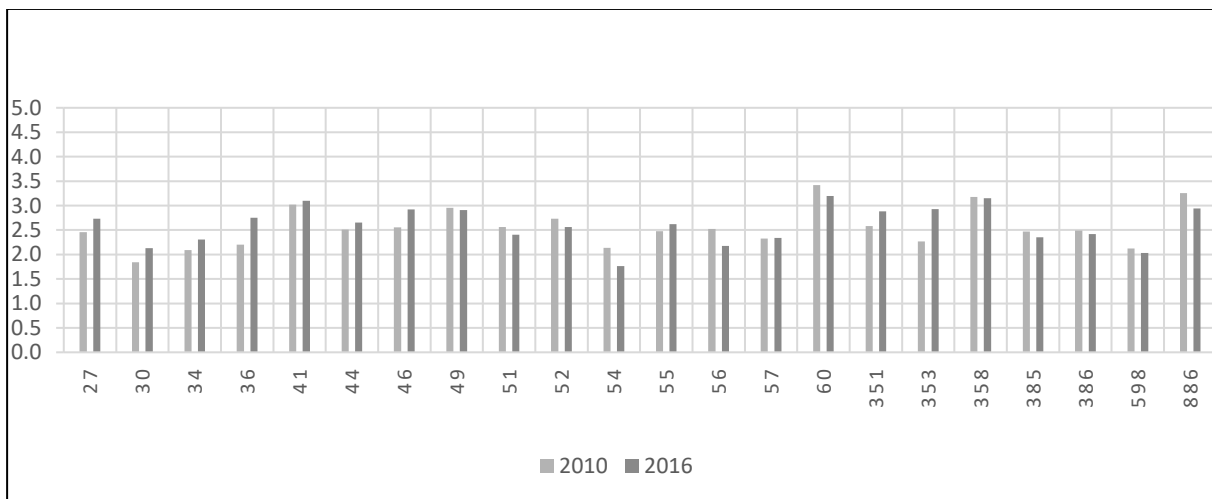

Figure 2. Funding Measures between countries in 2010 and 2016

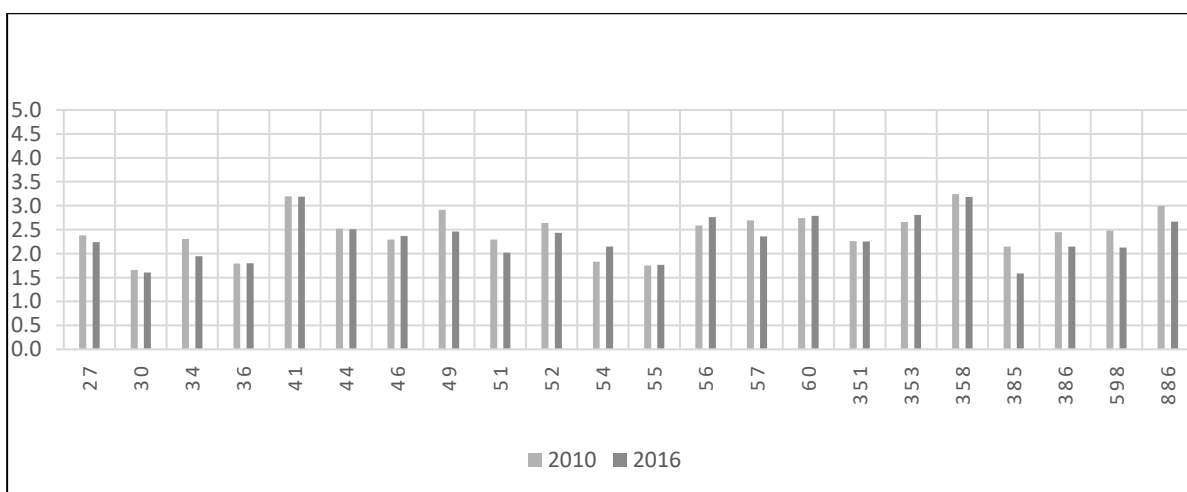

Figure 3. Government Policies between countries in 2010 and 2016



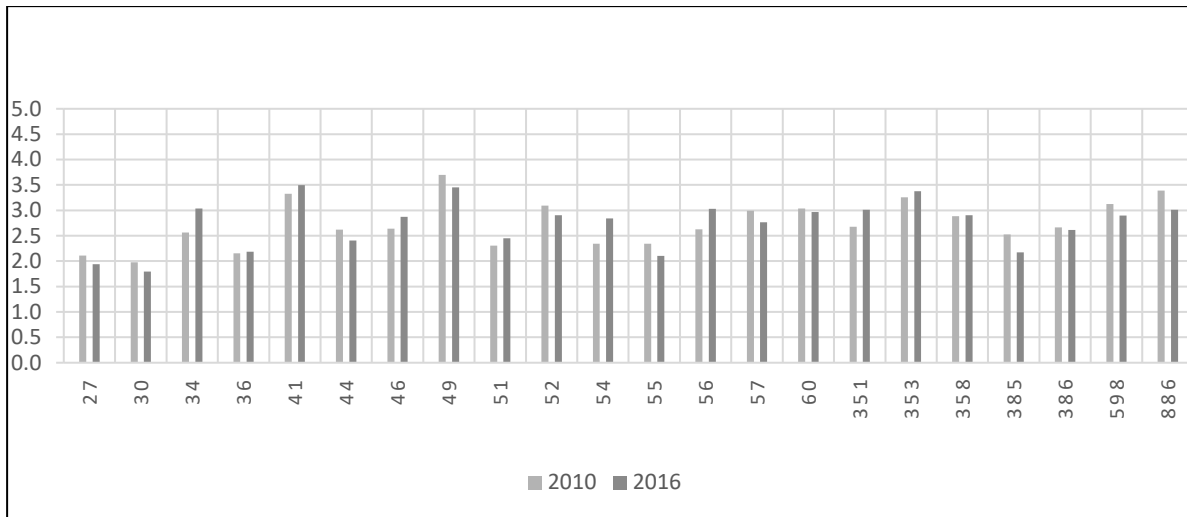

Figure 4. Government Programs between countries in 2010 and 2016

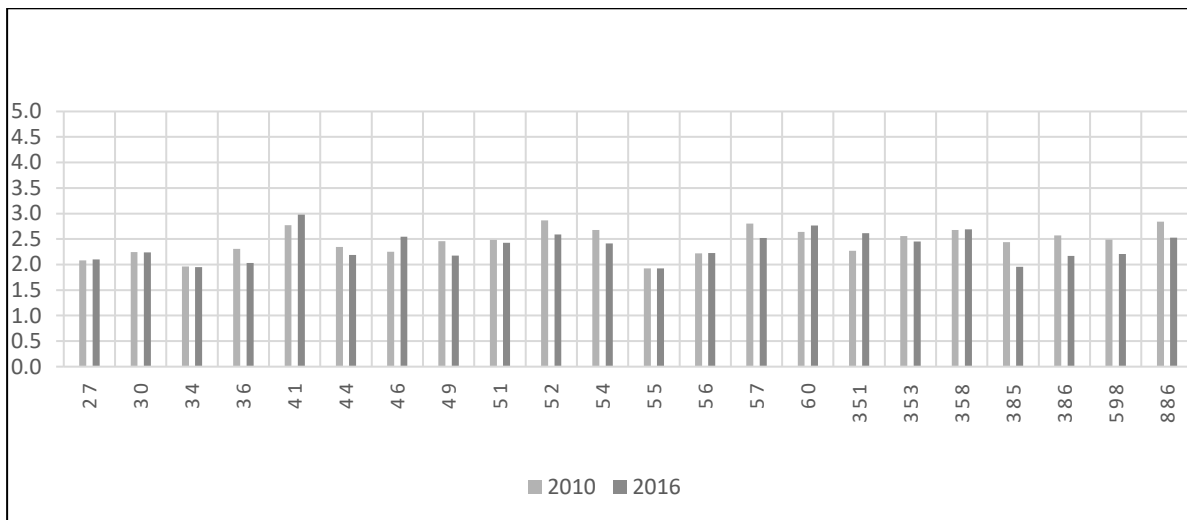

Figure 5. Education and Training between countries in 2010 and 2016

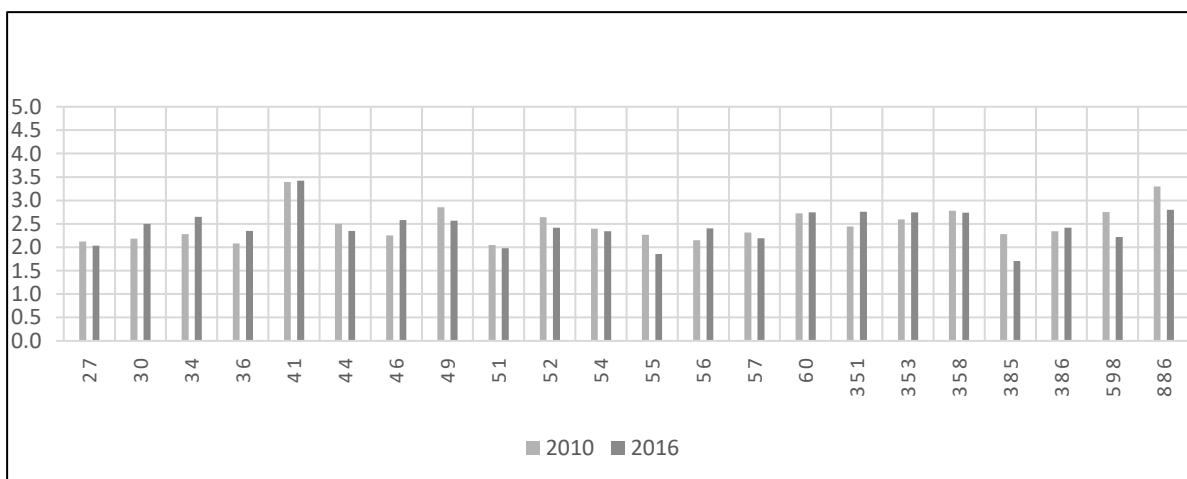

Figure 6. Research and Development Transfer between countries in 2010 and 2016

Commercial and Services Infrastructures are measured above the average in most of the cases (Figure 7). Only ten countries evidence a progressive change, with Switzerland, Germany and Portugal taking the lead. In a contrary position, Peru and Brazil emerges as those with poor infrastructures. Similar to prior dimensions, market openness presents a satisfactory evaluation at general, with only two countries (Malasya and Taiwan) exceeding the average (Figure 8). Only 36% of countries attain a positive evolution towards a more friendly business environment. Surprisingly, Portugal and Uruguay could be considered as followers once they exhibit a market with superior constrains. Physical infrastructures emerge as the strongest dimension of entrepreneurial ecosystems, evidencing the efforts on providing good access to basic utilities and support business activities (Figure 9). More than 40% of the countries evidence a positive transformation between 2010 and 2016. In a descendent movement, Argentina and Brazil represent the cases with utmost significant decline. The last dimension, Cultural and Social Norms (Figure 10) presents a larger amplitude with countries, in one hand, positioned clearly below the average (as for Slovenia or Uruguay) and others, in second hand, placed strongly above the average (as Switzerland and Taiwan). During the timespan, only eight countries reveal a positive growth, showing a certain heterogeneity among the variable.

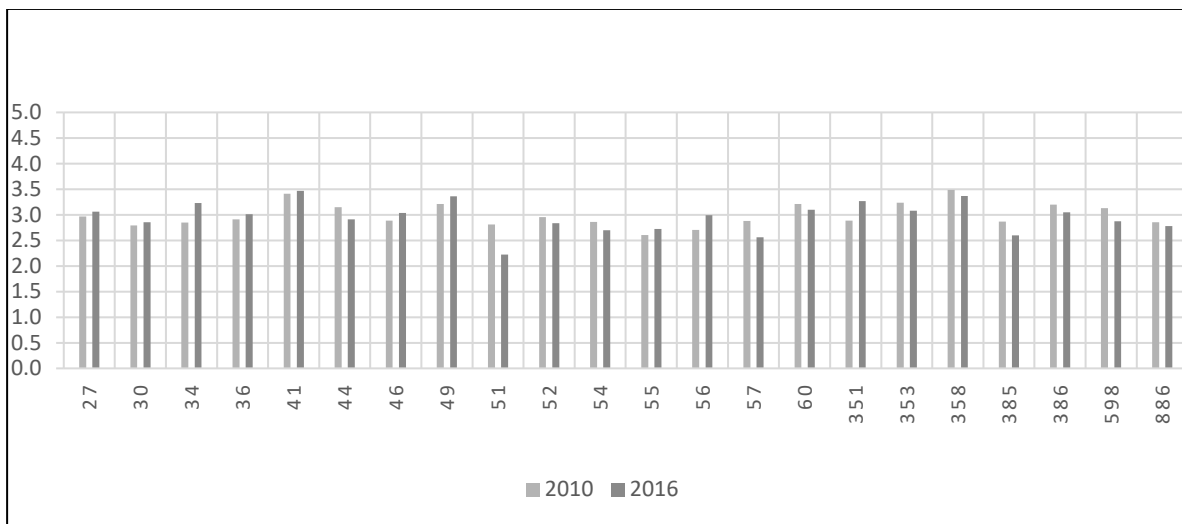

Figure 7. Commercial and Services Infrastructures between countries in 2010 and 2016

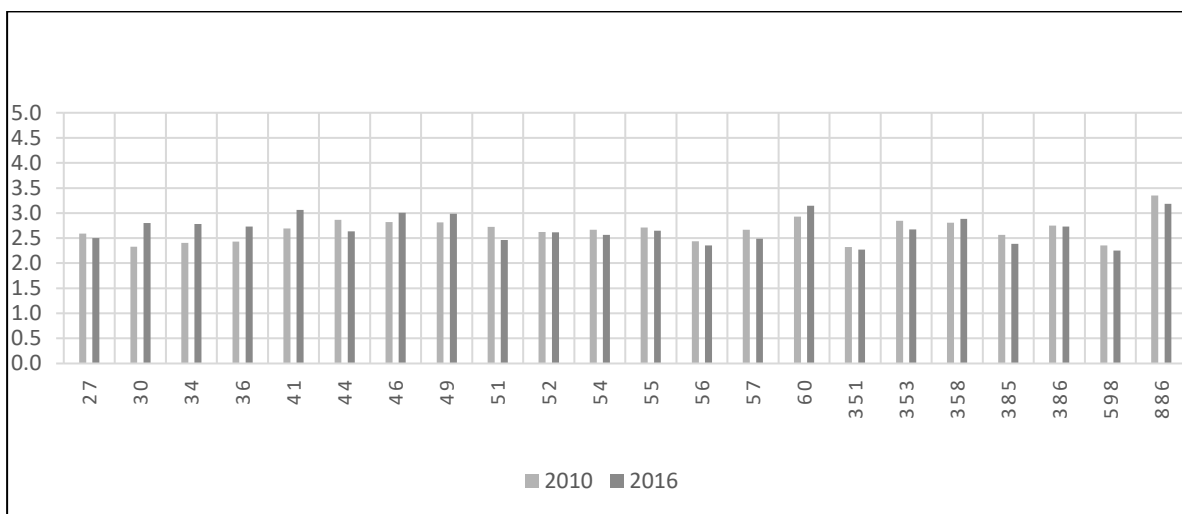

Figure 8. Market Openness between countries in 2010 and 2016

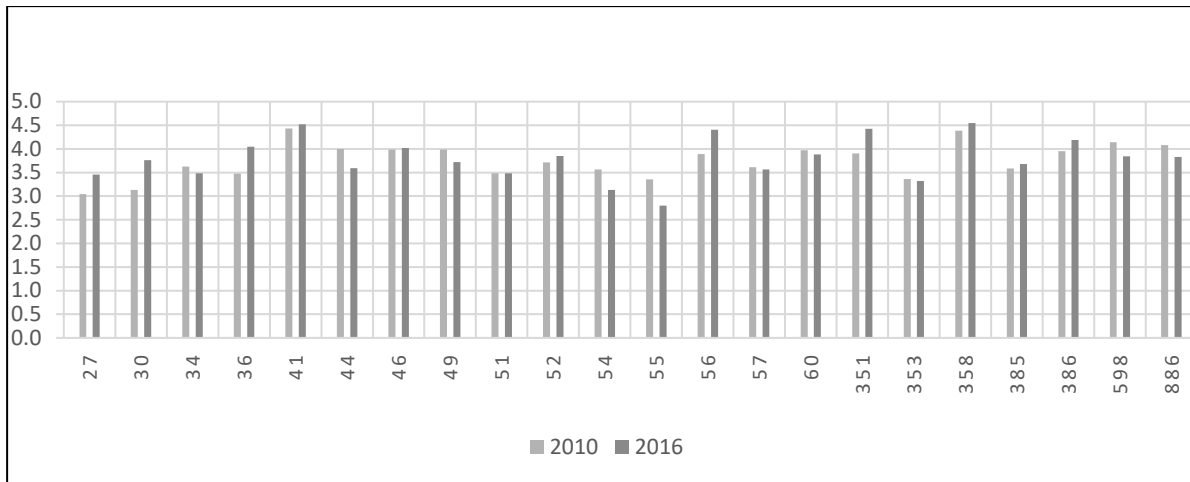

Figure 9. Physical Infrastructures between countries in 2010 and 2016

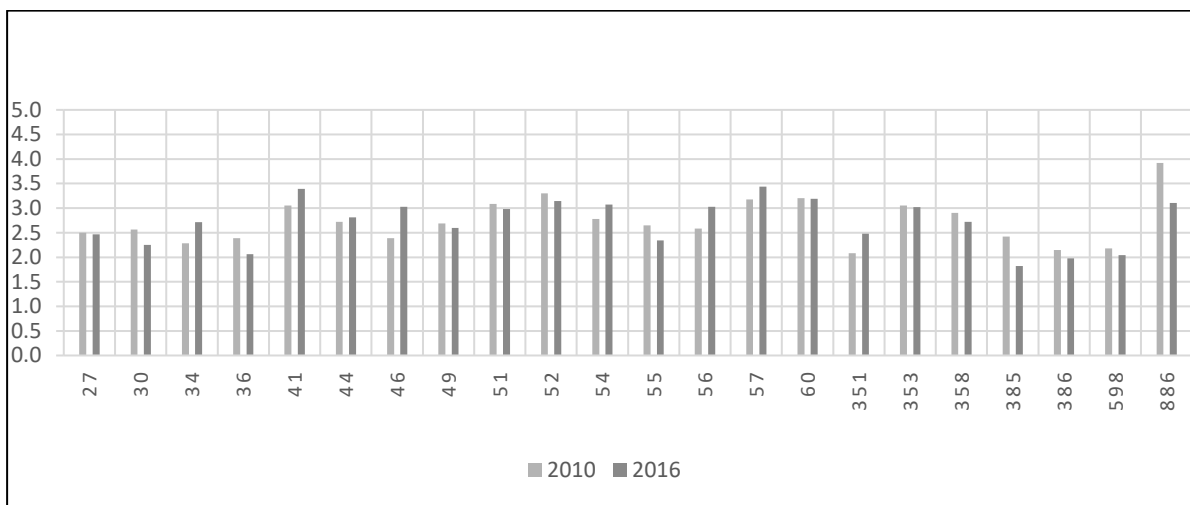

Figure 910. Cultural and Social Norms between countries in 2010 and 2016

Concerning EA, the data presented on Table 2, demonstrate that countries with EE with higher quality do not display better entrepreneurial activities rate when compared to those worst positioned as the case of Peru, Chile or Colombia. Those three countries reveal that beyond 20% of individuals choose to enterprise, but Peru stands with an impressive 36,6%. Other countries such as Mexico, Argentina, Brazil, or South Africa reach more than 10% of entrepreneurial activity, despite the role of institutions and policies being low.

Country (Code)	2010	2011	2012	2013	2014	2015	2016
South Africa (27)	0,11	0,16	0,13	0,15	0,11	0,13	0,12
Greece (30)	0,04	0,06	0,05	0,04	0,05	0,05	0,05
Spain (34)	0,02	0,05	0,04	0,04	0,04	0,04	0,04
Hungary (36)	0,05	0,10	0,10	0,09	0,11	0,09	0,09
Switzerland (41)	0,03	0,05	0,05	0,07	0,06	0,07	0,07
United King. (44)	0,03	0,07	0,07	0,05	0,08	0,06	0,07
Sweden (46)	0,02	0,04	0,05	0,05	0,05	0,05	0,04
Germany (49)	0,05	0,07	0,06	0,07	0,06	0,06	0,07
Peru (51)	0,36	0,37	0,33	0,33	0,42	0,37	0,38

Mexico (52)	0,18	0,12	0,14	0,20	0,18	0,24	0,13
Argentina (54)	0,10	0,19	0,18	0,18	0,15	0,17	0,14
Brazil (55)	0,12	0,11	0,12	0,15	0,09	0,15	0,13
Chile (56)	0,16	0,27	0,22	0,26	0,27	0,30	0,26
Colombia (57)	0,15	0,27	0,30	0,35	0,31	0,36	0,29
Malasya (60)	0,06	0,10	0,07	0,07	0,06	0,05	0,08
Portugal (351)	0,04	0,07	0,08	0,08	0,11	0,09	0,08
Ireland (353)	0,08	0,07	0,06	0,08	0,05	0,15	0,17
Finland (358)	0,02	0,04	0,05	0,04	0,05	0,07	0,07
Croatia (385)	0,06	0,13	0,15	0,15	0,15	0,12	0,15
Slovenia (386)	0,03	0,05	0,08	0,09	0,09	0,07	0,08
Uruguay (598)	0,10	0,14	0,13	0,13	0,15	0,15	0,17
Taiwan (886)	0,13	0,09	0,17	0,08	0,09	0,09	0,07

Table 2. *Entrepreneurial Activity (2010-2016) for 22 countries*

This suggest that EEQ is not directly related to EA, which means that is not a matter of resources but resourcefulness. Also, the results evidences that countries commonly posited as developed do not perform better in terms EA. Such results could open new avenues to explore differences among countries in terms of entrepreneurial culture and social context since EA tend to be more expressive in regions where role modelling is more profuse.

## 5. CONCLUSION

The present study followed the prior contributions about EE and aimed to tackle the shortage of empirical studies departing from two research questions: *how entrepreneurial ecosystem quality relates with entrepreneurial initiative* and *what EE conditions are prevalent in countries with higher EA*. The relevance of this study is fuelled by the need of discovering the asymmetries between EEQ and its relationship with EA, in order to help academics and policymakers designing more efficient EE and enlarge EA. The results of the study evidence the existence of dissimilarities between countries but, simultaneously, shed the light on possible crossed EEQ and EA patterns. Firstly, the study points that EE are not directly related to EA, as proved by several countries that exhibit frail EEQ but possess high levels of EA. After, the analysis based on EE individual dimensions, reveal that access to finance, education or government policies are less strong then expected when it comes to induce EA. More, EA seems to be a phenomenon that is nourished by the perception of stable and reliable EE, being those strong or weak, bringing constancy to a process that is frequently uncertain. Overall, this study empirically extends the discussion around EE and proposes the conceptualization of Entrepreneurial Ecosystems Quality as a new approach to the topic. At last, this work aims to place the foundations for new studies, grounded on multi-layer perspectives with taxonomic purposes.

## LITERATURE:

1. Acs, Z. J., Stam, E., Audretsch, D. B., & O'Connor, A. (2017). The lineages of the entrepreneurial ecosystem approach. *Small Business Economics*, 49(1). <https://doi.org/10.1007/s11187-017-9864-8>
2. Atilla Öner, M., & Kunday, Ö. (2016). A study on Schumpeterian and Kirznerian entrepreneurship in Turkey: 2006–2013. *Technological Forecasting and Social Change*, 102, 62–71. <https://doi.org/10.1016/j.techfore.2015.09.005>

3. Audretsch, D. B., Hülsbeck, M., & Lehmann, E. E. (2012). Regional competitiveness, university spillovers, and entrepreneurial activity. *Small Business Economics*, 39(3), 587–601. <https://doi.org/10.1007/s11187-011-9332-9>
4. Bosma, N., & Kelley, D. (2019). *Global Entrepreneurship Monitor: 2018/2019 Global Report*.
5. Breazeale, N., Fortunato, M. W., Iv, J. E. A., & Ronald, J. (2016). *Constructing a multi-dimensional measure of local entrepreneurial culture*. October 2015. <https://doi.org/10.1080/15575330.2015.1080743>
6. Brown, R., & Mason, C. (2017). Looking inside the spiky bits: a critical review and conceptualisation of entrepreneurial ecosystems. *Small Business Economics*, 49(1), 11–30. <https://doi.org/10.1007/s11187-017-9865-7>
7. Cavallo, A., Ghezzi, A., & Balocco, R. (2019). Entrepreneurial ecosystem research: present debates and future directions. *International Entrepreneurship and Management Journal*, 15(4), 1291–1321. <https://doi.org/10.1007/s11365-018-0526-3>
8. European Commission. (2013). *Entrepreneurship 2020 Action Plan*.
9. European Commission, & Commission, E. (2013). *Entrepreneurship 2020 Action Plan: Reigniting the entrepreneurial spirit in Europe: Vol. COM(2012)* (Issue 2012).
10. Fayolle, A., & Gailly, B. (2015). The Impact of Entrepreneurship Education on Entrepreneurial Attitudes and Intention: Hysteresis and Persistence. *Journal of Small Business Management*, 53(1), 75–93. <https://doi.org/10.1111/jsbm.12065>
11. Ghosh, P. K., Ghosh, S. K., & Chowdhury, S. (2018). Factors hindering women entrepreneurs' access to institutional finance- an empirical study. *Journal of Small Business & Entrepreneurship ISSN:*, 30(4), 279–291. <https://doi.org/10.1080/08276331.2017.1388952>
12. Levie, J., & Autio, E. (2007). Entrepreneurial framework conditions and national-level entrepreneurial activity: Seven-year panel study. *Third Global Entrepreneurship Research Conference*, 1–39. <http://citeseerx.ist.psu.edu/viewdoc/download?doi=10.1.1.462.6312&rep=rep1&type=pdf>  
[http://www.gemconsortium.org/assets/uploads/1326045129Entrepreneurial\\_Framework\\_Conditions.pdf](http://www.gemconsortium.org/assets/uploads/1326045129Entrepreneurial_Framework_Conditions.pdf)
13. Levie, J., & Autio, E. (2008). A theoretical grounding and test of the GEM model. *Small Business Economics*, 31(3), 235–263. <https://doi.org/10.1007/s11187-008-9136-8>
14. Mack, E., & Mayer, H. (2016). The evolutionary dynamics of entrepreneurial ecosystems. *Urban Studies*, 53(10), 2118–2133. <https://doi.org/10.1177/0042098015586547>
15. Malecki, E. J. (2018). Entrepreneurship and entrepreneurial ecosystems. *Geography Compass*, 12(3). <https://doi.org/10.1111/gec3.12359>
16. Reynolds, P., Bosma, N., Autio, E., Hunt, S., De Bono, N., Servais, I., Lopez-Garcia, P., & Chin, N. (2005). Global entrepreneurship monitor: Data collection design and implementation 1998-2003. *Small Business Economics*, 24(3), 205–231. <https://doi.org/10.1007/s11187-005-1980-1>
17. Roundy, P. T. (2019). Back from the brink: The revitalization of inactive entrepreneurial ecosystems. *Journal of Business Venturing Insights*, 12. <https://doi.org/10.1016/j.jbvi.2019.e00140>
18. Roundy, P. T., Bradshaw, M., & Brockman, B. K. (2018). The emergence of entrepreneurial ecosystems: A complex adaptive systems approach. *Journal of Business Research*, 86, 1–10. <https://doi.org/10.1016/j.jbusres.2018.01.032>
19. Spigel, B. (2017). The Relational Organization of Entrepreneurial Ecosystems. *Entrepreneurship Theory and Practice*, 44(0), 49–72. <https://doi.org/10.1111/etap.12167>

20. Stam, E. (2015). Entrepreneurial Ecosystems and Regional Policy: A Sympathetic Critique. *European Planning Studies*, 23(9), 1759–1769.  
<https://doi.org/10.1080/09654313.2015.1061484>
21. Xu, Z., & Dobson, S. (2019). Challenges of building entrepreneurial ecosystems in peripheral places. *Journal of Entrepreneurship and Public Policy*, 8(3), 408–430.  
<https://doi.org/10.1108/JEPP-03-2019-0023>

## **EDUCATION AS ONE OF THE PHENOMENA OF CONTINUOUS DEVELOPMENT**

**Rashad Huseynov**

*Associate prof., Scientific-Research Institute of Economic Studies under Azerbaijan State University of Economics (UNEC), Azerbaijan  
rashadhuseynov2013@gmail.com*

**Farhad Mikayilov**

*Associate prof., Senior researcher, Scientific-Research Institute of Economic Studies under Azerbaijan State University of Economics (UNEC), Azerbaijan  
farhad.mikayilov@unec.edu.az*

**Shafiga Mammadova**

*Associate prof., Sumgait State University, Azerbaijan  
shafiga\_mammadova@mail.ru*

**Elman Ibishov**

*Associate prof., Senior researcher, Scientific-Research Institute of Economic Studies under Azerbaijan State University of Economics (UNEC), Azerbaijan  
elman.ibishli@gmail.com*

**Rafail Rzayev**

*Scientific-Research Institute of Economic Studies under Azerbaijan State University of Economics (UNEC), Azerbaijan  
rrzabeyli@rambler.ru*

### **ABSTRACT**

*In the civilized world, education has become one of the most important tools for the modernization of society, as well as for the development of the economy and the state. At the same time, it is increasingly important to acquire new knowledge and apply it in practice. Therefore, ensuring the mutual integration of science and education and extensive use of the opportunities of this process to achieve sustainable development is one of the most pressing problems of modern development. The fourth of the 17 goals of sustainable development is related to education, providing inclusive and equal quality education for all and supporting lifelong learning opportunities. The main purpose of education for sustainable development is to bring up educated people with comprehensive knowledge in society, socially active, able to understand the processes and events in public life, modern worldview, moral, cultural and ethical values, socially responsible, behavioral norms. This research examines the role of education in ensuring sustainable development, the relationship between education and environmental, economic development and labor market development. Education has the ability to solve and eliminate environmental problems, to ensure the formation of an environmentally responsible society to prevent them. Education also increases people's ability to withstand the risks associated with environmental change. Education enables people to learn, increase their knowledge and improve their economic situation, lift them out of poverty, and achieve inclusive development by providing them with new knowledge, skills and habits. The solution of these issues is increasing the relevance and importance of lifelong learning in society. Higher and modern levels of education also expand people's opportunities to find work by making them more competitive in the labor market.*

*In general, education provides a solid foundation for improving the living standards of members of society and ensuring a healthy, value-based lifestyle, gender equality in society, and the understanding and promotion of rights and freedoms.*

**Keywords:** Education, sustainable development, level of education, standard of living, environmental development, lifelong learning

## 1. INTRODUCTION

The role of science and education is constantly growing in our modern world, in its development and future progress. Education has become one of the most important tools for changing the mindset and behavior of members of society, the modernization of society as a whole, as well as the development of the economy and the state. The importance of this effect is increasingly outweighing the importance of acquiring new knowledge and applying it in practice. As a result, education and science today play a key role in bringing about change to achieve the goals of sustainable development.

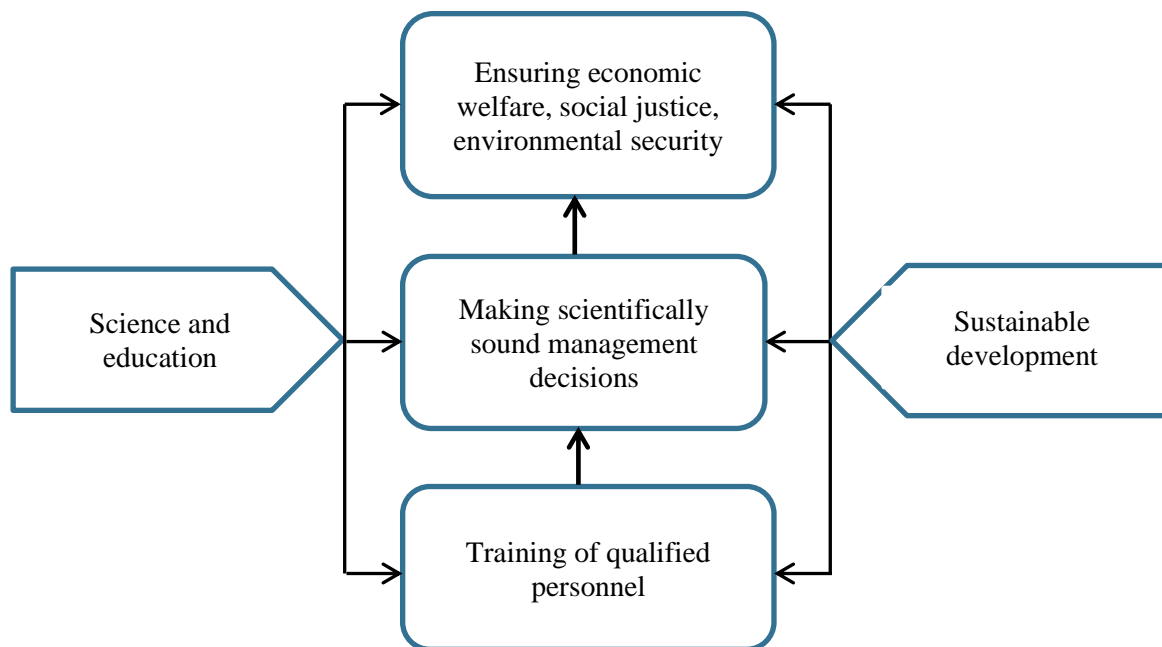

**Figure 1. The relationship between science, education and sustainable development.**

Source [1; 2]: Compiled by the author.

One of the most important points in this process is the reconstruction and modernization of the educational process as a whole in terms of sustainable development goals. Thus, sustainable development is the main goal and direction of development of the world and humanity in the 21st century. Education for sustainable development are the processes and their consequences related to the prediction and formation of human qualities and characteristics (knowledge, skills and habits, attitudes, skills, personal qualities, activity style, etc.) that improve the quality of life of members of society within the natural capacity of the surrounding ecosystem. [2]

The main purpose of education for sustainable development is to bring up educated people with



comprehensive knowledge in society, socially active, able to understand the processes and events in public life, modern worldview, moral, cultural and ethical values, socially responsible, behavioral norms. To achieve this goal, education for sustainable development helps to address a number of issues:

- ✓ to assist members of society in acquiring knowledge, skills, abilities and experience, developing their creative abilities, and providing opportunities for self-development;
- ✓ development and dissemination of knowledge about the environment and its condition;
- ✓ development and application of recommendations, criteria and standards with a comprehensive solution of economic, social and environmental issues and environmental protection;
- ✓ identification of opportunities for economic development in the field of environmental protection.
- ✓ to increase the importance of activities within the framework of ecological traditions and ecological goals and to educate and enlighten the society in the spirit of careful attitude and behavior towards natural and cultural heritage;
- ✓ to assist in ensuring the personal development, self-development and self-realization opportunities of students;
- ✓ formation of an active civil position in the members of the society;

It should be noted that the solution of these issues, along with the modernization and development of the education system, also creates the need for joint activities of various structures in society, including government agencies, the private sector, civil society institutions and the population. At the same time, one of the main issues is related to the development of the education system. This issue is fixed in the "Diary - 21" document. The following provisions are reflected there:

1. Reorganization of education in the direction of sustainable development;
2. Increasing the level of practical training of all segments of society in the field of sustainable management of territories, resources, economy, socio-cultural life.
3. Improving the basic education system.
4. To increase the level of awareness of the members of the society on the issues related to the state of the environment and to ensure their participation in the protection and improvement of the environment and to build confidence in it.
5. To create conditions for the members of the society to understand the social significance of the perspectives and principles of sustainable development.

In terms of sustainable development, the development of education allows graduating high school, college and university students, as well as working people, to acquire knowledge, skills and habits to maximally improve the living standards and quality of society, the development of society and the economy, and the creation of harmony between nature and society. Education is an integral part of human society and human development. It transmits to the future, including (reflecting) the main features and means of sustainable and sustainable development of society and the world, ensuring their development. It is this aspect that makes the development of science and education necessary for sustainable development. In the context of sustainable development, education as a leading factor in this process, interacts with all three process components, in the social, economic and environmental aspects, and ensures their unity. Education provides an understanding of the scale and nature of problems in the field of sustainable development, and opportunities for a critical, non-standard and supportive approach to solving these problems. helps to find more effective solutions to problems of global importance, teaches members of society the ability and skills to act for a sustainable and sustainable future. [4] Education is the basis for the formation and development of a society

with sustainable and sustainable development qualities. The formation and organization of education, which will serve the goals of sustainable development, is a world-class educational process, which necessitates revolutionary changes in education and science, as well as the integration of education and science. The fourth of the 17 Sustainable Development Goals is education-related, providing inclusive and equally quality education for all and supporting lifelong learning opportunities. The targets and indicators for this purpose are shown in the table below.

**Objective 1. To provide inclusive and equal quality education for all and to support lifelong learning opportunities**

Targets	Indicators
4.1. To ensure that by 2030, all students complete free, quality, equal primary and secondary education, leading to appropriate and effective learning outcomes.	4.1.1. a) students in 2nd and 3rd grades; b) primary school graduates; c) the share of children and young people who have achieved at least a minimum level of reading and 2) mathematical skills among high school graduates, considering the gender
4.2. To ensure that by 2030 all students have an access to a quality early childhood development, care and pre-school education in order to be ready for primary education.	4.2.1 The specific weight of children under the age of five, who develop without deviations in terms of health, education and psycho-sociological well-being; 4.2.2 Level of participation in organized forms of training (1 year before the officially established primary education age), considering the gender
4.3. By 2030 to ensure equal access to quality affordable, technical, vocational and higher education, including university education, for all women and men.	4.3.1 Vocational training of adults and youth in the last 12 months, level of participation in formal and non-formal education, considering the gender
4.4. By 2030, significantly increase the number of young people and adults who are successfully employed, create decent job opportunities, develop entrepreneurial skills, including technical and vocational skills.	4.4.1 The share of young people and adults with the ability to use information and communication technologies (ICT) in the distribution of types of skills
4.5. By 2030, eliminate gender inequalities in education and ensure equal access to education and vocational training at all levels for vulnerable groups, including people with disabilities, indigenous people and low-income children.	4.5.1 Equality index on all indicators related to education and which can be disaggregated in this list (women and men, urban and rural residents, lower and upper classes, and other population groups, such as people with disabilities, indigenous peoples and people affected by the conflict).
4.6. By 2030, ensure that a large proportion of all young people and adults, both men and women, are literate both mathematically and in general terms.	4.6.1 a) literacy and b) the share of the population that has reached at least a certain functional level of mathematical literacy in that age group, considering gender

<p>4.7. By 2030, all learners, among other things, are committed to sustainable development and sustainable lifestyles, human rights, gender equality, the promotion of a culture of peace and non-violence, world peace and cultural diversity. The knowledge and skills required to promote sustainable development through education for the sustainable development of culture.</p>	<p>4.7.1 a) status in national education policy, b) curricula, c) teacher training programs, and d) student attestation system i) education in the spirit of world citizenship and ii) promotion of sustainable development including gender equality and human rights at all levels .</p>
<p>4.a. Establish and renovate educational institutions that are sensitive to childrens' disability and gender issues and provide a safe, non-violent, comprehensive and effective learning environment for all.</p>	<p>4.a.1 a) electricity usage; b) access to the Internet for educational purposes; c) access to computers for educational purposes; d) using main sources of drinking water; d) separate sanitary facilities for boys and girls; e) specific status of schools provided with basic hand washing facilities (in accordance with the definitions of water supply, sanitation and hygiene initiatives for all)</p>
<p>4.b. By 2020, higher education, including vocational training and information and communication technologies in developing countries and the least developed countries, developing countries located on small islands and African countries, significant increase the number of scholarships for technical engineering and scientific programs globally.</p>	<p>4.b.1 The amount of official assistance with the payment of development scholarships, their distribution of areas and types of education</p>
<p>4.c. By 2030, among other things, significantly increase the number of qualified teachers through international cooperation in teacher training in developing countries, especially in the least developed countries and developing countries located on small islands.</p>	<p>4.c.1 a) in pre-school educational institutions; b) in primary schools; c) the share of teachers who have completed the minimum vocational training (e.g. pedagogical) required by the relevant level in the country before or during employment in general secondary school and d) in full secondary school</p>

Source: [7; 8]

Education is closely linked to all three areas of sustainable development, as well as to each of the 17 other 16 goals. The education factor plays a significant role in raising the living standards of each member of society, in general, in ensuring the development of society, and education has great potential in this direction. In order to identify these opportunities, it is important to study the impact of education on other goals of sustainable development. This can be seen in the figure below.

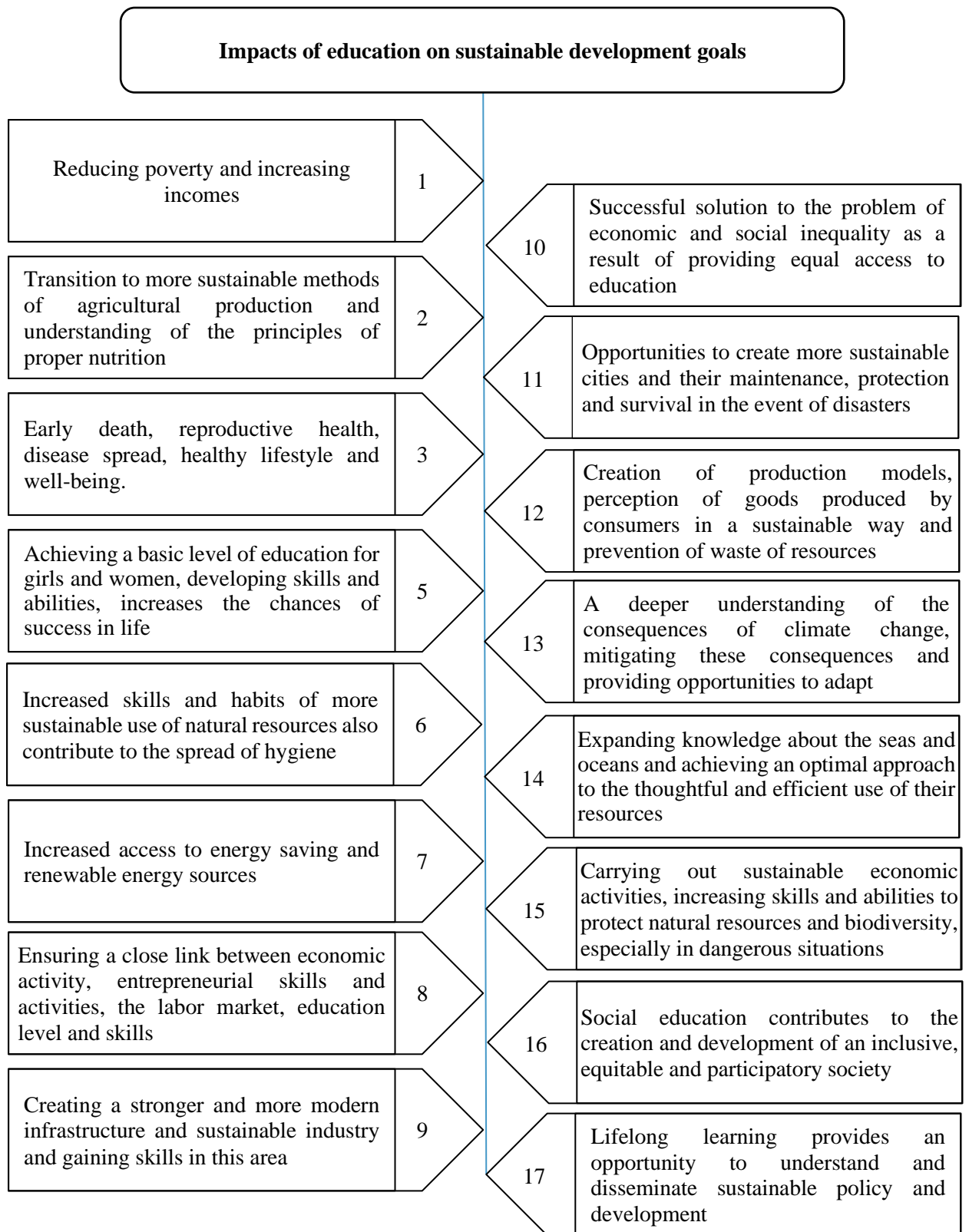

**Picture 1.** The link between education and sustainable development goals

**Source [6]:** Compiled by the author.

## **2. EDUCATION AND ECOLOGY: THE ROLE AND IMPORTANCE OF ENVIRONMENTAL EDUCATION**

Human activities, both individually and collectively, demographic growth, modern lifestyles and human behavior have a significant impact on the environment and the living things on our planet. This impact is directed towards the deterioration of the environment, climate change and biodiversity, and depletion. Even in countries with high living standards, the impact on the environment has more than doubled in the last 20 years. It can be said that human behavior has already caused many environmental problems, and is a key factor in solving and eliminating these problems and preventing them. Of course, the most powerful tool a person can use in this matter, even the most powerful weapon with a wide range of possibilities, is education. It is education, as an important factor that forms the basis of sustainable development, that has the potential to ensure the formation of an environmentally responsible society that can prevent these processes and guide them in the right direction. The development of means and methods of avoiding educational activities plays an important role in the development of practical skills in this area. Environmental education promotes the formation and dissemination of environmental values and rational environmental norms and lifestyles in society, resulting in a reduction in emissions, increasing energy efficiency, and mastering the skills of efficient use of resources. Increased tendency of people to environmental activities and policies and the formation of its support and positive attitude by society. Education increases people's ability to resist the risks associated with environmental change. Increasing access to education for community members can be more rewarding than increasing investment in infrastructure. Experience and forecasts show that the low level of education and knowledge of the people results in an increase in deaths during natural disasters. If this continues, it could result in a 20% increase in the number of deaths from natural disasters in the future every 10 years. Therefore, low or limited access to education makes people in poor countries more exposed to environmental risks and unable to be prepared for them, unable to respond to warnings in a timely manner, and unable to take action.

## **3. EDUCATION AND ECONOMIC DEVELOPMENT**

Changes in society, in nature, and in the world in general, require people to acquire new knowledge, skills, and habits. This creates a need for people to learn and increase their education throughout all their activities, which, in turn, increases the relevance and importance of lifelong learning. The high level of education, the acquisition of modern knowledge and skills create ample opportunities for people to expand their income opportunities, increase their incomes, improve their living standards and quality of life. Well-educated, highly qualified professionals have more flexibility and modern knowledge and experience to implement economic change. Lifelong learning and training are especially important to ensure the sustainability and sustainability of development. This is important for the sustainability of production and consumption, the development of knowledge and skills required for the creation of a "green" economy, industry, and requires higher education and research to focus on the creation and application of environmental innovations. In terms of sustainable development, this means not only that the economy is sustainable, but also that it is inclusive and fair. The main way to achieve these goals is to provide quality education and new scientific research. Ensuring inclusive economic growth is based on the availability of highly qualified personnel and specialists. This is important both in terms of improving people's living standards and their quality, and in terms of the greening of industry and the economy as a whole. The greening of the existing industry requires the organization of training and education of low and middle level workers without leaving the production. therefore, enterprises must first determine what professional knowledge and skills they need in the face of rapid economic change. Ensuring sustainable development and "green" economic growth also requires significant investment in

research and development. The training of personnel with modern knowledge and skills for various sectors of the economy requires the modernization of the education system itself, the development of educational programs in accordance with the specific tasks and objectives of sustainable development and the implementation of interdisciplinary research programs. According to international organizations, for the development of the low-carbon industry, governments and states should increase investment in scientific research more than 5 times for the training of specialists in the field of energy. Agriculture currently accounts for more than a third of greenhouse gas emissions. Therefore, the greening of this area, the development of environmentally friendly agricultural production is an inevitable reality. There is a special need to train qualified personnel in this area as well. Increasing people's literacy in agriculture and spreading new knowledge can help increase agricultural production by 12%. Scientific research helps to create and apply innovations in this area.

#### **4. EDUCATION AND LABOR MARKET**

To ensure the growing role of education in ensuring sustainable economic growth, it is essential to adapt it to the requirements of the labor market. The application of modern technologies increases the need for highly qualified personnel, as well as reduces the demand for mid-level workers. Therefore, it is important to develop education and training, taking into account the requirements of the labor market. It is estimated that by 2020, the global shortage of highly qualified specialists will be 40 million, and the shortage of low-skilled workers will be 95 million [5]. In this regard, it is projected that the competencies and skills formed and developed within general education, including critical thinking, problem-solving skills, teamwork and project implementation skills, along with continuous literacy skills (continuing education skills), communication and information presentation skills, will be among the most sought after qualities in the labor market. One of the main tasks of today's education system is to find effective ways and methods of teaching these habits and skills. In countries with a high level of economic development, the unemployment rate is low among the able-bodied population, especially among people aged 25-64. The employment rate is 55% among people with incomplete secondary education, 73% among people with secondary and secondary special education, and 83% among people with higher education. Among the population aged 15-29, these ratios are 49%, 73% and 83%, respectively. In less developed and poorer countries, these ratios may be different and vice versa. This is due to the low demand for highly qualified specialists in the economy in those countries, or the inability of the education system to provide the knowledge and skills required by the economy. Providing access to education services expands opportunities for socially vulnerable people to find decent work. In order to increase students' interest in higher education, investment in education should be combined with economic policies aimed at increasing the demand for highly skilled labor. Therefore, the education system should allow such a large number of workers who have lost their jobs to acquire new professions, improve their skills and change.

#### **5. EDUCATION AND SOCIAL DEVELOPMENT**

Education is very important for the social development of society and has great potential. It plays a key role in raising the living standards of members of society and ensuring a healthy as well as value-based lifestyle. Education plays an important role in ensuring gender equality in society, understanding and ensuring rights and freedoms, and forms a solid basis for this. Education increases the income of the poor by increasing their opportunities to find work and employment. This creates favorable conditions for the prevention of stratification in society, its elimination, ensuring a fair distribution of resources among members of society, the elimination of inequality. The elimination of inequality in society is possible only if the state pursues a policy of equal access to education, vocational training and skills development programs, as

well as a policy of fair distribution of resources and benefits among society, ie implement a social policy based on the principles of improved redistribution. Education has a great impact on social development. Thus, education is closely involved in this process, simultaneously having a direct impact on improving the results of social development in several areas. Education provides opportunities for social development in the following areas:

1. Acts as a key factor in improving people's living standards and quality.
2. By providing the necessary knowledge, skills and abilities to the members of the society, it creates a wide range of opportunities to ensure their healthy lifestyle.
3. Raising the status of women in society expands their opportunities for active participation in the development of society.
4. Ensuring gender equality in society expands the rights and opportunities of socially vulnerable groups, especially women and girls.

Education closely helps people and their families to improve their health, prevent diseases, use medical services and tools, create a healthy diet, create a healthy environment, as well as healthy living conditions, and provide opportunities for the spread of healthy habits. The knowledge gained through education helps people in the areas of health protection, healthy eating, disease prevention and treatment, as well as access to information about diseases, its proper use, and disease prevention. At the same time, educated people kind of share the responsibility for their health with their doctor, and with the ability to participate in the treatment process, both improve the results of treatment and reduce the cost of treatment. The results of many studies show that higher education encourages people, especially women, to use environmentally friendly fuels, as well as healthier and more environmentally friendly sources of electricity and appliances, and environmentally friendly kitchen stoves. For example, an increase in the study period by one year increases the probability of using environmentally friendly fuels by 0.66%.

Research in poor countries has shown that school meals, especially in primary and secondary schools, and the organization of various other companies stimulate the flow of children to school. Such measures are particularly effective in areas where the poor are densely populated and children are less involved in school. Regular research in sub-Saharan Africa, Southeast Asia, South Asia, Latin America and the Caribbean has shown that school nutrition is one of the main reasons for the steady improvement in overall health and the quality of nutrition. The implementation of some programs has even improved the growth rate of students. Education provides opportunities for society to address health issues. First of all, the fact that mothers are educated and have a high level of education has a strong positive impact on the development of an entire generation, creating favorable conditions for large-scale changes in society as a whole. Educated parents, especially educated mothers, can better provide their children with a healthy diet and lifestyle. Educated women have access to better, more qualified medical services, which enables them to give birth to healthy children and raise them healthy. These processes ultimately lead to a reduction in infant and child mortality, as well as maternal mortality in the country, the growth of a healthy population, and the health of the human race. This means that the high level of education and literacy of mothers in society has a significant positive impact on the health and education of children in the family. Just as education provides a solid foundation for social development and ensures its inclusiveness, the occurrence of social development in turn determines the development of education and its growing role in society. It should be noted that if social development is not inclusive, it can not make the necessary contribution to the development of education.

## 6. CONCLUSION

In general, education is closely linked to all three components of sustainable development - economic, social and environmental - at the level of cause-and-effect relationships, and is directly involved in ensuring all three. Education is a very powerful tool for people to lead a healthy life and improve their lives. It plays the role of a fundamental basis for these processes, forming the basis for serious and radical changes in the life of society, the implementation of reforms. First of all, because education, both as a system and as a process, is closely and directly related to all spheres of society, all spheres of human life, all aspects of the social sphere and social development. Therefore, the preparation of development strategies for both education strategy and other social spheres is generally considered a key component of human development processes and requires a comprehensive approach.

## LITERATURE:

1. Азизов А.А., Акиншина Н.Г. Образование в интересах устойчивого развития. Учебно-методическое пособие. Ташкент, 2009, 142 с. с.8
2. Грачев В.А., Ильин И.В., Урсул А.Д., Урсул Т.А., Андреев А.И. Образование для устойчивого развития в России: проблемы и перспективы (Экспертно-аналитический доклад). – М.: Издательство Московского университета, 2017, 207 с.
3. Ермаков Д.С. Содержание образования для устойчивого развития // Вестник РУДН, серия Психология и педагогика, 2013, № 3, с.91-96
4. Шимова, О.С. Глобальная программа действий по образованию для устойчивого развития в контексте "зеленой" экономики // Научные труды Белорусского государственного экономического университета. Минск : БГЭУ, 2017. Вып. 10, с. 471-476.
5. Образование в интересах людей и планеты: Построение устойчивого будущего для всех. Резюме. Всемирный доклад по мониторингу образования за 2016 год. 64 с. с.15
6. Образование в интересах людей и планеты: Построение устойчивого будущего для всех. Всемирный доклад по мониторингу образования за 2016 год. 587 с. С.85
7. <http://unazerbaijan.org/az/sdgs/dm4-keyfiyy%c9%99tli-t%c9%99hsil/>
8. <http://sdg.azstat.org:8484/az/national-priority/4/keyfiyyetli-tehsil#>



## TECHNOLOGICAL RISE HEAVILY IMPACTS E-COMMERCE INDUSTRY

**Daniel Panduric**

*University North, Croatia  
dapanduric@unin.hr*

**Igor Klopotan**

*Polytechnic of Međimurje in Čakovec, Croatia  
igor.klopotan@mev.hr*

**Tesa Klopotan**

*University of Zagreb, Faculty of Political Science, Croatia,  
tklopotan15@gmail.com*

### ABSTRACT

*The way people and businesses mutually trade goods and services is a never-ending cycle of change. The change is due to advances in various fields of science, but due to the invention of computers and microprocessors that change is more evident in the last fifty years. The main force driving that change are the consumers. A few companies adopted the use of new technologies, especially bigger companies with bigger market shares. So it is usually down to the consumers to “vote” with their money and virtually “force” companies to adapt or to go bust. And with widespread usage of the internet and other technological advances (like social networks and smartphones) that change is even more accelerated. So the retail industry is facing an unforeseeable future.*

**Keywords:** *retail, digitalization, trade, digital commerce, social networks, consumers*

### 1. INTRODUCTION

The most common and well-known form of trade is retail – a classic form in which an individual (a buyer/consumer) goes to the store -the sales area of a company to buy certain products (and nowadays services). But how important is this branch of entrepreneurship to the modern economy?

According to the data of the American Bureau of Labor Statistics for the year 2019, the US retail industry generated an added value of \$ 1.132 trillion, which is 5.5% of US gross domestic product, while the retail sector employs as many as 4.8 million people (which is about ~ 3% of the US workforce). Additionally, the importance of retail is visible in data from the American organization credit donkey, which states that a U.S. citizen with median income spends as much as 97% of that income on trade (in total - through all sectors - from groceries to housing, transportation, etc.) - and sometimes even more than people earn. According to all that data, it can be seen that trade is an important pillar of the economy, companies generate a large amount of income (and profit) through trade and employ a significant number of people.

However, despite the fact that the trade sector is important for every economy, it does not mean that there are no dangers for it that could significantly jeopardize the way and form of trade. Technological progress is one of the processes that constantly pushes all sectors of the economy forward. Following the innovations that take place on a daily basis nowadays, the appearance and shape of most sectors of the economy are changing - including trade. This is a challenge for retailers - to keep up with the times or to be forgotten forever.

## 2. TECHNOLOGICAL PROGRESS

Technological progress is one of the unstoppable processes in human nature. It has been taking place continuously from the very beginnings of human history to the present day, without interruption. The driving force of progress is the human desire to improve and facilitate one's own life. There are many examples that could be given here, but some of the biggest and most important ones through history certainly are – the wheel, the first industrial revolution (i.e. the steam engine), the second industrial revolution (i.e. electricity), the third industrial revolution (*the digital revolution* – the invention of the personal computer) and of course the one we are living through – the fourth industrial revolution. All revolutions are specific due to the significant impact on society, politics and economy (Makridakis, 2017). Of course, all participants of the public square benefit from this. People who start using new technologies for their own needs, politics - that is, states and their governments, which through the regulatory framework can limit the use (creating new revenues through taxes) and companies - for use in a day-to-day business. They use new technologies to accelerate and / or facilitate their business processes (this can best be seen on the example of a steam engine - used in the economy to speed up the business process (the machine is faster than man) and reduce costs - despite a larger initial investment in the machine, in the long run it is cheaper than paying an employee. Such changes, of course, also have a significant impact on the competitive market. Companies, especially newer and smaller ones, are more inclined to introducing new technologies into their day-to-day procedures - which gives them a certain competitive advantage over time as people tend to use businesses that simplify their interactions (Baines & Edwards, 2018). The result is that companies that resist the introduction of changes in business, no matter how big, generally lose pace with companies that introduce these changes. For bigger companies, this can often lead to the loss of a significant portion of their market share and can often go completely bust. This affects all companies, even market leaders, and there are many examples of how big companies go bust this way (Poufelt et al, 2017). That examples are companies like Blockbuster (the American company for renting movies on VHS tapes), Atari (once the market leader in the field of video game consoles), Commodore (personal computers) and others. But perhaps the most famous example is Nokia, a Finnish company that 20 years ago was the largest and most famous manufacturer of mobile phones, only to go completely bust in a span of 10 years.

Company	2001 Shipments	2001 Market Share (%)	2000 Shipments	2000 Market Share (%)	Growth (%)
Nokia	139,672	35.0	126,369	30.6	10.5
Motorola	59,092	14.8	60,094	14.6	-1.7
Siemens	29,753	7.4	26,989	6.5	10.2
Samsung	28,234	7.1	20,639	5.0	36.8
Ericsson	26,956	6.7	41,467	10.0	-35.0
Others	115,877	29.0	137,173	33.2	-15.5
Total	399,583	100.0	412,731	100.0	-3.2

Table 4 Nokia as the leading phone manufacturer in 2001 - by Gartner Dataquest 2002 - <https://tech-insider.org/mobile/research/2002/0311-a.html>

## 3. THE MODERN BUYER/CONSUMER

In order to see what changes have been taken in the field of retail in the last twenty years and how technological advances have affected it, the most important thing is to have a detailed analysis of the consumer. Companies will spend significant resources to conduct market

research and gain insight into their current and potential consumers, determine their needs and adjust their business strategies accordingly (Wang & Kim, 2017). Renowned American author and entrepreneur Kevin Stirtz argues that every retailer needs to know what their customer wants, what the retailer can best offer, and base their offer in some middle ground between the two (Mushtaq & Mellouk, 2017). The company WeAreSocial, partnering with Hootsuite, conducts a yearly analysis to determine the habits and preferences of people as it pertains to the Internet, social media networks, mobile phones, buying and paying online etc. They revealed that the average internet user now spends 6 hours and 43 minutes online each day (Onden & Kiygi-Calli, 2018). That is 3 minutes less than this time last year, but still equates to more than 100 days of connected time per internet user, per year. If we allow roughly 8 hours a day for sleep, that means we currently spend more than 40% of our awake life using the Internet. However, just over 40% of the world's total population – roughly 3.2 billion people – remains unconnected to the internet. Of that number, more than 1 billion people live in Southern Asia and another 870 million people are located in Africa. Except geographical location, age and gender have a vital role in connectivity to the Internet (Maraz et al, 2016). Further on, data shows that women in India and Southern Asian are up to three times less likely to use the internet than men, or to be even aware of the existence of it. But the more important is the way that people are using the internet. GlobalWebIndex detects that more than half of all the time we spend online is on our mobile phones, with the company's data putting mobile's share of internet time at 50.1 percent (Graff et al, 2020). All of this data point to the fact that most people still use a variety of different devices to go online. As a result, a balanced device strategy is still essential. Moreover, people use different devices at different times and for different needs, so marketers must go beyond technical considerations to understand the various cases of use and contexts for each device when building their plans (Vardarlier, 2020). Data shared by App Annie reveals that in using mobile phones, we spend 10 out of 11 minutes using mobile apps, and only 9% of our daily use of mobile phones is for web browsing.

However, when we consider the extent of app offerings available to today's mobile users, this is perhaps unsurprising. Data revealed by Global Web Index show that we are using apps in almost every aspect of our lives, whether it is for staying in touch with family and friends, relaxing on the couch, managing our finances, getting fit, or even finding love. Roughly half of the 3.7 hours that people spend using mobile phones per day, are spent using social and communications apps, meaning that these platforms account for the same share of our mobile time as all of our other mobile activities put together (Thang & Ng, 2020). Across mobile devices and computers, Global Web Index reports that we now spend an average of 2 hours and 24 minutes per day using social media, which is up by 2 minutes per day since this time last year. Once again, the story varies from country to country. Filipinos are still the world's most 'social' people, where the average internet user aged 16 to 64 spends almost 4 hours per day on social platforms. Japan shows us a different picture, where the internet users spend an average of only 45 minutes per day using social media (Yeh et al, 2020). Despite various challenges over the past few years, Facebook is still on the top when it comes to the social media. Trends in the number of users that are reported in the company's earning announcements suggest that the platform should have already passed the historic 2.5 billion monthly active users (MAU) mark as the number of users continued to grow steadily across the most countries during 2019 (Pham & Tran, 2020). However, for various reasons, marketers cannot reach all of these users using Facebook advertising, and the platform's own self-service advertising tools indicate that the total addressable Facebook audience now stands at 1.95 billion, or roughly 80 percent of total MAUs. Critically, marketers can now use Facebook to reach one-third of all the world's adults aged 18 and above, and more than half of all the world's adults aged 18 to 34. When it

comes to website popularity, especially e-commerce websites, the latest rankings of the world's top websites illustrate the dramatic rise of Asia's ecommerce platforms.

In its latest list, Alexa [note: not the voice assistant] places China's Tmall in the third place in the global website rankings – that's ahead of both Facebook and Baidu, and 10 places higher than its top Western competitor, Amazon. Across the full top 20 sites, Alexa includes 5 Chinese ecommerce sites, 4 of which belong to Alibaba (Zhang, 2020). Roughly three-quarters of the world's internet users aged 16 to 64 buy something online each month, with Global Web Index finding that e-commerce adoption rates are highest amongst internet users in Indonesia, Thailand, and Poland (Balcerowska et al, 2020). The distribution of adoption across geographies suggests that economic development is not the primary determinant of e-commerce use, and that other factors are more important, such as sites that cater to the language needs and cultural preferences of local shoppers. Worldwide, e-commerce consumers are more likely to purchase through a mobile device than through a laptop, although the data reveal that most people use both devices for their online shopping, depending on the type of product they are buying and the context of their shopping activities. Meanwhile, the latest data revealed by Statista shows that e-commerce spending worldwide grew significantly during 2019, although – as one might expect – growth rates varied by category. Travel, the largest category in online consumer spending, experienced the slowest year-on-year growth amongst the categories that Statista tracks, with global annual revenues up by roughly 8 percent to reach US\$1.19 trillion (Puaschunder, 2019). At a global level, the average e-commerce shopper now spends almost US\$500 on online purchases of consumer goods each year, although Statista reports that this varies significantly from country to country, from an average of US\$1,441 per person in South Korea, to just US\$20 per person in the Philippines (Rishi et al, 2016). “Omnichannel” has become a buzzword in the retail industry, and rightly so: all the evidence indicates that when it comes to shopping, the world's shoppers are making less and less distinction between ‘online’ and ‘offline’. Blended behaviours such as ‘click and collect’ are on the rise, and showrooming – where consumers visit physical world stores before buying products online – is also an increasingly common practice.

#### **4. SOCIAL MEDIA AS A SALES CHANNEL**

While people usually associate e-commerce with websites and company web shops, with the emergence of social media in the last decade (Facebook started in 2004 but picked up most popularity around 2008) advertisers need to start thinking about Social Media as being less like a media placement for advertisements, and more like a tool for discovery. Savvy brands will need to start thinking about when and how users will come across their content; how best to optimize for discovery. Mobile devices have forever altered the way we search, discover and buy from brands. As we spend more and more of our lives using mobile phones, our behaviour is shifting to an always-online mindset, allowing us to shop from wherever we are. But despite an astounding 95% of UK citizens who are using smartphones (Statistica, 2018), mobile commerce (m-commerce) is still low, particularly when compared to the developing markets like China and Africa where mobile payments are the norm. This is set to change fast. Predictions suggest that mobile commerce will overtake desktop soon. Affiliate marketing platform Criteo reported that in the US only 33% of all e-commerce transactions were fulfilled on desktop in 2017, against a towering 59% on mobile. eMarketer, meanwhile, estimates that 59% of global e-commerce sales occur on mobile devices, with the prediction of rising to 73% by 2021 (Kickert, 2019). Social media already act as a space for inspiration, so stumbling across an item on Instagram and purchasing it in a few simple steps seems not only closer than ever, but the desired future. This points to the evolving role of social media, from a place for fun where advertising is at best tolerated to the one where product communications are not just native but welcomed. Platforms are in an arms race, competing to optimize social shopping on

a grander scale, easing the discovery process and reducing the number of steps to purchase. From product tagging to buy buttons, social media platforms are opening their APIs to reduce friction and provide a more seamless shopping experience. As consumers continue to embrace mobile shopping, the power of social media to influence purchase decisions will only increase. Social platforms will, without doubt, continue to introduce new features on their way to achieving true direct social-to-purchase capabilities. Thinking beyond mere advertising is pivotal. Brands need to ensure they occupy all stages of the social shopping journey with relevant content, integrating a shopper focus into their existing social strategy.

## **5. FUTURE OF RETAIL**

While it is true that clicks have not overtaken bricks in total retail sales, e-commerce has fundamentally changed consumer behaviour and heightened their expectations for customer experience. Claiming just 8.9 percent of total retail sales in 2017, according to the U.S. Department of Commerce, e-commerce is still a relatively small bite of the overall retail pie (Church & Oakley, 2018). Online retailers like Amazon.com and Etsy are having an outsized impact on the broader retail market. That impact is multifaceted: online retailers are taking up market share while pushing brick-and-mortar retailers to innovate and transform their businesses for the digital era. Those that say that brick-and-mortar retailers are on their way out are not looking at the bigger picture. The reality is that brick-and-mortar retail is evolving in response to changes in the market. In fact, as many e-commerce players open their own brick-and-mortar stores (think Amazon Go), it is clear that competition and the increasing need for omnichannel platforms to reach customers are shaking up retail in a big way. Even Amazon founder Jeff Bezos realized that. So it is no wonder that Amazon also opened their own stores. Well aware that the FMCG sector is very competitive – especially with heavyweights like Walmart (which is the world's largest brick-and-mortar retailer), Costco, Lidl and Aldi (European chains that opened stores in the US) etc. - Amazon's strategy is aimed more at disruption than competition. **JUST WALK OUT TECHNOLOGY** - the key phrase used for Amazon's cashier-less convenient stores, Amazon Go. These stores resemble the look of normal convenience store, but customers do not need to wait or scan to pay; they just have to walk out the store with items. In order to successfully achieve this, Amazon Go stores have to (and with extremely high accuracy) – register a customer, track the customer's location, detect an item that was picked up, detect an item that was put back onto the shelf, detect when the customer leaves the store. All of this is achieved by hundreds of cameras mounted on the ceiling; they are RGB cameras for tracking individual customers. Amazon has mentioned that their Go stores do not use any facial recognition technology. Instead, these cameras detect each customer's general profile and track individuals with motion detection.

Although Amazon still needs people to staff certain positions in the stores – as they are still an early initiative, it is worth noting out that there are analyses which predict that these stores bring in more revenue per square feet of the store than *conventional* retailers. For instance, RBC Capital Markets analysts found that Amazon Go brings in about 50% more revenue compared to the traditional convenience stores. Considering that Amazon plans to open about 3.000 new stores in the next 2 years (Walmart has about ~4.500 stores), it is hard to predict how the world of brick-and-mortar retail is going to look like in 10 years (Berg & Knights, 2019). Besides brick-and-mortar stores, Amazon is aiming at another segment/opportunity – Amazon Prime Air. Amazon Prime Air is an electric drone program that will drop small packages directly to customers' doorsteps. Fully electric and autonomous, the drone can fly up to 15 miles and deliver packages weighing less than 2.2 kilograms to customers in less than 30 minutes. When in transit, the drone uses diverse sensors and advanced algorithms, such as multi-view stereo

vision, to detect static objects like a chimney. To detect moving objects in the air, like a paraglider or helicopter, it uses computer-vision and machine-learning algorithms.

When approaching the ground for delivery, the drone employs stereo vision alongside AI algorithms that are trained to detect people, animals and obstacles from above. It uses Amazon's self-developed computer-vision techniques to recognize and avoid any hard-to-see obstacles like clotheslines, telephone wires or electrical wires that may cross customers' gardens. Amazon also hopes to use Prime Air as a more sustainable alternative to ordinary delivery options like vans, saving on fuel usage and reducing emissions, not to mention that it is more time and cost efficient. At the moment, a small flat-rate box costs as much as \$10 to send via commercial priority mail and takes at least a day to arrive. A better point of comparison, though, is looking at what it currently costs to have a human provide a quick, short-distance delivery via a food delivery app - For example, UberEats drivers in London receive a minimum of £5.33 (\$6.95) per delivery. This figure does not include what a service like UberEATS also charges the restaurants. It is theoretically possible drones would not only deliver items faster, but at only a fraction of what it costs to have it sent by regular human delivery drivers. Presumably, if delivery can be made faster and dramatically cheaper, more people would order goods and food online.

## 6. CONCLUSION

The world of retail is at a crossroads. Technological advances and the internet have changed the behaviour of consumers and the way companies sell their products to them. While traditional/conventional retail is still the norm and is generating most of the revenue, newer generations (Gen Z for instance) are favouring newer sales channels and are pushing e-commerce, m-commerce and social commerce onto the forefront of retail. Still, companies will have to rely on traditional brick-and-mortar locations for most of their revenue, but due to a handful of companies in the world (i.e. Amazon) even that experience is changing to a way never seen before. It won't be long before the way people shop is completely different compared to as it was 50 years ago.

## LITERATURE

1. Baines, J., & Edwards, P. (2018). The role of relationships in achieving and maintaining a social licence in the New Zealand aquaculture sector. *Aquaculture*, 485, 140-146.
2. Balcerowska, J. M., Bereznowski, P., Biernatowska, A., Atroszko, P. A., Pallesen, S., & Andreassen, C. S. (2020). Is it meaningful to distinguish between Facebook addiction and social networking sites addiction? Psychometric analysis of Facebook addiction and social networking sites addiction scales. *Current Psychology*, 1-14.
3. Berg, N., & Knights, M. (2019). *Amazon: How the World's Most Relentless Retailer will Continue to Revolutionize Commerce*. Kogan Page Publishers.
4. Bureau of Labor Statistics, Current Employment Statistics Highlights. URL: [bls.gov/ces/publications/highlights/2019/current-employment-statistics-highlights-08-2019.pdf](https://bls.gov/ces/publications/highlights/2019/current-employment-statistics-highlights-08-2019.pdf)
5. California State University Long Beach, Subscription to fee-based online services: what makes consumer pay for online content? URL: <http://web.csulb.edu/journals/jecr/issues/20054/paper4.pdf>
6. Church, E. M., & Oakley, R. L. (2018). Etsy and the long-tail: how microenterprises use hyper-differentiation in online handicraft marketplaces. *Electronic Commerce Research*, 18(4), 883-898.
7. CreditDonkey, Infographic: Household Spending Statistics. URL: <https://www.creditdonkey.com/where-money.html>

8. DigitalCommerce360, A decade in review: Ecommerce sales vs. retail sales 2007-2018.  
URL: <https://www.digitalcommerce360.com/article/e-commerce-sales-retail-sales-ten-year-review/>
9. Eurostat, E-commerce statistics for individuals.  
URL: [https://ec.europa.eu/eurostat/statistics-explained/index.php/E-commerce\\_statistics\\_for\\_individuals#General\\_overview](https://ec.europa.eu/eurostat/statistics-explained/index.php/E-commerce_statistics_for_individuals#General_overview)
10. Eurostat, Online shoppers & e-purchases.  
URL: <https://ec.europa.eu/eurostat/cache/infographs/ict/bloc-2a.html>
11. Forbes, Alibaba's 'New Retail' Revolution: What it is, And Is It Genuinely New?  
URL: <https://www.forbes.com/sites/jonbird1/2018/11/18/alibabas-new-retail-revolution-what-is-it-and-is-it-genuinely-new/>
12. Graff, M., Miranda-Jimenez, S., Tellez, E. S., & Moctezuma, D. (2020). EvoMSA: A Multilingual Evolutionary Approach for Sentiment Analysis [Application Notes]. *IEEE Computational Intelligence Magazine*, 15(1), 76-88.
13. Investopedia, How do subscription business models work?  
URL: <https://www.investopedia.com/ask/answers/042715/how-do-subscription-business-models-work.asp>
14. Kickert, C. (2019). What's in store: prospects and challenges for American street-level commerce. *Journal of Urban Design*, 1-19.
15. Makridakis, S. (2017). The forthcoming Artificial Intelligence (AI) revolution: Its impact on society and firms. *Futures*, 90, 46-60.
16. Maraz, A., Griffiths, M. D., & Demetrovics, Z. (2016). The prevalence of compulsive buying: a meta-analysis. *Addiction*, 111(3), 408-419.
17. MarketingLand, Instagram debuts in-app checkout for e-commerce brands.  
URL: <https://marketingland.com/instagram-debuts-in-app-checkout-for-e-commerce-brands-258587>
18. Medium, Can Anyone Catch the Cellphone King.  
URL: <https://medium.com/herenews/can-anyone-catch-the-smartphone-king-557baf09cb9f>
19. Mushtaq, M. S., & Mellouk, A. (2017). *Quality of Experience Paradigm in Multimedia Services: Application to OTT Video Streaming and VoIP Services*. Elsevier.
20. Onden, A., & Kiygi-Calli, M. (2018). THE EFFECTS OF BRANDS'POSTS ON SOCIAL MEDIA: CONCEPTUAL FRAMEWORK AND APPLICATION METHOD. *Research Journal of Business and Management*, 5(3), 238-250.
21. Pham, Q. T., & Tran, N. K. P. (2020). The impact of incentive mechanism and knowledge sharing motivation on the satisfaction of fanpage's members on Facebook in Vietnam. *International Journal of Entertainment Technology and Management*, 1(1), 64-79.
22. Poulfelt, F., Olson, T. H., Bhambri, A., & Greiner, L. (2017). The changing global consulting industry. In *Management consulting today and tomorrow* (pp. 5-36). Routledge.
23. PuaSchunder, J. M. (2019). *Intergenerational Equity: Corporate and Financial Leadership*. Edward Elgar Publishing.
24. Rishi, B., Kapoor, A., & Bhatia, S. (2016). AaramShop. com reinventing the e-grocery wheel in India. *Emerald Emerging Markets Case Studies*.
25. Thang, S. M., & Ng, L. S. (2020). Influence of Age Groups and School Types on Informal Learning Through the Use of Social Networking Sites. In *Recent Developments in Technology-Enhanced and Computer-Assisted Language Learning* (pp. 30-47). IGI Global.
26. VARDARLIER, P. (2020). Digital Transformation of Human Resource Management: Digital Applications and Strategic Tools in HRM. In *Digital Business Strategies in Blockchain Ecosystems* (pp. 239-264). Springer, Cham.

27. Wang, Z., & Kim, H. G. (2017). Can social media marketing improve customer relationship capabilities and firm performance? Dynamic capability perspective. *Journal of Interactive Marketing*, 39, 15-26.
28. Yeh, C. H., Wang, Y. S., Hsu, J. W., & Lin, S. J. (2020). Predicting individuals' digital autpreneurship: Does educational intervention matter?. *Journal of Business Research*, 106, 35-45.
29. Zhang, L. (2020). When Platform Capitalism Meets Petty Capitalism in China: Alibaba and an Integrated Approach to Platformization. *International Journal of Communication*, 14, 21.



## GLOBALIZATION OF THE ECONOMY AND ITS IMPLICATIONS

**Khankishi Khankishiyev**

*Azerbaijan State University of Economics (UNEC)*

*Baku, Istiqlaliyyat str.6, AZ1001, Azerbaijan*

*khanbiznes@rambler.ru*

### **ABSTRACT**

*The article discusses the globalization of the world economy in the process of changing the world space, transforming it into a single zone, opening for the unhindered movement of goods, services, information, capital. It is also easy to spread ideas and carriers in this space, contributing to the development of relevant institutional formations and setting up systems of interaction between them. The consequence of globalization of world systems in this way is the emergence at the international level of a single space: cultural, informational, legal and economic. In other words, the phenomenon of globalization is not limited to the sphere of the economy, but to a large extent affects all key areas of society - ideology, culture and politics. Without a doubt, this phenomenon has been given a central role in the global economy of the new century, which consists in catalyzing the formation of an updated world system of relations in politics and economics adapted to globalization. One of the problems of globalization is potential global instability due to the interdependence of national economies at the global level. As a result, local economic fluctuations or crises in one country can have regional or even global consequences. The negative aspects of globalization are associated with the potential conflicts it is fraught with, although they can be mitigated by developing global cooperation based on political agreements or creating new international institutions. The globalization of the global economy has an impact on all states, in particular, determining the development and diffusion of technologies between countries, the use of labor, the manufacture of goods and the offer of services and investments. As a result, such parameters as competitiveness, labor productivity and production efficiency as a whole change.*

**Keywords:** *globalization, internationalization, global instability, integration, national production*

### **1. INTRODUCTION**

Globalization of the world economy is expressed in the process of changing the global space, transforming it into a single zone, opening for the unhindered movement of goods, services, information, capital. It is also easy to spread ideas and carriers in this space, contributing to the development of relevant institutional formations and setting up systems of interaction between them. The consequence of globalization of world systems in this way is the emergence at the international level of a single space: cultural, informational, legal and economic. In other words, the phenomenon of globalization is not limited to the sphere of the economy, but to a large extent affects all key areas of society - ideology, culture and politics. Without a doubt, this phenomenon has been given a central role in the world economy of the new century, which consists in catalyzing the formation of an updated world system of relations in politics and economics adapted to globalization. One of the key processes in the development of the global economy is progressive globalization, i.e. a qualitatively new stage in the development of the internationalization of economic life. The attitude to globalization of both specialists and all the inhabitants of our planet is very ambiguous, and sometimes diametrically opposite. This is due to different points of view on the consequences of globalization processes, in which some see a serious threat to the global economic system, while others see a means of further economic progress. Undoubtedly, the consequences of globalization can be both positive and negative, but there is no alternative to it, and therefore the main attention in the article is devoted to the

study of the dangers (threats) that these processes bear and the opportunities and benefits that arise in the process of globalization. As a result of international production cooperation, the development of the international division of labor, foreign trade and international economic relations as a whole, the interconnection and interdependence of national economies is strengthened, the normal development of which is impossible without taking into account the external factor. The next stage was international economic integration, objectively determined by the deepening of the international division of labor, the internationalization of capital, the global nature of scientific and technological progress and an increase in the degree of openness of national economies and free trade.

## **2. CHAPTER I**

International economic integration is a fairly high, efficient and promising stage of development of the world economy, a qualitatively new and more complex stage of the internationalization of economic relations. At this stage, there is not only a rapprochement of national economies, but also a joint solution of economic problems. The processes of economic integration are ongoing both bilaterally and regionally or globally [2]. Globalization has become the most important real characteristic of the modern world system, one of the most influential forces that determine the course of development of our planet. The processes of global development, within which the structures of national production and finance become interdependent, are accelerated as a result of an increase in the number of concluded and implemented external transactions. Globalization, covering all regions and sectors of the world economy, fundamentally changes the relationship between external and internal factors of development of national economies in favor of the former. No national economy, regardless of the size of countries (large, medium, small) and level of development (developed, growing or transitional) can no longer be self-sufficient, based on existing factors of production, technology and capital requirements. Not a single state is able to rationally formulate and implement an economic development strategy without taking into account the priorities and norms of behavior of the main participants in world economic activity. Although the concept of “globalization” has recently been the most frequently encountered in economic literature, it is still very far from the full clarity of this term both in conceptual and in practical terms. Globalization processes are mixed. We give only two points of view. Professor of Sociology, University of California (USA) M. Castells defined globalization as the “new capitalist economy”, listing the following as its main characteristics: knowledge and information technologies are the main sources of productivity growth and competitiveness; this new economy is organized mainly through the network structure of management, production and distribution, rather than individual firms, as before; and it is global [1].

The globalization process covers various areas of the global economy, namely:

- foreign, international, world trade in goods, services, technologies, intellectual property;
- international movement of factors of production (labor, capital, information); international financial and credit and foreign exchange operations (gratuitous financing and assistance, loans and borrowings of subjects of international economic relations, operations with securities, special financial mechanisms and instruments, operations with currency);
- industrial, scientific, technical, technological, engineering and informational cooperation.

In the visible future, globalization is projected to entail:

- intensification of regional integration processes;

- greater openness of the economic systems of states that currently have not yet fully liberalized their economic activities; unhindered access for all participants to any markets;
- universalization of norms and rules for the implementation of trade and financial operations; unification of regulation and market control; standardization of capital transfer requirements, the investment process and the global payment and settlement system.

It has been established that a characteristic feature of globalization in the economy is a combination of processes of autonomy and integration. This is reflected in the “Nesbit paradox”: “The higher the level of globalization of the economy, the stronger its smallest participants” J. Neysbitt notes the movement, on the one hand, to political independence and self-government, on the other, to the formation of economic alliances [1]. Consequently, the paradox of globalization is that the richer and stronger the internal ties of society, the higher the degree of its economic and social consolidation, and the more fully its internal resources are realized, the more successfully it is able to take advantage of integration ties and adapt to the conditions of the global market. Given the uneven distribution of the benefits of globalization, of course, the negative consequences of globalization processes in a particular country will significantly depend on the place that this country occupies in the global economy. In this regard, we distinguish three groups of threats, dangers, potential problems that arise at the present stage of development of the internationalization of economic activity, depending on which countries they can spread to. The most painful consequences of globalization can be felt by less developed countries belonging to the so-called world periphery. The bulk of them, participating in internationalization as suppliers of raw materials and manufacturers of labor-intensive products (and some of them as suppliers of parts and assemblies for modern complex equipment), are fully dependent on advanced powers and have incomes, firstly, smaller ones - second, very unstable, depending on world market conditions. As already noted, the largest benefits from participating in globalization are industrialized countries, which are able to reduce production costs and focus on the production of the most profitable high-tech products, transfer labor-intensive and technologically dirty industries to developing countries. But industrialized countries can also suffer from globalization processes, which, if not managed, will increase unemployment, increase the instability of financial markets, etc. A significant problem is that the uneven distribution of benefits from globalization is observed not only in individual countries, but also in the context of individual industries. The sectors that benefit from foreign trade and the export-related industries experience a greater influx of capital and skilled labor compared to a number of industries that significantly benefit from globalization processes, losing their competitive advantages due to increased market openness. Such industries are forced to make additional efforts to adapt to the changing economic conditions that are not in their favor; there is an outflow of capital and a reduction in jobs.

### **3. CHAPTER II**

Many call the deindustrialization of the economy a threat, since globalization processes are associated with a decrease in employment in manufacturing industries both in Europe and in the USA. And deindustrialization is the cause of the emergence of depressed regions, strengthens the social stratification of society. Indeed, the share of manufacturing industries in the economies of industrialized countries is sharply declining, but it should be noted that this decline is offset by the rapid increase in the share of services, including the financial sector. The growing global integration of capital markets threatens the economic policies of individual countries, as foreign capital in the form of direct or portfolio investments poses a certain threat to the national economy due to the ability to disappear from the country as quickly as it appears.

Globalization reduces the ability of governments to maneuver. Soon they will be confronted with the need to combine efforts to control the international activities, information and financial networks of TNCs. As a threat, one can note, in particular, the potential increase in unemployment as a result of the transfer by companies of countries with high labor costs of part of their production capacities to countries with low wages. Export of jobs may be undesirable for the economy of several states. But most often in such conditions, companies in developed countries stop producing unprofitable products and switch to the production of goods that require the use of highly qualified personnel. There is a redistribution of labor. The next threat is associated with labor mobility. The mass migration of the population, acquiring a global character, is turning into a serious source of aggravation of the socio-economic situation in the world. The destabilizing factors are new forms of employment (individualization of employment conditions, temporary contracts) and the globalization of the labor market. The influx of cheap labor from outside intensified competition in the labor market of developed countries, which led to the complication of interethnic relations and the growth of nationalism in these countries. The negative consequences of freedom of movement of labor have long been recognized as a potential danger, and today in many countries it is considered quite real. Therefore, almost all states have introduced some form of control over the free movement of labor. But it should be noted that the most trained and highly valuable workforce is more mobile and is able to effectively find its market niche. In the context of globalization, all countries will try to attract talented specialists and skilled workers, willingly providing them with visas and letting them into their market. The emergence of cross-country overflow of labor will lead to a global increase in productivity, since an optimum will be achieved in the distribution of labor resources. One of the problems of globalization is potential global instability due to the interdependence of national economies at the global level. As a result, local economic fluctuations or crises in one country can have regional or even global consequences. The negative aspects of globalization are associated with the potential conflicts it is fraught with, although they can be mitigated by developing global cooperation based on political agreements or creating new international institutions. It is practically impossible to unequivocally answer this question, because the balance of positive and negative consequences is constantly changing. However, "the reality is that globalization is an objective and absolutely inevitable phenomenon of our time, which can be slowed down by the means of economic policy (which happens in a number of cases), but cannot be stopped or " canceled ", for such is the imperative demand of modern society and scientific and technological progress. " [5] Countries need to adequately respond to globalization processes in order to adapt to new conditions and take advantage of the opportunities provided by the internationalization of the global economy.

#### **4. CHAPTER III**

The world economy became an integral system only at the border of centuries (XX and XXI). The main stages of globalization: the first stage in the formation of the modern world economy (XIV - late XIX centuries) is highlighted in connection with the emergence of the global commodity market and world trade, which became the first elements of the globalization of the world economy. The second stage of development of the world economy (late 19th century - early 20th century) can be described as the stage of transition of initial capitalism to the stage of monopolization of production. Also at this time, there is a division of the world territory and zones of economic influence between the leading powers, cross-border capital flows (export) are intensifying. A variety of forms of economic relations between countries is growing: in addition to exchanging goods, migration of individual factors of production between states has also begun to be practiced. At this stage, the fundamental foundations of the international division of labor, as well as the future globalization of world trade, are laid. The third stage on the path to world globalization (the interval between the First and Second World Wars) was

destructive for past successes in establishing world economic relations. Although economic development accelerated significantly during this period (the first international corporations appeared), the financial system at the transnational level is extremely unstable and unstable, long-term capital leaves industrialized countries. The fourth stage (from the end of World War II to the beginning of the 90s) is the period of a new restructuring of the relations of the economic plan between the states, attempts to find a new order for the world economy. The main influence on the international economy is exerted by liberalization of foreign trade policy, growth of labor productivity, acceleration of progress in the field of science and technology and, as a result, an unprecedented economic growth rate. At this stage, the foundation is being laid for globalizing global finance, a macro-system of financial and economic organizations regulating the world economic development (UN, IMF, World Bank and trade organizations of the IB and WTO) is being built. By the 50s, the colonial system was breaking up, regulating the interaction of the metropolises with the colonies. The fifth stage (since the beginning of the 90s) is the current period of development of the world economy. The key factors are the collapse of the socialist system led by the USSR, and, consequently, the transition to a market economy of the former states of the social bloc in Central and Eastern Europe and the remaining colonies, increased openness of the markets of these countries.

Sources of globalization of the global economy are:

1. Globalization is caused by objective factors of world development, a deepening of the international division of labor, scientific and technological progress in the field of transport and communications, which reduces the so-called economic distance between countries. The highly effective telecommunication systems existing today allow users to receive information in real time, wherever they are, which makes it quick and easy to make decisions, manage international capital investments, and cooperate in marketing and production. At the current level of globalization and the integration of information, the rate of transfer of business experience and technology from abroad is growing significantly. There are conditions for the globalization of world processes that previously retained locality due to internal features. Thus, higher education of the first class can now be obtained at a distance from the world's leading educational institutions.
2. Trade liberalization and other forms of economic liberalization, which caused a restriction of protectionism policies and made world trade more free. As a result, a significant part of trade barriers was eliminated; customs tariffs decreased. In addition, due to the application of other liberalization measures, the movement of capital, labor and other factors of production between countries has intensified.
3. The phenomenon of trans nationalization, which leads to the fact that some of the consumption and production, income, as well as import / export of a country are determined beyond its borders by decisions of international centers. The leading position in this system is held by TNCs - international corporations that at the same time act as the main players in internationalization and its result. The globalization of the global economy has an impact on all states, in particular, determining the development and diffusion of technologies between countries, the use of labor, the manufacture of goods and the offer of services and investments. As a result, such parameters as competitiveness, labor productivity and production efficiency as a whole change. The acceleration of the globalization of the global economy has occurred in the last 20-30 years, during which there was an integration of world markets into the TNC network, an increase in the relationship between corporations and the markets for goods, technologies, services, as well as labor. Despite the fact that some transnational corporations limit their activities to trading, most of them require industrial restructuring in developing countries through the modernization of old (food, textile) and the creation

of new industries (electronic, petrochemical, automotive, machine-building). New generation MNCs (known as global corporations) operate primarily in financial and information markets, which distinguishes them from earlier production MNCs. [4] Thus, these markets are united on a planetary scale, the financial and information space in the world becomes one. As a result, the importance of TNCs and international economic organizations and structures associated with them (IMF, IFC, IBRD) is growing. Today, the vast majority of new technologies (80%) are produced by transnational corporations, and the latter have already outgrown the GNI of some countries, and quite large ones. It is significant that in the list of top 100 world economies, ranked by size, 51 place belongs to TNCs. It is noteworthy that for the most part these companies are engaged in the creation of metatechnologies (or hypertechnologies), including modern computer programs, network computers, organization technologies, the formation of mass consciousness and public opinion. The face of the world economy and financial markets today is determined and controlled by the owners and developers of such technologies [3]. About 33% of the income of developing countries and 20% of industrialized countries are directly dependent on exports. About 10-12% of those employed in the service sector and 40-45% in the manufacturing industry are associated with foreign trade, both directly and indirectly. Thus, today foreign trade is the main means of redistributing income in the world. Separate aspects of the impact on national indicators of the globalization process of the global economy should be discussed separately.

Firstly, the growth rate of foreign direct investment today is incredibly high and significantly exceeds world trade. Largely due to these investments, shifts are taking place that directly affect national economies: industrial restructuring and technology transfer, the formation of global enterprises.

Secondly, globalization is affecting technology innovation. This is due to the increase in competition that it causes. Technology, in turn, is the driving force for the very globalization of the world economy.

Thirdly, due to the impact of globalization on the world market, the main factor in trade relations between countries becomes trade in services (managerial, legal, informational, financial, etc.).

As a result of deepening internationalization, one can observe increased interaction and interdependence between the economies of states. Thus, globalization and some kind of integration are taking place, the formation of a single international economic system as a new structure. Despite the fact that most of the produced global product is consumed in the country of origin, the national development of countries is increasingly dependent on global structures, but its diversity and versatility in comparison with the past also grows [3]. The conditions under which globalization is taking place can be described as largely polarized. This is especially true for the distribution of opportunities and economic power in the world system. This situation can lead to conflicts, problems, additional risks. So, only a few leading countries of the global economy in the context of globalization are able to control a large share of consumption and production without any economic or political pressure. The domestic values and priorities of such countries cannot but leave their mark in the leading areas of internationalization.

At the same time, national states represented by transnational corporations acquire powerful partners that must be reckoned with, and sometimes even rivals in the sphere

of influence on the country's economy. The practice of signing agreements between national governments and TNCs on the terms of cooperation is generally accepted. At the same time, non-governmental organizations, like global corporations, have reached a global, international level, which has opened up new opportunities for them. In the context of globalization of world finance, the role of organizations such as the IMF, WTO, UN and the World Bank has grown. That is, both state and private companies and organizations of an international scale have become key players in the globalized world economy.

4. Achieving global unanimity in assessing a market economy and free trade system. This process was launched in China in 1978 along with the reform, after which the collapse of the USSR and significant changes in the policies and economies of CEE countries took place. A consequence of the development of the process was the convergence of socialist and market ideologies, the contradictions between them gave way to a practically unified view of the market approach to the economy. A natural consequence of this convergence was the transition of the countries of the socialist camp to a market concept in the economy. However, the success of such a transition in CEE and CIS countries may be called into question.

Among the main conditions for the transition to a market economy, which were chosen as a guide by the governments of the reformed states and their partners from developed countries and international organizations, were liberalization of prices, privatization of state companies and economic stabilization at the macro level. At the same time, the creation of conditions for competition and specific market institutions faded into the background, and the unique role assigned to the government in a mixed economy was not taken into account.

5. Features of cultural development. In the context of globalization, a tendency towards homogeneity in mass art, popular culture and the media, the spread of English as lingua franca has been established. Another feature of the globalization of the world economy, which cannot be ignored, was development at the end of the 20th century. financial markets at a cosmic pace. The changing role of credit, foreign exchange and stock markets during this period led to shifts in the architecture of the entire international economy. A couple of decades ago, the main objective of financial markets was to meet the needs of the real sector, but today finance is less dependent on production. Together with the liberalization of the economy, this led to increased speculation in the market, which resulted in a multiple increase in its volume. Simply put, in modern conditions, the process of extracting money from money has become much easier, because the stage of production of goods or services can be excluded from it. Instead of the latter, the source of profit was the game on fluctuations in exchange rates and speculation with derivative financial instruments (options, futures, etc.).

The process of internationalization in the financial market can be called the most advanced and most complex of the global economies that take place within the framework of globalization; it was the result of strengthening financial ties between countries, the formation of TFGs operating on a global scale, more liberal rules for pricing and moving investment flows. The relative growth rate in the transnational capital market of loan volumes in the last 10-15 years was a record + 60% compared to foreign trade and + 130% compared to VMP.

## 5. CHAPTER IV

The number of investing companies operating in the international market is growing. It is the globalization of world finance that is often blamed for the diversion of capital from the real sector and the growth of speculation, a decrease in its participation in the creation of new jobs and industries. The centers for the globalization of global finance are the three largest economies: the USA, Western Europe and Japan. However, financial speculation extends far beyond the designated regions. The daily turnover in the global foreign exchange market is about \$ 1 trillion. Due to the influx of speculative capital into any country, its position may be destabilized, and the amount of funds received will be much larger than necessary. The existing high rates of globalization in global finance are still the key cause of risks and vulnerabilities in the global economy, in particular, the integration of markets increases the likelihood of systemic failures [4].

The advantages of globalization of the world economy are:

1. International competition, the product of globalization, is a powerful stimulator of production. Fierce competition leads to an increase in the quality of manufactured goods and services. This happens naturally due to the desire of companies to take a better place in trade internationally. In this regard, they are simply forced to make more attractive products relative to competing firms.
2. In the context of globalization of the world economy, economies of scale are achieved, which leads to lower prices and mitigate changes in economic cycles.
3. The benefits that globalization of world trade brings to all its participants are undeniable. In turn, the formation of trade unions leads to an increase in the pace of globalization.
4. Labor productivity is growing due to the introduction of new technological solutions.
5. Developing countries have the opportunity to catch up with the leading economies, due to the globalization of the world economy, they have some head start and time to strengthen their own economic situation in the world market.

The disadvantages of world globalization are that:

1. The distribution of the positive effects of globalization of the world economy is uneven. Thus, in the context of industries, some of them benefit: from abroad come personnel with the necessary qualifications and additional financing, but others lose in competitiveness, the need for them decreases. Sectors from the last list require additional funds and time for restructuring and adaptation. Adaptation often fails. In this case, employees lose their jobs, and entrepreneurs business and money. Changes in this plan affect the national economies of individual countries, lead to increased unemployment and forced changes in the structure of the economy.
2. The continuation of the previous trend can be called the phenomenon of de-industrialization of the economy. The balance in this case is shifting from manufacturing to services. Local cadres often need to be retrained in order to adapt to the changes caused by the globalization of the world system, to change their qualifications in order to find a new job in another industry.
3. A growing gap in the remuneration of workers with and without qualifications. While the salaries of educated employees are growing, unskilled personnel are forced to be content with a very modest pay, if there is any work left for them. The unemployment generated by this process has a bad effect on the reputation of world globalization. However, with a different view, it acts as an incentive for the development, training and advanced training of employees.
4. Under the influence of world globalization, the ecosystem is changing, the likelihood of conflicts over the ownership and use of natural resources is growing. The main reason



for such conflicts may be the irrational use of forest, water and other resources. The harm that such activities do to the planet and its inhabitants can be irreparable.

The ongoing and interconnected processes of regionalization and globalization of the world economy lead, first of all, to the growth of contradictions between the countries of the North and South. In the framework of the global economy, which currently consists of the enrichment of transnational corporations, states and other economic agents from North America and Europe, it flows predominantly unidirectional. At the same time, the peripheral countries of the South (conditionally the “third world”) are gradually becoming hostages of the world system and globalization processes, since the gap in development between them and the countries of the North is only growing. Note that the reaction to such a situation is far from calm everywhere [5].

Thus, the majority of terrorist groups in their ideology have an element of orientation against world globalization, have a pronounced anti-Western movement, which allows them to clearly indicate their position in the space of world ideology and politics. The global goals that terrorism sets itself are consonant with the era as a whole. Among them, for example, opposition to the federalization of the EU or Western civilization as a whole. Having set such tasks for themselves, such groups have no problems attracting people to their side, since the latter easily follow ideological clichés of an anti-Western orientation. The propaganda of terrorist approaches in politics and radicalism does not miss the opportunities that the media provide today in terms of global audience accessibility and the creation of an “effect of presence”.

The structure, in which the liberal market of skilled personnel is located in the center, and on the periphery the much less free market of less skilled workers, is fundamental for capitalism in the context of the globalization of the world economy. The fact is that without unevenness, inequality between the elements of the system, it simply cannot function, and there will also be no reason for integration. Among the new contradictions of the era that are not easy to resolve, including the dilemma of creating a post-industrial economy with high employment at the same time. Indeed, in the conditions of application of modern IT, which is characteristic of the post-industrial world, the need for the same amount of labor disappears. However, this is precisely the resource that the countries of the South have in abundance.

Due to the fact that the processes of globalization of the world economy, modernization and nation building take place in the countries of the periphery at the same time, the accompanying contradictions and problems overlap and mutually reinforce. As a result, most of the states located outside the center, not belonging to the narrow circle of nuclear powers of the West, are becoming outsiders in the political and economic arena. Among the causes of emerging problems can be identified:

- The rapid reduction of resources for state policies to curb social stratification within countries, the implementation of appropriate economic and social measures);
- Strengthening the financial dependence of all on all;
- Growth of state inefficiency as a result of global economic rationalization;
- Strengthening the influence of Western consumption standards (through the media), which lead to a “revolution of rising expectations,” since in fact a similar level for most countries is not achievable.

The end of the Cold War has become a key factor in the revival of ethnic nationalism. During the existence of the USSR and the USA and the confrontation between them, the latter was a defining and formative phenomenon for many conflicts in third world countries. Since today

this confrontation is no longer relevant, and the influence of the factor has waned, the topic of conflicts on the periphery has shifted to the field of interethnic relations. There is a noticeable relationship between the growth of mass nationalism and the globalization of world development, the spread of freedom of the press, speech, democracy in general. Since at the initial stage of such a transition democratic institutions are still ineffective, on their basis the prerequisites for the growth of nationalist sentiments are formed. In particular, a similar scenario of a conflict is most likely in a situation where the elite's perception of rapidly occurring changes in the political system is inadequate, namely, they see a threat to the current privileged position. Other components of the situation are a premature increase in the participation of the masses in the political process (before the creation of civil society institutions), political mobilization of the masses on a discriminatory basis (based on ethnicity).

On the contrary, the factors that constrain such conflicts are the competent policy of the elite in the development of "civil nationalism" and liberal institutions. The first, we note, prevails over the latter, that is, even with weak institutions, but the formation of "civic nationalism" the success of democratic reforms is likely. A number of Islamic authors of our time, originating from the raw materials of the Middle East, consider Western colonization to be the cause of the current world system with its inherent globalization, and therefore do not accept the order. The additional sources of irritation in this case are the imposition of Western culture, which poses a danger to Islamic culture, and especially the globalization of the world economy, which from their point of view is unfair. According to fundamentalists and Islamists, today all the problems of Islamic states are associated with the borrowing of foreign customs and concepts alien to them. Departure from true Islam led them to lose their former greatness. The influence of such a fundamentalist doctrine, which completely rejects the Western model in politics, unfortunately, is growing.

The new world order and the challenges of the modern world. Models of a unipolar and multipolar world. The basis for the formation of a new model of the world (IMF, the new world order) was the collapse of the previous bipolar system. Since the main problem - the prevention of nuclear war, which worried everyone for 50 years, is gone, other equally important alternatives came to the fore:

- Achieving socio-political stability through improving the quality of life, economic growth and optimizing the economy;
- Ensuring world security through limiting the activities of terrorist movements, neutralizing threats emanating from dictators with a strong army and resources;
- Increasing the controllability of development processes, namely, the best controllability of complex social and technical systems (nuclear power plants, IT).

You may notice that in order to solve such problems, it is necessary to unite the efforts of all countries and organize a new effective decision-making mechanism that allows solving problems in the context of globalization of world interdependence. Such a mechanism should be fundamentally different from the previous version, aimed at blocking the activity of individual countries (for example, potentially leading to an escalation of tension around nuclear weapons). Thus, the NMP will become a decision-making mechanism aimed at solving the problems of mankind, among which are the global consequences of globalization. In addition, globalization has become one of the key global trends in society today. Aspects in which individual societies are firmly connected among themselves are numerous: cultural, economic, political. The global scale of such interdependencies is obvious. Today, humanity is being transformed into a new all-encompassing integrity of a social nature. The concept of globality combines many factors and elements that make up the world system, humanity as a whole and

the individual, the future and the present, the results and actions that caused them. We can observe the structure at the global level, uniting societies into a system through cultural, political and economic relations. In the field of politics, the manifestation of this trend is the formation of supranational communities, varying in scale. These are regional or continental associations, and military-political blocs, and world-wide international organizations, and coalitions of ruling elites. In cases where part of the key functions is transferred to supranational organizations, we can talk about the formation of a world government (Interpol, European Parliament). In the field of economics, the importance of agreements concluded at the regional and world level, integration and coordination, which is carried out at the supranational level, is growing. In addition, the influence of TNCs and MNCs is growing, brighter than before the international division of labor was expressed. The speed with which information from individual countries is reflected in the movements of financial markets allows us to talk about the world market as a single global mechanism of the economy.

## 6. CONCLUSION

In terms of globalization of culture, a key global trend is the pursuit of uniformity. Thanks to the actions of the media, the entire planet becomes a "big village." Due to the dissemination of information about the same events in different parts of the planet, reached by millions of people around the world, the cultural experience becomes one for all, therefore, the preferences and tastes of people are unified. The global consequences of globalization include the growing relevance of environmental issues, which is largely due to the rapid development of production. In modern conditions, when the environment surrounding a person is actively being destroyed, the emphasis shifts from the problem of protecting a person from natural phenomena, the elements to protecting nature itself from human exploitation and its technological interference. Also, modern weapons systems have reached the level of technology perfection sufficient to destroy all the inhabitants of the earth. Thus, as never before, coordination of the joint efforts of all countries both in the field of environmental, environmental protection activities and in the field of peacekeeping is now necessary. The modern scientific worldview must be redesigned to become a worthy answer to such trends. So, the report "The First Global Revolution", voiced at a meeting of the Club of Rome, stated the need for the formation of a civilization with the ability to consciously and holistically manage the development of mankind. Only in this way is it possible to reverse the global trends caused by globalization that threaten us all. In the current era of such a rapid development of scientific and technical progress, the existence of countries without active interaction between them is simply impossible. Such interaction can occur both through political and economic channels. So, in the sphere of interests of international organizations are not only relations between states, but also many issues that have become relevant in the process of world globalization, for example, environmental, peacekeeping, resolving economic crises and combating epidemics of drug addiction or AIDS. In the context of globalization of world interaction, an international organization (International agency) is an association of non-governmental or intergovernmental nature, functioning on an ongoing basis, based on an international agreement, whose activities are aimed at facilitating the speedy resolution of a number of international problems specified in such an agreement. International organizations are characterized by:

Regular / ongoing nature of activities;

The constituent document on which the activity is based;

Multilateral negotiations and discussion of problems as the main method of work;

The advisory nature of decisions;

Adopting them by consensus or voting.

Regional and global, non-governmental and intergovernmental international organizations are distinguished.

One such international organization in the era of globalization is the World Trade Organization (WTO), which was established in 1995. It is busy setting the rules for international trade. The basis of this organization is the agreement, which most of the countries participating in international trade have agreed, signed and ratified among themselves. The ultimate goal of the WTO is to help exporters and importers, producers of services and goods to conduct business in the context of globalization of world trade. Today, up to 95% of the volume of international trade (in value) is regulated by the rules established by the WTO. Another global organization, the Organization of the Petroleum Exporting Countries (OPEC), is a cartel created in 1960 by a number of oil producing countries to monitor global oil prices and coordinate its production in the context of globalization of the global economy. This organization sets quotas on the volume of oil produced. Its members today are: Libya, Nigeria, Qatar, Algeria, Indonesia, Kuwait, Saudi Arabia, Iran, Iraq - only 11 countries [6]. In 1945, the International Bank for Reconstruction and Development (IBRD, World Bank Group) was established in Washington. Its goal was to help the development of those Member States that were not able to attract private capital on favorable terms through lending. Also in 1945, the International Monetary Fund (IMF) was created, the purpose of which was to ensure the stability of the foreign exchange market in the context of globalization of world finances, and to intensify cooperation in international trade and finance at the international level. The headquarters of these organizations are located in Washington and Rome.

**LITERATURE:**

1. The post-industrial world and the processes of globalization // World Economy and International Relations. M., 2009.
2. Koch R. Management and finance from A to Z. St. Petersburg: Publishing house "Peter", 2008.
3. Ivanov N. Globalization and problems of the optimal development strategy // World Economy and International Relations. M., 2010.
4. Dolgov S.I. Globalization of the economy: a new word or a new phenomenon? M., 2008.
5. The post-industrial world and the processes of globalization // World Economy and International Relations. M., 2005.
6. [www.opec.org](http://www.opec.org)

# UPM BIO VERNO: BIODIESEL PRODUCED FROM THE BY-PRODUCT OF THE PULP INDUSTRY AND ITS IMPORTANCE IN GREEN MARKETING AND STRATEGY

**David Vrtana**

*University of Zilina, Faculty of Operation and Economics of Transport and Communication  
Department of Economics, Univerzitna 8215/1, 010 26 Zilina, Slovak Republic  
david.vrtana@fpedas.uniza.sk*

**Anna Krizanova**

*University of Zilina, Faculty of Operation and Economics of Transport and Communication  
Department of Economics, Univerzitna 8215/1, 010 26 Zilina, Slovak Republic  
anna.krizanova@fpedas.uniza.sk*

## **ABSTRACT**

*Nowadays, green marketing is irreplaceable and its correct application can significantly help to fulfill the marketing strategy. Green solutions for business and industry can also have a significant impact on some form of corporate social responsibility by which a business can increase its competitiveness in a market environment. The subject of the article is a Finnish company operating in the forestry industry. The article contains three basic areas, which will be described with respect to effective implementation of marketing strategy. It will be a general description of biofuel production, including aspects relevant to distribution planning and economic governance. It will also describe the basic customer aspects, including identifying the challenges of biofuel producers in local, European and global markets in the context of UPM. We also identify the positive and negative aspects of biofuels for private and truck users. The conclusion of the analytical part of the article will describe the basic marketing and distribution plans that UPM BioVerno should make in case of entering the domestic market. On the basis of all the information from the analytical part, we proceed to the discussion part in which we will describe the relationship between the use of palm oil and other vegetable oils for the production of biofuels and thus the use of rare fertile land for biomass cultivation. We also describe why wood waste is used in Finland and on the basis of the analyzed data we will try to show whether a similar business would work on the domestic market. In the final part we will summarize the importance of green marketing and its relation to marketing strategy to the company and in general.*

**Keywords:** *UPM BioVerno, marketing strategy, green marketing, customer, biofuels*

## **1. INTRODUCTION**

We must find alternative solutions for the fossil fuels. Even if it would be so that the fossil fuels will never run out but their price will rise unreasonably high. From the point of view of sustainable development and order for example to reduce the carbon footprint, the transition to alternative fuels or electricity is necessary. The production of biofuels and other sustainable development of fuel products should contribute to climate change such as fossil fuels, not lead to deterioration and destruction of biodiversity. Biofuel customers are expecting that bio fuel is the same kind of product as normal fossil fuel product. It has the same or close consumption values. Bio fuel should not harm the engine in car in any circumstances. Bio fuel efficiency should be in the same level as normal fuel.

## **2. UPM BIOVERNO AND DECISIVE ASPECTS WHEN PLANNING THE LOCATION OF THE REFINERY**

As already mentioned in the abstract UPM BioBerno is a Finnish company operating in the forestry industry. UPM products are made of responsibly sourced, renewable raw materials. The company produce products which include pulp, paper, sawn timber, labels, plywood and composites, bioenergy and biofuels for transport, nano products and biochemical. UPM takes the first place to produce graphic papers in the world and the second place to produce self-adhesive label materials. The Finnish company employees approximately 20 000 people. UPM has production plants in 14 countries and it has a worldwide sales network. UPM's production plants are located in Brazil, Uruguay, Finland, Estonia, Germany, Poland, Spain, Russia, UK, USA and Malaysia. UPM BioVerno is a brand new renewable diesel that has been produced in Finland from mostly domestic raw materials. It can be directly used in all diesel engines. The biofuel is based on UPM's own innovations; it is derived from crude tall oil, a residue of pulp production. Because of its significant environmental benefits, UPM BioVerno is a responsible choice. (Annual report, 2019, p. 9 – 20)

UPM BioVerno strives to apply green marketing and thus use waste for the production of biofuels. The use of green marketing should lead to the fulfillment of their overall marketing strategy. Lee argues that any business should use marketing elements that will strengthen its market position. (Lee, 2019, pp. 66-81) Derevianko also agrees with this view, arguing that it is a priority to understand the differences and then combine strategy with elements. (Derevianko, 2019, pp. 511-536) According to Krizanova however, it is necessary to supplement the mentioned strategy with a brand. (Krizanova et. al., 2013, pp. 105 - 112)

It is likely that aspects that could cause the refinery's location could not be expected. Binding of BioVerno. Individual aspects can be divided into three fundamental areas and natural, economic, political and social factors. Natural factors include the inclusion of natural resources such as unrestricted access to raw materials, environmental barriers where excess production and extraction leads to the degradation of the environment; the ability and speed of biodegradability materials. Other aspects that need to be implemented are economic. These can be included cost of production, market size, access to labor force and the volume of demand. The last factors to be taken into account are the political and social aspects to be taken into account legal regulation and impact of the organization (ecological) to location. (Curtin, Gangi, 2016, p.1-9) Based on these aspects, it can be argued that the manufacturing industry is key. Behun et. al., argue that its essential importance is in national economies and it can contribute to the creation of sustainable economic growth. (Behun et. al., 2018, p. 23 – 39)

## **3. CUSTOMER ASPECTS**

### **3.1. Challenges of biofuel producers in the markets**

Search for new technologies of renewable energy sources are a result of the challenges associated with the need to reduction of CO<sub>2</sub> emissions and a reduction of fossil fuel extraction. The energy of biofuels in comparison to other forms renewable energy (photovoltaic, solar collectors, energy wind or tidal) can be used in transport and easily stored. During production of biofuels from agricultural biomass important is the policy of sustainable use of raw materials. Also it should not affect to security of food production system. One of the major problems are compatibility with the legal aspects (both national and international), which are relate to human rights, working conditions and land ownership. The huge challenge is also the socio-economic development of countryside areas.

From the European markets point of view biofuel producers must take into account first of all the EU directive ILUC about fuel quality and renewable energy. The regulation EU on fuel quality and renewable energy, biofuel producers listed the following challenges:

- increasing energy efficiency by 20% since 2020,
- reduction in greenhouse gas emissions by 20% since 2020,
- increasing the share of renewable energy in final energy consumption up to 20%,
- reduce the proportion of energy acquired from biofuels of agricultural origin,
- used in transport to 10% (Directive 2009/30EC of the European Parliament and of the Council, 2009, p. 89 – 96).

Based on assumptions and OECD, production and exclusion can be assumed. According to OECD sources, figure 1 shows a graphical overview of ethanol production and use in each case. According to the picture, the European Union will produce 7% of ethanol by 2025 and others in this financial situation.

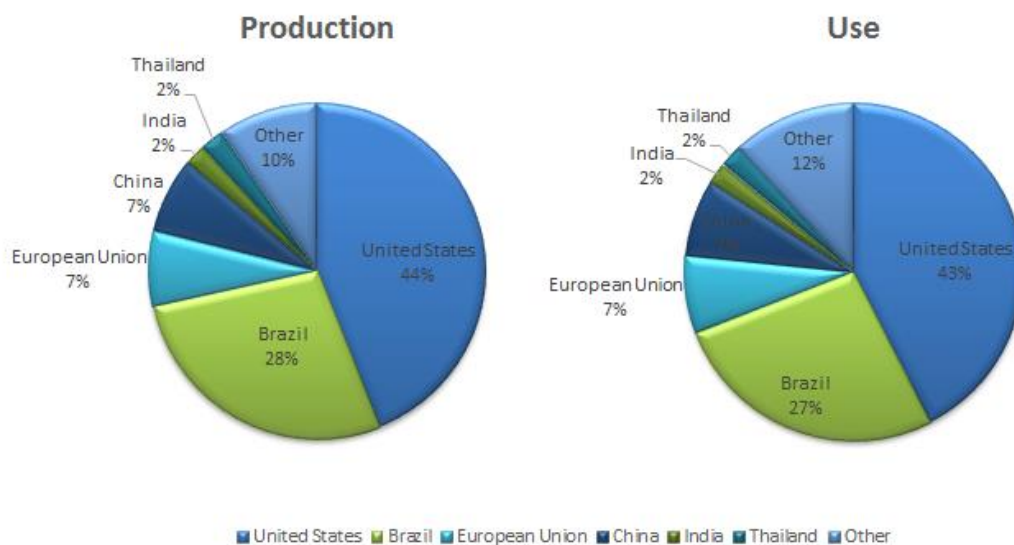

Figure 1. Regional distributions of world ethanol production and use in 2025  
Source: OECD/FAO "OECD-FAO Agricultural Outlook (p. 5)

Biofuels should be good for environment and those are part of sustainable life cycle. However, the production of biofuels, a number of problems, which are the most active producers do not want to see and understand. At worst, biofuel production contributes to climate change than fossil fuels and at the same time causing the loss of biodiversity and the destruction of the world's diverse regions. Tropical rainforests grown on the holding of palm oil has caused and will cause not only a massive becoming endangered biodiversity also significant greenhouse gas emissions. Bioethanol produced product only fields of corn and sugar cane in warm countries. Cultivation of nitrogen fertilizers commonly used. This can lead to large emissions of greenhouse gases (nitrogen dioxide), even larger than if fossile oil would be used. Nitrogen dioxide is a very powerful greenhouse gas. Possible biofuel customer can also be aware of this kind not so welcome aspects and refuses to buy biofuel. (Sustainability of liquid biofuels, 2017, p. 16 - 22)

Kliestikova et. al argue that Europe has been developing strong public support for renewable energy over the last decade. For example, the production of electricity from purpose-built biomass, or production from bio-waste (Kliestikova, et. al, 2018, p. 755-767). Large distribution of the biofuel energy has challenges in existing network infrastructure in EU because of lack of

investing. Ionescu adds that in order to build a quality distribution, it is necessary to examine all aspects that may affect it. (Ionescu, 2019, p. 35 – 41). Lack of biofuel network infrastructure and distribution is EU and local problem. Also price of biofuel shouldn't be much more than normal fossil fuel. Biofuel selection possibility should be prepared already in car factory or used car could be changed to biofuel compatibility with minimum costs. Biomass can also be used to heat and energy, and thus in direct competition with the production of biofuels. This can be also blocking point from biofuel availability point of view. If biofuels are used 100% availability of them must be taken in to account in global and local level. (Air Quality and Biofuels, 2011)

### **3.2. Marketing and distribution plans for home market UPM Bio Berno**

If the company UPM wants to expand to foreign countries with their bio products, first of all she should evaluate economic and political situation in the foreign country. And if the company wants to launch to any EU member states market it is necessary to evaluate the situation in all EU states. Nowadays in European Union increase a demand for energy and biofuels. At the same time, it is necessary to follow and decrease the impact of energy branch to environment. For that reason, the European Committee try to create effective policy of energy Union. The goal of Energy Union is to ensure sustainable, low carbonic and ecological European Economy. The legislation supports of biofuel lead to cut down of greenhouse gas from traffic and to raise the percentage of renewable resources usage. Here can you see that the EU under the Energy Union tries to ensure the effective biofuel and bioenergy policy. The European Committee try to get the Energy Union policy well known in each EU member states during regularly visits where present the situation about bioenergy. This opportunity can use the company UPM, so the firm doesn't have to invest their financial middle to marketing campaign, which should increase the awareness about biofuel and bioenergy. The company can invest to promote the brand BioVerno. In connection with biofuel promotion should the company create a marketing campaign, where can emphasize the meaning of biofuel for people, firm and environment. Next the company can use much kind of Medias like social media, advertising in TV and newspapers and outdoor advertising. On the one hand biodiesel can be distributed by intermediary. The intermediary can be the company which offers fuel to final customer. On the other hand, the firm can use the direct distribution, when the company will construct own petrol station for biofuel in different countries. For the successful promotion in foreign markets and to reach profit, it is necessary to ensure other political and legal aspect in each country. Moreover, it should be better, when the company could secure closely cooperative relationships with automobile producers. The reason is to produce special autos which should be technically adapted to consumption of biofuels. (Green Garage, 2016)

## **4. DISCUSSION**

Based on the data obtained from the analytical part of the article, it is possible to proceed to the discussion part, which aims to define a marketing strategy in relation to the use of aspects of green marketing in the field of bioenergy. At the beginning of the discussion it is necessary to focus on the context of vegetable oil and corn for biofuel production. However, the question is whether the use of scarce fertile land for the cultivation of biomass as a raw material for bioenergy is a problem. Nowadays biofuel is very popular and frequent discussed topic between politicians but also between all people, who on one hand see a lot of advantages of biofuel but on the other hand they critics bio products a lot. Different resources show that biodiesel is more injurious to health by their emissions than the classic diesel. Moreover, biodiesel produces more carbon dioxide or carbon monoxide. Next resources show that for example for the production of one-liter biofuel is needed 2500 liter of water . That can be considered as a very critical disadvantage of biofuel production.



The reason is that in these days comes the situation that sources of groundwater start to run out. Here can you see, that despite of the lack of drinkable water in third World, the production of biofuel still continues. Additionally, biofuel can cause many other negative situations. According to the World bank the establishment of biofuel lead to growing of basic foodstuffs prizes by 75%. The establishment of biofuels in developing countries case many other problems in the Third World. Moreover, it can lead to food crisis . In August 2012 said the board president of Swiss food-procesing company Nestlé, Peter Brabeck, with the reference to last report from OSN Organization for nutrition and agriculture, that the World face before the worse food crisis than in year 2008, because of oversized usage of arable land for production of biofuel. Next critical biofuel disadvantage can you see in the fact, that growing of "energetic crop plant" like a corn or rape include huge emission of nitrous oxide, which is 300x greenhouse gas than CO<sub>2</sub>. According to Crutzen study growing bio products leads to higher production of greenhouse gas by 50 - 70% than from the fossil fuel. Production of biofuels cases a lot of disadvantage, which can be very hard to solve. That is the reason, why it is necessary to look for other alternatives, which should this disadvantage of production minimalism. According to us the production of biofuel should be under detailed development and research. During the research it should be found out same new alternative, how could be made biofuel without 2 500 Liter consumption of water. Next thing we can find out if is possible use various trash form (polluted water, plastic, glass, etc.) for biofuel production. Of course it will be necessary all these materials transform for the usage.

If we want to define the resultant strategy for the Finnish company UPM BioVerno, it is necessary to look at its definition from different perspectives. On the basis of the findings, it can be argued that the company has the prerequisites for competition. Koziuk et. al who argue that environmental regulatory rigor must also be taken into account. (Koziuk, et al., 2019, p. 278-298). On the basis of this, it is possible to proceed with the design of strategies. A strategy using the principles of green marketing would be different for the separate Finnish market. In it, the company uses waste from wood processing to produce biofuel. In Finland this is very successful as all materials, liquids, wastes are known which are produced by cellulose and other wood processes. Based on this, the company has easier access to biofuel processing. Therefore, in this context, we can build marketing strategies on the knowledge and knowledge of employees and customers. These are essential to make it easier to access biofuels and bioenergy. In 2015, the company managed to produce 3,300,000 tons of cellulose. To produce one tonne of cellulose, the company consumes 6 m<sup>3</sup> of pine, which means that 550 000 m<sup>3</sup> of pine is consumed for annual cellulose production. The question, however, is what happens if there is no pulp production in Finland or if there is not enough pine. Will it affect the economic and marketing activities of the company? BioVerno's activities can have a significant impact on the entire business, since without the production of cellulose, BioVerno cannot provide an economically profitable tall oil product to the market. Even the company claims in its annual report that its annual output is sufficient to drive 25,000 km per year, which is acceptable for the 2.6 million passenger cars that travel on Finnish roads. (Annual Report, 2019, pp. 50-68). Even the authors of Popp et. al argue that transport biofuels are currently the fastest growing sectors of bioenergy. (Popp, et. Al, 2018. p. 477-493) The resulting marketing strategy of a company oriented to the Finnish market can be built on knowledge management, which in this case is irreplaceable in this case. The elements of green marketing used by the company are partnership and cooperation with the independent non-profit organization ZERO. In collaboration with the organization, the company aims to promote low-emission biofuels and sustainable bio-products to the public, which significantly reduce greenhouse gas emissions compared to fossil fuels and products. Thus, they contribute to improving the environment on a global scale. In this way, the company also provides joint support for low emission sustainable

development in the transport and petrochemicals sectors on the European market. Mala and Bencikova, who consider this fact in the field of green marketing to be an essential factor in the development of the company's marketing strategy, also share this view. (Mala, Bencikova, 2018, pp. 64-74). Based on the above, it can be argued that the general marketing strategy on which a company builds its brand is based not only on the principles of knowledge management, but also on the principles of entering into partnerships. (Nadanyiova, 2013, p. 87 - 92) This can be used to more effectively promote the elements of green marketing to the public, build competitiveness in the market environment and strengthen the brand with respect to the European market. The author Vafaei also agrees with this opinion. (Vafaei, Azmoon, Maria, 2019, p. 475-491) By producing products that are made from renewable and recyclable materials, an innovative activity that is focused on six basic business areas can be part of the company's marketing strategy: UPM Biorefining, UPM Energy, UPM Raflatac, UPM Special Papers, UPM Paper ENA and UPM Plywoo. (Press release UPM BioVerno, 2018)

The perception of marketing strategy in connection with the application of the element of green marketing is currently of major importance. Each company has to adapt to market conditions and requirements in a different way, and in this context it must also intensively support the environment by using various marketing tools. In this way, the company can also respect the needs of customers and build their loyalty. Gajanova et. al. (Gajanova, Nadanyiova, Moravcikova, 2019, pp. 65-84). Similar opinion is expressed by Majerova, who claims that brand policy plays an important role in achieving business goals. (Majerova, 2014, pp. 3-8)

## 5. CONCLUSION

BioVerno is very nice product but it can use only in case of massive ccellulose production is near. There should be another diesel biofuel selection also available in order to serve all of the diesel cars in Finland. And there is already but not so massive ones. e.g Neste NEXBTL. The rest of the countries have to select another kind of biodiesel or biofuel solution. Because 100% BioVerno cannot serve all of the diesel cars in Finland it is not for massive export. Large distribution of the biofuel energy has challenges in existing network infrastructure in EU because of lack of investing. Some of the EU countries still struggling with financial problems. This might slow down promoting of biofuels generally. By gathering all the data in the analytical and discussion sections, it can be argued that UPM BioVerno provides sustainable and secure solutions for the global marketplace, trying to make the market environment attractive to its customers with its specific products.

Therefore, when developing and implementing a marketing strategy, it is necessary to constantly take into account the environmental impact and to make effective use of the various elements of green marketing. Moravcikova et. al argues that at present there is no comprehensive model for implementing organic marketing with a link to the company's marketing strategy. (Moravcikova, et. Al, 2017, p. 25–31) Unlike Moravcikova, Nadanyiova claims that green marketing is a substantial part of the entire marketing performance of a business (Nadanyiova, Kicova, Rypakova, 2015, p. 219-226). On the basis of the above, it can be argued that a model should be devised to properly implement the elements of green marketing into the marketing strategy of the company.

**ACKNOWLEDGEMENT:** *This paper is an output of scientific project VEGA no. 1/0718/18: The impact of psychographic aspects of pricing on the marketing strategy of companies across products and markets.*

**LITERATURE:**

1. Air Quality and Biofuels. Retrieved 01.4.2020 from <https://www.intechopen.com/books/environmental-impact-of-biofuels/air-quality-and-biofuels>
2. Annual report of UPM BioVerno. UPMBIOFORE. Retrieved 31.03.2020 from <https://www.upm.com/siteassets/asset/investors/2019/upm-annual-report-2019.pdf>
3. Curtin, S, Gangi, J. (2016). Fuel Cell Technologies Market Report. *Fuel Cell and Hydrogen Energy Association, Washington, D.C.*
4. Behun, M, Gavurova, B, Tkacova, A, Kotaskova, A. (2018). The Impact of the Manufacturing Industry in the Economic Cycle of European Union Countries. *Journal of Competitiveness*, vol. 10, no. 1, pp. 23 – 39.
5. Derevianko, O. (2019). Reputation stability vs anti-crisis sustainability: under what circumstances will innovations, media activities and CSR be in higher demand?. *Oeconomia Copernicana*, vol. 10, no. 3, pp. 511 – 536.
6. Directive 2009/30EC of the European Parliament and of the Council amending Directive 98/70/EC as regards the specification of petrol, diesel and gas-oil. Retrieved 31.03.2020 from <https://eur-lex.europa.eu/legal-content/EN/TXT/?uri=celex%3A32009L0030>
7. Gajanova, L, Nadanyiova, M, Moravcikova, D. (2019). The use of demographic and psychographic segmentation to creating marketing strategy of brand loyalty. *Scientific Annals of Economics and Business*, vol. 66, no. 1, pp. 65 – 84.
8. Ionescu, L. (2019). Towards a Sustainable and Inclusive Low-Carbon Economy: Why Carbon Taxes, and Not Schemes of Emission Trading, Are a Cost-Effective Economic Instrument to Curb Greenhouse Gas Emissions. *Journal of Self-Governance and Management Economics*, vol. 7, no. 4, pp. 35-41.
9. Kliestikova, J, Krizanova, A, Corejova, T, Kral, P, Spuchlakova, E. (2018). Subsidies to Increase Remote Pollution?. *Science and Engineering Ethics*, vol. 24, no. 2, pp. 755-767.
10. Koziuk, V, Hayda, Y, Dluhopolskyi, O, Klapkiv, Y. (2019). Stringency of environmental regulations vs. global competitiveness: Empirical analysis. *Economics and Sociology*, vol. 12, no. 4.
11. Krizanova, A, Majerova, J, Kliestik, T, Majercak, P. (2013). Theoretical Aspects of Brand Building in Seafood Industry. *NAŠE MORE*, vol. 60, no. 5-6, pp. 105 – 112.
12. Lee, N. (2019). R&D accounting treatment, firm performance, and market value: Biotech firms case study. *Journal of International Studies*, vol. 12, no. 2.
13. Nadanyiova, M, Kicova, E, Rypakova M. (2015). Green marketing and its exploitation in Slovak companies, Conference: 4th World Conference on Business, Economics and Management (WCBEM) Location: Ephesus, TURKEY. *Procedia Economics and Finance*, vol. 26.
14. Nadanyiova, M. (2013). Possibility of Introducing the CRM System in Railway Company Cargo Slovakia, 7th International Conference on Transport Means Location: Kaunas Univ Technol, Kaunas, LITHUANIA. *Transport Means - Proceedings of the International Conference*.
15. Majerova, J. (2014). Comprehensive Proposal of Activities of Product Brand Policy in Conditions Specific to Slovak Republic, 2nd International Conference on Economics and Social Science (ICISS) Location: Shenzhen, PEOPLES R CHINA. *Advances in Education Research*, vol. 61.
16. Mala, D, Bencikova, D. (2018). Innovations of a green product. *Ekonomicko-manazerske spektrum*, vol. 12, no. 1, pp. 64 – 74.
17. Moravcikova, D, Krizanova, A, Kliestikova, A, Rypakova, M. (2017). Green Marketing as the Source of the Competitive Advantage of the Business. *Sustainability*, vol. 9, no. 12.

18. OECD/FAO “OECD-FAO Agricultural Outlook”, OECD Agriculture statistics (database), Retrieved 18.04.2020 from <http://dx.doi.org/10.1787/agr-outl-data-en>
19. Popp, J, Kot, S, Lakner, Z, Olah, J. (2018). Biofuel use: peculiarities and implications. *Journal of Security and Sustainability Issues*, vol. 7, no. 3, pp. 477 – 493.
20. Press Release UPM BioVerno. UPM Biofuels and ZERO environmental organisation cooperate to promote green shift in transportation and petrochemical industry. Retrieved 10.04.2020 from <https://www.upmbiofuels.com/whats-new/news/2018/01/upm-biofuels-and-zero-environmental-organisation-cooperate-to-promote-green-shift-in-transportation-and-petrochemical-industry/>
21. Sustainability of liquid biofuels. Retrieved 01.04.2020 from <https://www.raeng.org.uk/publications/reports/biofuels>
22. Ten Biggest Pros and Cons of Biofuels. Retrieved 02.04.2020 from <https://greengarageblog.org/10-biggest-pros-and-cons-of-biofuels>
23. Vafaei, S, A, Azmoon, I, Maria, F. (2019) The Impact of Perceived Sustainable Marketing Policies on Green Customer Satisfaction. *Polish Journal of Management Studies*, vol. 19, no. 1, pp. 475 – 491.

## **DOES THE INSTITUTIONAL ENVIRONMENT AFFECT PERFORMANCE? EVIDENCES FROM DIFERENT COUNTRIES**

**Liliane Cristina Segura**

*Universidade Presbiteriana Mackenzie, Brazil  
liliane.segura@mackenzie.br*

**Vladimir Fernandes Maciel**

*Universidade Presbiteriana Mackenzie, Brazil  
vladimir.maciel@mackenzie.br*

**Henrique Formigoni**

*Universidade Presbiteriana Mackenzie, Brazil  
henrique.formigoni@mackenzie.br*

**Julian Alexienco Portillo**

*Universidade Presbiteriana Mackenzie, Brazil  
julian.portillo@mackenzista.com.br*

**Daniella Guimaraes Bergamini de Sa**

*Universidade Presbiteriana Mackenzie, Brazil  
daniella.sa@mackenzie.br*

### **ABSTRACT**

*In the global scenario, companies from different countries need to understand the influence of the economic environment in order to make their strategic planning. Sometimes is difficult to be compliant with all the regulations and this could be the highest risk these companies will face when they are stablished globally. In the empirical researches, we have found some evidences that economic freedom is related to economic growth and it affects the productive effort and the efficient use of resources (for example, property rights affects the economic growth and economic freedom promotes the financial development). Considering these evidences, our purpose is to investigate if the level of regulation affects companies' performance in 12 different countries. Data were collected from the Capital IQ and Fraser Institute databases. A panel of data of 10 years of observations were used with the Stata software. The general results show that the less free environment, the company's performance worsens while its leverage increases and the higher the regulation, the worse the company's performance (considering its indebtedness level). Based on them, the paper intends to open the discussion about the level of government regulation pointing out the benefits to companies' decisions from a less regulated business environment.*

**Keywords:** *Economic Growth, Institutional Environment*

### **1. INTRODUCTION**

In the global scenario, companies need to develop strategies in the way they may improve their financial performance considering the influence of the economic environment. Macroeconomic variables tend to affect business and some studies presented significant relation with financial performance of the company (Asbridge, Walters, & Jones, 1994).

But institutional variables are as important as macroeconomic variables. North (1991, p.97) defines institutions as

(...) the humanly devised constraints that structure political, economic and social interaction. They consist of both informal constraints (sanctions, taboos, customs, traditions, and codes of conduct), and formal rules (constitutions, laws, property rights).

As argued by North (1990), some economies develop institutions that produce growth and development, while others develop institutions that produce stagnation. Consequently, companies find difficulties to be compliant with all the regulations imposed by the government and this could be the higher risk these companies will face when they are established globally. Gwartney & Lawson (2003) explain that the essence of economic freedom means personal choice, voluntary exchange, freedom to compete and protection of person and property. The authors also state that the level of a country's economic freedom is determined by its institutional settings and its economic policy. In the economic theory, we have some evidences that economic freedom is related to economic growth (Bjørnskov, 2016; Mahmood; & Azild, 2011; Vega-Gordillo & Alvarez-Arce, 2003), effects the productive effort and the efficient use of resources (Gohmann, Hobbs, Gulf, Myers, & Mccrickard, 2006). More specifically, property rights affects the economic growth and freedom promotes the financial development (Bjørnskov, 2016). In this sense, the purpose of this paper is to investigate if company's financial performance is affected by the country's level of economic freedom. As a contribution, we intent to open a discussion about government regulation on business, labor and credit markets and how its interfering may cause on the performance of the companies in general. Evidences from our observation may be the best way to call the attention from companies and governments about how regulations on business environment affects financial performance. This paper is divided into three sections – besides introduction and final remarks. The first section shows the theoretical support. The second section describes the research methodology and empirical procedures. The third analyzes the results and discusses the findings.

## **2. THEORETICAL SUPPORT**

### **2.1. Performance in companies around the world**

Company's performance is affected by the economic environment and by the market context such as rivalry - besides their strategy (Baron, 2012). In this sense, Orlitzky, Schmidt, Rynes, & Rynes (2003) states that the economic environment is still more important that the strategy they are following, once this environment is not controlled by companies. An research done by Asbridge et al. (1994), identified that macroeconomic variables affects bank performance in commercial banks. In this study, exchange rate, interest rate, external debt, import, exports and money supply was independent variables while financial performance was the dependent variable. This study found that exchange rate, external debt and gross domestic product have influence on the financial performance of banks. They also found that exchange rate and gross domestic product have positive and significant impact on the financial performance and external public debt has negative and significant influence on the financial performance. Financial performance also may be affected by internal factors as governance, debt, size, sustainable practices and cash flow as pointed out by many authors (Anderson & Reeb, 2004; Dami, Rogers, & Ribeiro, 2007; Gallego-Álvarez, Segura, & Martínez-Ferrero, 2015; Santos, Murmura, & Bravi, 2018). An study conducted by Carton & Hofer (2010) addresses the measurement of organization financial performance and has undertaken to empirically identify both the different distinct dimensions of organizational financial performance and the measures that represent those dimensions. Their study showed that some variables affects financial performance are growth, economic value, cash flow, market, cost of capital, leverage and change survival.

We may understand that financial performance is affected by company's financial strategy, however, environmental variables are too important to the company's performance as well as the internal variables.

## **2.2. Regulation and Economic Freedom**

Regulation is one of the five dimensions of Fraser's Economic Freedom of the World Index (EFW from now on). According to Gwartney & Lawson (2003, p. 415) "when regulations restrict entry into markets and interfere with the freedom to engage in voluntary exchange, they reduce economic freedom". Regulatory restraints that imposes restrictions on business, labor and credit markets are measured by EFW. As well documented by the empirical literature, there are significant statistically relationship about firms (or countries) performance and economic freedom. Gwartney (2009) based on the institutional theory of growth found cross-country comparisons of different economic performances related to different economic freedom levels. Countries with higher level of economic freedom have better economic performance. McMullen *et al.* (2008) pointed out that economic freedom restrictions impact entrepreneurial activity differently. It depends on the particular dimension restricted by and the entrepreneur's motive for engaging in entrepreneurial activities. Bengoa & Sanchez-Robles (2003) conducted a research that found economic freedom has a positive relationship with foreign direct investments. However, they also comment that their research found that the host country requires adequate human capital, economic stability and liberalized markets to benefit from long-term capital flows. Bjørnskov (2016) explored the politically contested association between the degree of capitalism, by capturing and measuring economic freedom, and the risk and characteristics of economic crises. He also offered some theoretical considerations, estimate the effects of economic freedom on crisis risk in the post-Cold War period 1993–2010. He used the duration, peak-to-trough GDP ratios and recovery times of 212 crises across 175 countries within this period. The results showed that economic freedom is robustly associated with smaller peak-to-trough ratios and shorter recovery time. These effects are driven by regulatory components of the economic freedom index. Gohmann *et al.* (2006) discuss that the main focus of traditional economists uses compare competitive markets frameworks in innovation, discovery and arbitrage as forms of entrepreneurship. What we have to remember is that unproductive and destructive entrepreneurship as lobbying for subsidies, barriers to entry, special tax treatment, and price regulation are most used in regulated countries as a way to create barriers to the other competitors.

## **2.3. Previous studies**

As previous studies, Sufian & Habibullah (2010) found that economic freedom and business freedom shows positive impacts, implying that higher freedom on the activities that banks can undertake and entrepreneurs to start businesses increases banks' profitability. This study provides empirical evidence on the impact of economic freedom on banks' performance. The analysis was made on Malaysian banking sector during the period of 1999–2007. These findings suggest that the unproductive and destructive entrepreneurship may have a corrosive impact on Malaysian banks' profitability. However, the same study found that the impact of monetary freedom is negative, demonstrating the importance of government intervention in determining the profitability of banks operating in the Malaysian banking sector (Sufian & Habibullah, 2010). Chortareas, Girardone, & Ventouri (2013) investigated the dynamics between the financial freedom counterparts of the economic freedom index drawn from the Heritage Foundation database and bank efficiency levels. They founded that the influence from financial freedom in bank performance tend to be better seen in free markets with higher quality of governance. However, in insurance firms, Lee & Lin (2016) showed that financial liberalization has a negative impact in the financial performance.

Not only internal factors were observed in private ownership company's performance. Berg, Lin, & Tsaplin (2005) showed that regulatory incentives reward behavior that affects profits and costs. Privately owned firms respond to these incentives increasing cash-flow and mark-up, increasing performance and value to the shareholder. Many authors also found that less investment protector (less regulation) also influence company's corporate governance. Yoshikawa & Rasheed (2010) and Firth, Fung, & Rui (2006) also indicates that countries with inadequate investor protection laws and weak law enforcement have poor corporate governance. We also found that Peev (2015) used a dataset matching firm-level with country indicators to access to external finance, governance and economic liberalization and it shows that they have direct effect on firm growth. However, they also indicate that the better performance is observed in countries with better governance indicators.

### 3. RESEARCH METODOLOGY

This research used a hypothetical-deductive research, according to the proposed grounds for Popper (2005) and it is characterized by the establishment of hypotheses to be tested through empirical research, namely, the observation of reality. The data used for hypothesis testing was econometric analysis using multiple regressions (Hair *et al.*, 2010; Greene, 2003). It has investigated a causal relationship between variables, so it is a correlational research.

#### 3.1. Population and Sample Selection

In order to carry out this study, we have selected companies from 13 different countries from 5 continents worldwide. We used 10 largest companies based on Equity and a 10 years panel data from 2007 to 2017. The data were obtained from Capital IQ database and from Fraser Institute, and they were combined to produce this study. Moreover, 2016 was the most recent year for which complete the Economic Freedom Index (EFI). Additionally, the data comprise with the database from Fraser Institute during the period from 2007–2017. From Capital IQ we collected the annual report and all information from each of the company. Due to limitations on the disclosure process of companies, many of them did not have data for all the years observed, so it was necessary for the authors to have an unbalanced panel. On the debugging process were excluded those without accounting data needed and, also financial companies, for its peculiar characteristic of performance to the research. The sample of research is 130 companies, with a total of 1170 observations.

#### 3.2. Hypothesis

The hypothesis is based on the literature - we have some evidences that economic freedom is related to economic growth (Bjørnskov, 2016; Mahmood; & Azild, 2011; Vega-Gordillo & Alvarez-Arce, 2003) and affects the productive effort and the efficient use of resources (Gohmann *et al.*, 2006), while property rights affects the economic growth and economic freedom in general promotes the financial development (Bjørnskov, 2016). In the other hand, we understand that performance is managed by internal variables as size, leverage, retained earnings, Ebitda (Anderson & Reeb, 2004; Dami *et al.*, 2007; Gallego-Álvarez *et al.*, 2015; Santos *et al.*, 2018) and external variables (Asbridge *et al.*, 1994; Baron, 2012; Carton & Hofer, 2010; Orlitzky *et al.*, 2003). Based on these researches, it was possible to draw the following hypothesis:

*H1: There is a relation between performance of the company and the country's regulation score.*

In order to test this hypothesis, we estimate an econometric model defined below.



### 3.3. Definitions of the Model and Variables

The model used in this research has been drawn from researches on corporate financial performance, such as: Anderson & Reeb (2004); Dami et al., (2007); Gallego-Álvarez et al. (2015); Santos et al. (2018), Asbridge et al. (1994); Baron (2012); Carton & Hofer (2010); Orlitzky et al. (2003) were the basis to seek the necessary variables, since they are works developed with companies all around the world.

#### 3.3.1. Econometric Model

The model 1 allows to evaluate the research hypothesis relating the economic freedom level and according to equation 1 that detailed Performance is the company's *Perform* as dependent variable;  $EFW_{it}$  is the level of Economic Freedom of the country this company is located as independent variable and  $VC_{jit}$  are the control variables and  $\varepsilon_{it}$  is the error.

$$Perform_{it} = \beta_0 + \beta_1 EFW_{it} + \sum_{j=1}^k \delta_j VC_{jit} + \varepsilon_{it}$$

The model 2 allows to evaluate the research hypothesis relating the economic freedom level and according to equation 2 that detailed performance is the company's *ROA* as dependent variable;  $EFW_{it}$  is the level of Economic Freedom of the country this company is located as independent variable and  $VC_{jit}$  are the control variables and  $\varepsilon_{it}$  is the error.

$$ROA_{it} = \beta_0 + \beta_1 EFW_{it} + \sum_{j=1}^k \delta_j VC_{jit} + \varepsilon_{it}$$

The model 3 allows to evaluate the research hypothesis relating the economic freedom level and according to equation 1 that detailed Performance is the company's *ROE* as dependent variable;  $EFW_{it}$  is the level of Economic Freedom of the country this company is located as independent variable and  $VC_{jit}$  are the control variables and  $\varepsilon_{it}$  is the error.

$$ROE_{it} = \beta_0 + \beta_1 EFW_{it} + \sum_{j=1}^k \delta_j VC_{jit} + \varepsilon_{it}$$

#### 3.3.2. Dependent Variable

The dependent variables for our analysis were used the following proxies: Earnings before interest, taxes, depreciation and amortization (Ebitda) representing the cash generation from the companies, divided by total assets, return on equity (ROE) for financial performance, and return on assets (ROA) for operating performance. All the information obtainable for constructing these variables was selected up to 2017, the last year for which economic-financial data were available for the different firms comprising the sample. These variables were obtained from the annual reports presented by each company on Capital IQ database. For the Ebitda Variable we calculated the ratio between Ebitda and total assets, producing the variable EBITDA used in this research, ROE variable we calculated the ratio between net income and stockholders' equity and for the ROA variable we calculated the ratio between operating income and total assets. Multiple regression analysis was used to test the hypotheses. Separate models were run for EBITDA, ROE and ROA as dependent variables.

#### 3.3.3. Independent Variables

The index published by The Fraser Institute, the Economic Freedom Index of the World (EFW) is regularly published and updated since 2000. It is composed by a set of measures, based on 42 data points were used to build 5 major areas, but many of those components are themselves made up of several sub-components. The cornerstones of economic freedom are personal choice, voluntary exchange, freedom to enter markets and compete, and security of the person

and privately-owned property (Gwartney, Lawson, Hall, & Murphy, 2018). The EFW is composed by 5 areas as described:

- **Area 1: Size of Government:** As government spending, taxation, and the size of government-controlled enterprises increase, government decision-making is substituted for individual choice and economic freedom is reduced (Gwartney et al., 2018).
- **Area 2: Legal System and Property Rights:** Protection of persons and their rightfully acquired property is a central element of both economic freedom and civil society. Indeed, it is the most important function of government (Gwartney et al., 2018).
- **Area 3: Sound Money:** Inflation erodes the value of rightfully earned wages and savings. Sound money is thus essential to protect property rights. When inflation is not only high but also volatile, it becomes difficult for individuals to plan for the future and thus use economic freedom effectively (Gwartney et al., 2018).
- **Area 4: Freedom to Trade Internationally:** Freedom to exchange—in its broadest sense, buying, selling, making contracts, and so on — is essential to economic freedom, which is reduced when freedom to exchange does not include businesses and individuals in other nations (Gwartney et al., 2018).
- **Area 5: Regulation:** Governments not only use a number of tools to limit the right to exchange internationally, they may also develop onerous regulations that limit the right to exchange, gain credit, hire or work for whom you wish, or freely operate your business (Gwartney et al., 2018).

In addition to the independent variable proposed, in this study we have included total debt, company size, retained earnings, sector, year and country as control variables. These variables have been used in previous studies related to emissions. For example, leverage as the debt to equity ratio or debt to firm assets ratio has been used by authors such as Chui, Lloyd, & Kwok (2002); Gallego-Álvarez & Segura (2015); Gallego-Álvarez, Segura, & Martínez-Ferrero (2015); Segura, Formigoni, David, & Abreu (2016). The research papers informed that leverage is more likely to influence ROE rather than ROA and they included leverage in their research. With respect to size, Dami, Rogers, & Ribeiro (2007), Anderson & Reeb (2004) and Lee & Lin (2016) initially included this variable among the control variables. In terms of retained earnings, Amidu (2016) shows that as much as the company retain earnings, higher is the performance.

#### 3.3.4. Control Variables

**Leverage** [ $ET_{(i,t)}$ ] as the total debt of company. Knowing as follows in equation 1 that PC is the current liabilities of company  $i$  in year  $t$ ; PNC is the non-current liabilities of company  $i$  in year  $t$ ; and AT is the total assets of company  $i$  in year  $t$ .

$$ET_{i,t} = \frac{PC_{i,t} + PNC_{i,t}}{AT_{i,t}}$$

**Company size** [ $LNAT_{(i,t)}$ ] is used by (Minichilli, Corbetta, & MacMillan, 2010) (Soares & Kloeckner, 2008) Minichilini *et al.* (2010), Perobelli & Fama, 2002, Perobelli *et al.* (2005), Soares & Kloeckner (2008) and Zaha (2010), knowing that the larger the size of the company, induce higher level of debt. So, it is measured by the natural logarithm of the total assets of company.

**Retained earnings** is used in the paper of Amidu (2007), and concludes that as higher is the retained earnings, higher is the performance of the company, because its used for investment.

**Year** is identified by dummies to capture any macroeconomic shocks and possible temporal effects that can affect all companies (Barros, 2005). The year dummies are represented by a binary variable and  $t$  is equal to one in the year observed for company  $i$  and zero otherwise.

## 4. DATA ANALYSIS AND RESULTS

### 4.1. Descriptive Analysis

The top 10 companies from the following countries were surveyed: Argentina, Australia, Brazil, China, Colombia, France, Great Britain, New Zealand, Peru, South Africa, Spain, Turkey and the United States. The countries were chosen by the availability of existing data. The Economic Freedom index of each country, according to the Fraser Institute Economic Freedom of the World is showed in Figure 1.

Figure 1 – World Economic Freedom Index

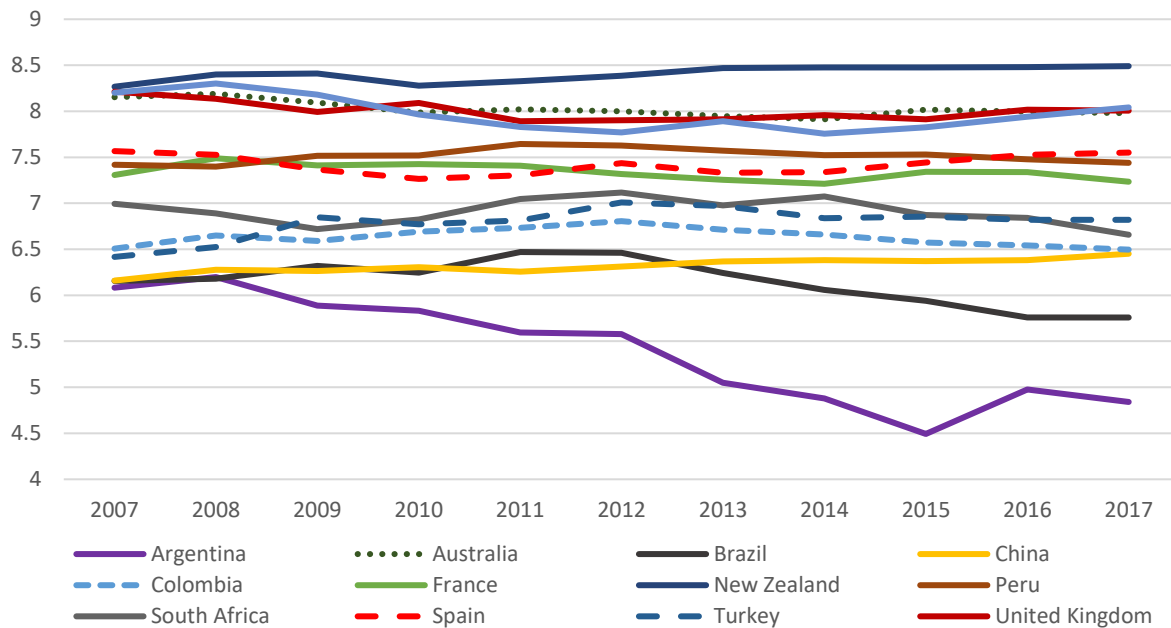

Source: Fraser Institute

We may observe that from the countries researched, we have rank from 4,83 (Argentina, the least free) to 8,49 (New Zealand, the freest). It should be noted that all continents were contemplated, just as the range of Economic Freedom was also. In relation to Area 5, defined as *Regulation*, the behavior of the countries is evidenced in Figure 2.

Figure following on the next page

Figure 2 – World Economic Freedom Index: Area 5 (Regulation)

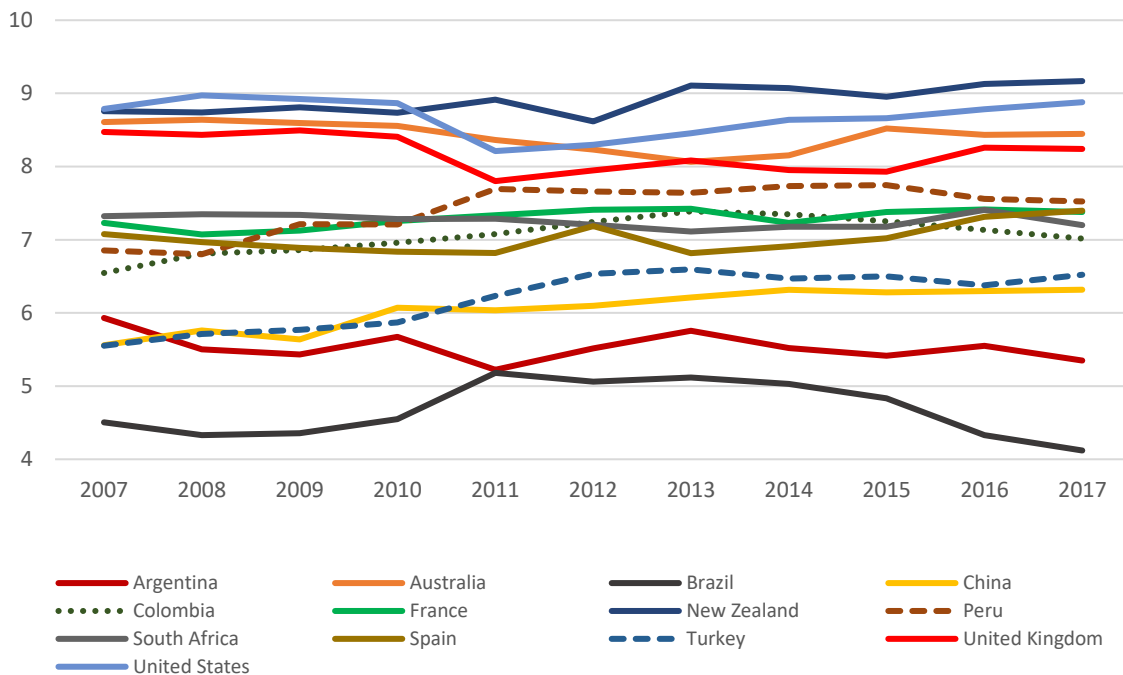

Source: Fraser Institute

It is possible to identify that there is a large and greater range difference between countries regarding the indicator of regulation of each of the countries observed. The average of the observed indicators was also calculated: Ebitda (EOA), Return on Assets (ROA) and Return on Equity (ROE). Table 2 the descriptive statistics of each of the indicators. It can be observed that the average Ebitda return was 37%, the ROA had 17% return and the ROE presented 33% return, on average. It is possible to identify that there is a large and greater range difference between countries about the indicator of regulation of each of the countries observed. The average of the observed indicators was also calculated: Ebitda (EOA), Return on Assets (ROA) and Return on Equity (ROE). Table 1 shows the descriptive statistics of each of the indicators. It can be observed that the average Ebitda return was 37%, the ROA had 17% return and the ROE presented 33% return, on average.

Table 1 – Descriptive statistics

Variable	Obs	Mean	Std. Dev.	Min	Max
EOA	1170	0.37	5.73	-0.15	157.66
ROA	1401	0.17	2.69	-0.34	74.31
ROE	1405	0.33	5.77	-6.96	211.68

Source: IQ Capital

#### 4.2. Regression (GLS) with dummies

Simple regressions were also made with the variables observed and considering the year and country dummies. In this regression, it was not possible to find a significant relationship between the study variables. The variables presented multicollinearity, and for better observation, we opted for panel regression.

### 4.3. Panel Regression

For the panel regression to be performed, the Hausman test was used so that we could decide for the best panel between random effects and fixed effects. The Hausman test indicates that the best model is fixed effects, which was used in this research. The first panel, presented in Table 2, indicates the relationship between the performance of companies and the EFW.

*Table 2 – Financial performance measures and EFW*

	<b>EOA</b>	<b>ROA</b>	<b>ROE</b>
Constant	2.3292	2.2833*	-4.4331
	-1.52	-1.38	-5.55
Economic Freedom Score (EFW)	0.0369	-0.0025	0.4242
	-0.04	-0.03	-0.38
Leverage (ET)	0.6597***	0.2144***	0.0034
	-0.02	-0.02	0.00
Economic Freedom*Leverage (EFW*ET)	-0.0670***	-0.0183***	-0.0002
	0.00	0.00	0.00
LN Total Assets (LNAT)	-0.2858*	-0.2380*	0.1826
	-0.15	-0.13	-0.32
Retained Earnings	0	0	-0.0006
	0.00	0.00	0.00
AIC	456.49	245.30	8764.62
BIC	481.81	271.53	8790.85
N	1170	1401	1401

\* p<0.10, \*\* p<0.05, \*\*\* p<0.01

Source: authors

It is possible to observe that there is no significant relationship between EFW and performance indices alone. However, when we interact the EFW variable with the company's leverage (ET), Ebitda and ROA have a negative and significant relationship.

### 4.4. Regulation Score

The panel regression with fixed effects for the Regulation dimension was performed. The regulatory dimension considers that Governments not only use a number of tools to limit the right to exchange internationally, they may also develop onerous regulations that limit the right to exchange, gain credit, hire or work for whom you wish, or freely operate your business (Gwartney et al., 2018). Considering these statements, the interaction between regulation and leverage was made, testing to measure whether performance is influenced by regulation and, once influenced, whether the company's leverage influences this relationship (see Table 3).

*Table following on the next page*

Table 3 - Financial performance measures and regulation

	EOA	ROA	ROE
Constant	0.5253 -0.37	1.1471* -0.60	-2.2073 -5.12
Regulation Score	0.1152* -0.07	0.1284 -0.08	0.1826 -0.41
Leverage (ET)	0.6096*** -0.01	0.2124*** -0.02	0.0035 -0.01
Regulation*Leverage	-0.0587*** 0.00	-0.0175*** 0.00	-0.0003 0.00
LN Total Assets (LNAT)	-0.1515* -0.09	-0.2170* -0.12	0.1304 -0.24
Retained Earnings	0 0.00	0 0.00	-0.0007 0.00
AIC	-912.92	-194.07	8764.85
BIC	-887.60	-167.85	8791.08
N	1170	1401	1401

\* p<0.10, \*\* p<0.05, \*\*\* p<0.01

Source: authors

In this regression it is possible to observe that the regulation is related to Ebitda, that is, the company's cash generation is positively affected by greater economic freedom in the country. This means that the higher the regulation, the worse the company's performance, considering its indebtedness.

## 5. FINAL REMARKS

This paper aimed to call attention about companies and government about the effects of freedom and regulation on business environment and financial performance. The general results show that the less free environment, the company's performance worsens while its leverage increases and the higher the regulation, the worse the company's performance (considering its indebtedness level). They show that in less free environments, the company's performance worsens when its leverage increases (see Figure 3).

Figure 3 – Scheme: regulation, leverage and performance

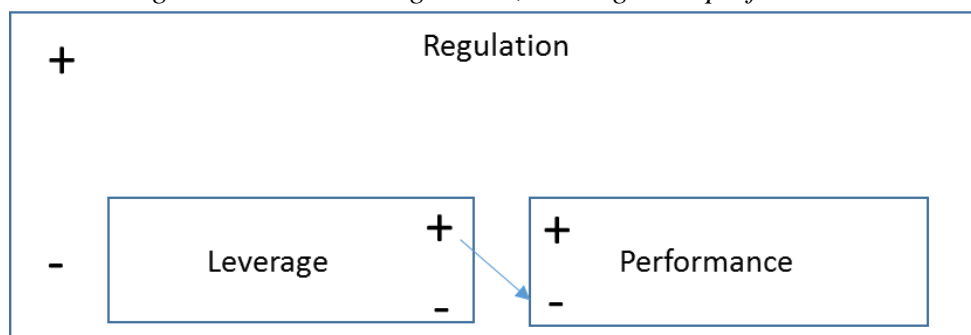

Source: authors

While the summary index EFW does not have significant effects on the company's leverage (ET), Ebitda and ROA, the Regulation (Area 5) affects Ebitda. These results seem to be compatible with the general conclusion of McMullen et al. (2008) that particular economic freedom restrictions impact entrepreneurial activity differently depending on the entrepreneur's motive for engaging in entrepreneurial activities.

In this paper we found that particular economic freedom restrictions affect different financial decisions and performance measures – such as leverage and earnings.

#### LITERATURE:

1. Amidu, M. (2016). How does dividend policy affect performance of the firm on Ghana Stock exchange? *Investment Management and Financial Innovations*, 4(2), 103–111.
2. Anderson, R., & Reeb, D. M. (2004). Board composition: balancing family influence in S&P 500 firms. *Administrative Science Quarterly*, 49(2), 209–237. <https://doi.org/10.2307/4131472>.
3. Asbridge, A. H., Walters, G. V., & Jones, T. R. (1994). Impact of Macroeconomic Variables on Financial Performance of Banks: A Case of Selected Private Commercial Banks in Ethiopia. *Denmark: Concrete Accross Borders*, 7(4), 547–557.
4. Baron, D. P. (2012). *Business and its Environment* (7th ed.). New York: Pearson Education.
5. Bengoa, M., & Sanchez-Robles, B. (2003). Foreign direct investment, economic freedom and growth: new evidence from Latin America. *European Journal of Political Economy*, 19(3), 529–545. [https://doi.org/10.1016/S0176-2680\(03\)00011-9](https://doi.org/10.1016/S0176-2680(03)00011-9).
6. Berg, S., Lin, C., & Tsaplin, V. (2005). Regulation of state-owned and privatized utilities: Ukraine electricity distribution company performance. *Journal of Regulatory Economics*, 28(3), 259–287. <https://doi.org/10.1007/s11149-005-3957-z>.
7. Bjørnskov, C. (2016). Economic freedom and economic crises. *European Journal of Political Economy*, 45, 11–23. <https://doi.org/10.1016/j.ejpoleco.2016.08.003>.
8. Carton, R. B., & Hofer, C. W. (2010). Organizational Financial Performance: Identifying and Testing Multiple Dimensions. *Academy of Entrepreneurship Journal*, 16(1), 1–23.
9. Chortareas, G. E., Girardone, C., & Ventouri, A. (2013). Financial freedom and bank efficiency: Evidence from the European Union. *Journal of Banking & Finance*, 37(4), 1223–1231. <https://doi.org/10.1016/j.jbankfin.2012.11.015>.
10. Chui, A. C. W., Lloyd, A. E., & Kwok, C. C. Y. (2002). The Determination of Capital Structure: Is National Culture a Missing Piece to the Puzzle? *Journal of International Business Studies*, 33(1), 99–127. <https://doi.org/10.1057/palgrave.jibs.8491007>.
11. Dami, A. B. T., Rogers, P., & Ribeiro, K. C. de S. (2007). Estrutura de Propriedade no Brasil: Evidências Empíricas no Grau de Concentração Acionária. *Contextus*, 5(2), 1–10. Retrieved from <http://www.periodicos.ufc.br/index.php/contextus/article/view/602>.
12. Firth, M., Fung, P. M. Y., & Rui, O. M. (2006). Firm Performance, Governance Structure, and Top Management Turnover in a Transitional Economy. *Journal of Management Studies*, 43(6), 1289–1330. <https://doi.org/10.1111/j.1467-6486.2006.00621.x>.
13. Gallego-Álvarez, I., & Segura, L. C. (2015). Greenhouse gas emissions variation and corporate performance in international companies. *International Journal of Global Warming*, 8(4). <https://doi.org/10.1504/IJGW.2015.073055>.
14. Gallego-Álvarez, I., Segura, L., & Martínez-Ferrero, J. (2015). Carbon emission reduction: The impact on the financial and operational performance of international companies. *Journal of Cleaner Production*, 103. <https://doi.org/10.1016/j.jclepro.2014.08.047>.
15. Gohmann, S. F., Hobbs, B. K., Gulf, F., Myers, F., & Mccrickard, M. J. (2006). Economic freedom, entrepreneurial activity, and the service sector. *Journal of Entrepreneurship and Public Policy*, 2(2), 144–159. <https://doi.org/10.1108/JEPP-Mar-2012-0015>.
16. Greene, W. H. (2003). *Econometric Analysis*, Prentice Hall. New Jersey, 16.
17. Gwartney, J. (2009). Institutions, economic freedom, and cross-country differences in performance. *Southern Economic Journal*, 75(4), 937–956. Retrieved from <https://search.proquest.com/docview/212147017?accountid=12217>
18. Gwartney, J., Lawson, R. (2003) The concept and measurement of economic freedom, *European Journal of Political Economy*, Volume 19, Issue 3, 405-430.

19. Gwartney, J., Lawson, R., Hall, J., & Murphy, R. (2018). *Economic Freedom of the World*.
20. Hair, J. F., Black, W. C., Babin, B. J., Anderson, R. E., & Tatham, R. L. (2010). *Multivariate data analysis*. Upper Saddle River, NJ: Prentice hall.
21. Lee, C. C., & Lin, C. W. (2016). Globalization, political institutions, financial liberalization, and performance of the insurance industry. *The North American Journal of Economics and Finance*, 36, 244–266. <https://doi.org/10.1016/j.najef.2016.01.007>.
22. Mahmood, K., & Azild, T. (2011). Economic Freedom Verses Economic Growth: Cross-Countries Analysis in the form of ARDL Approach, 1(1), 14–25.
23. McMullen, J. S., Bagby, D. R., & Palich, L. E. (2008). Economic freedom and the motivation to engage in entrepreneurial action. *Entrepreneurship Theory and Practice*, 32(5), 875–895.
24. Minichilli, A., Corbetta, G., & MacMillan, I. C. (2010). Top management teams in family-controlled companies: “Faminess”, “faultlines”, and their impact on financial performance. *Journal of Management Studies*, 47(2), 205–222. <https://doi.org/10.1111/j.1467-6486.2009.00888.x>.
25. North, D. (1990). *Institutions, Institutional Change and Economic Performance (Political Economy of Institutions and Decisions)*. Cambridge: Cambridge University Press. doi:10.1017/CBO9780511808678
26. North, D. (1991) Institutions. *Journal of Economic Perspectives*, Volume 5, Number 1, Winter, 97–112.
27. Orlitzky, M., Schmidt, F. L., Rynes, S. L., & Rynes, S. L. (2003). Corporate Social and Financial Performance: A Meta-Analysis Corporate Social and Financial Performance: A Meta-analysis, (March), 403–441. <https://doi.org/10.1177/0170840603024003910>.
28. Peev, E. (2015). Institutions, economic liberalization and firm growth: evidence from European transition economies. *European Journal of Law and Economics*, 40(1), 149–174. <https://doi.org/10.1007/s10657-014-9450-3>.
29. Popper, K. (2005). *The logic of scientific discovery*. Routledge.
30. Santos, G., Murmura, F., & Bravi, L. (2018). SA 8000 as a Tool for a Sustainable Development Strategy. *Corporate Social Responsibility and Environmental Management*.
31. Segura, L., Formigoni, H., David, F., & Abreu, R. (2016). *The influence of women on earnings management: Public companies in Brazil. Women and Sustainability in Business: A Global Perspective*. <https://doi.org/10.4324/9781315546834>.
32. Soares, R. O., & Kloeckner, G. de O. (2008). Endividamento em firmas com alta propensão à expropriação: o caso de firmas com um controlador. *Revista de Administração de Empresas*, 48(4), 79–93. <https://doi.org/10.1590/S0034-75902008000400008>.
33. Sufian, F., & Habibullah, M. S. (2010). Does economic freedom fosters banks’ performance? Panel evidence from Malaysia. *Journal of Contemporary Accounting & Economics*, 6(2), 77–91. <https://doi.org/10.1016/j.jcae.2010.09.003>.
34. Vega-Gordillo, M., & Alvarez-Arce, J. L. (2003). Economic Growth and Freedom: a Causality Study. *Cato Journal*, 23(2), 199.
35. Yoshikawa, T., & Rasheed, A. A. (2010). Family control and ownership monitoring in family-controlled firms in Japan. *Journal of Management Studies*, 47(2), 274–295. <https://doi.org/10.1111/j.1467-6486.2009.00891.x>.



## PROBLEMS OF FINANCIAL RISK MANAGEMENT

**Sarvar Alijan**

*Azerbaijan State University of Economics, Azerbaijan*

### ABSTRACT

*The article reveals the essence, meaning and causes of financial risks. In relation to the concepts of “risk” and “uncertainty”, various scientific and theoretical views of economists were investigated and appropriate generalizations were made. The similarities and differences between the concepts of “risk” and “uncertainty” were clarified, and it was emphasized that risk is a potential threat and an absolute reality, with the possibility of deviation from the established levels of actual results of economic activity and the possibility of an adverse event. The theoretical and methodological foundations of financial risk management are studied, the role of risk management in the sustainable development of the company is considered, management decisions based on risks are justified, and the classification of risks is specified. The ongoing work on the formation of an information base for managing financial risks, identifying risks, assessing risks, identifying opportunities to reduce risks, strengthen or improve risk control, etc. processes are described in detail. The possible risk losses to which commercial banks are exposed are identified by applying stress testing, risk mapping and value at risk methods in assessing financial risk. In the management of financial risks, diversification of investments, financial restrictions and storage in reserves of some funds, risk insurance, hedging operations and special methods of saving financial resources are widely used. The hedging method is used to reduce the negative effects of possible fluctuations in the exchange rate in the banking sector, on stock exchanges and in commercial activities. There are reasonable proposals and recommendations for improving the financial risk management mechanism.*

**Keywords:** *financial risk, diversification, limitation, risk insurance, risk avoidance, risk management*

### 1. INTRODUCTION

In today's globalized world, it is impossible to imagine entrepreneurship and the economy as a whole without risk. For the first time, Adam Smith created a “risk premium” in the form of entrepreneurial income to offset any potential business risks. An entrepreneur puts his financial and material resources, time, labour and reputation at risk, takes responsibility for making decisions in the course of business activities, and this determines the priorities and efficiency of the company's financial and economic activities. Risk is the uncertainty that arises when implementing management decisions, leading to negative and undesirable results that negatively affect the company's key goals and strategic goals. Management of financial risks reflecting various aspects of entrepreneurial activity (currency, commercial, credit, investment, tax, etc.), begins with its identification, which means that all possible factors of their occurrence and their ranking according to the degree of influence on sustainable and steady economic development identified. *Risk factors are those that affect the current state of the company's financial and economic activities.* From this point of view, issues related to the disclosure of the reasons for the occurrence and effective management of financial risks are of particular importance, and there is a great need for their scientific research.

### 2. FINANCIAL RISK: DEFINITION, NATURE, AND CAUSES

The risk in entrepreneurship is not only a potential threat, but also an absolute reality. There are different opinions about the concept of risk. Economists express risk as a deviation from the planned level of actual business results. From the point of view of mathematicians, risk is the

probability of an undesirable event occurring. *There are various types of risks in entrepreneurship: production risk, commercial risk, investment risk and financial risk.* Financial risk occurs when an economic entity interacts with banks and other financial institutions and has a negative impact on its financial and economic activities. The impact of financial risk on the company's performance is manifested in two ways:

- financial risk has a direct impact on the profitability of the company's financial operations;
- financial risk is the main risk factor for bankruptcy of an enterprise.

In the economic literature there are different views on the concept of risk. For example, according to a group of economists, risk is an economic category that eliminates uncertainty and allows you to assess the probability of achieving a predetermined goal [1,2]. Another group of economists claims that risk is a potential threat from certain natural phenomena and specific features of human society, potential losses from accidental adverse events [3,4]. Some economists use the concepts of “risk” and “uncertainty” as synonyms and accept them as equal [5,6]. In our opinion, “risk” and “uncertainty” are fundamentally different concepts. Thus, risk implies an assessment of possible events. Risk assessment is necessary when making appropriate management decisions. The lack of reliable information about the potential volume of demand for manufactured products can lead to various risks for participants of the investment project. Under conditions of uncertainty, the number of analysis methods is significantly limited, and at the time of decision-making, game theory methods are mainly used. Financial risk is the assumption that the results of financial and economic activities (income, profit, etc.) planned by the participants of the enterprise can not be achieved. *Financial risks include currency, tax, credit, inflation, deposit, investment, liquidity, financial instability, and so on.* Effective financial risk management in the context of market relations is one of the most important and complex issues of sustainable and steady development of the financial and economic activities of the company. Financial risks may arise as a result of the company's planned activities in an uncertain economic environment under the influence of external and internal factors, which may lead to losses, non-receipt of income or bring additional expenses.

*The reasons for financial risks can be grouped according to the following criteria:*

- by origin: external and internal factors;
- by the degree of influence on management effectiveness: progressive and regressive
- by exposure duration: temporary and permanent;
- for influence on financial and economic activities: primary, secondary and minor.
- by economic nature and by field of activity: organizational, social and technical.

Innovative methods of financial management are aimed at ensuring sustainable economic growth and competitiveness. Thus, an early study of the causes of financial risks and the implementation of specific measures to eliminate or reduce their impact is an important prerequisite for the development of entrepreneurship.

### **3. CONCEPTUAL FRAMEWORK FOR FINANCIAL RISK MANAGEMENT**

The conceptual approach to the development of theoretical and methodological foundations of financial risk management is due to the fact that the innovative development of the economy is determined by the amount of synergetic effect obtained from the organization of economic entities as a whole. A characteristic feature of financial risks is that financial risks, on the one hand, are an object of management, and on the other-an integral part of the economic system. In addition, financial risk parameters are considered in the process of managing them. The financial risk management system in the context of the subject-object approach, on the one hand, covers part of the overall management, and on the other hand, in certain cases, it is at a

higher level. If an economic entity is in a state of risk and a decision is made to manage it, the risk situation may lead to different conclusions, which can be considered as positive (profit) and negative (loss). If you want to keep your revenues high, you should prevent risk as much as possible by doing a good risk management and minimize your income loss. Therefore, good risk management is very important. You can detect any problems that you may encounter with effective risk management and take measures to avoid losing money.

*The concept of financial risk management includes three basic conditions [7, p.197-198]:*

- disclosure of significant financial results of an economic entity in the face of risk;
- ability to respond to negative results of an economic entity;
- development of methods to eliminate or reduce the possible negative consequences of financial decisions, that is, methods for reducing financial risks.

*In the theory and practice of risk management, there are three main areas [8]:*

1. A system of measures aimed at preventing risks;
2. Minimization of negative consequences of risks faced by the business entity;
3. Getting as much additional income and commercial benefits as possible under risk conditions.

*The main goal of financial risk management is to ensure the financial security of the enterprise in the process of its sustainable development and prevent a decrease in its market value. To achieve this goal, the following tasks must be completed:*

- identification of high-risk areas of activity that pose a threat to the company's financial security;
- a comprehensive assessment of the probability of occurrence of risk and possible financial losses associated with it;
- ensuring that the ratio of risk to profit from financial transactions is reduced;
- ensuring the reduction of possible financial losses arising at the time of carrying out risky activities.

Risk management performs methodological, analytical, regulatory and theoretical functions at the stages of financial risk management. The stages of the financial risk management process are as follows: formation of an information base; risk identification; risk assessment; assessment of possibilities for reducing the level of risk; choosing criteria for making risky decisions; the adoption of risky decisions; selection and application of methods for neutralizing possible negative consequences of risks; risk control; monitoring.

#### **4. FINANCIAL RISK ASSESSMENT**

Determining the level of risk is one of the most important tasks of risk management. It is impossible to make effective decisions on risk management without determining the level of risk, referring to objective criteria and methods. In the economic literature, the level and content of risk varies depending on different criteria. For example, it is not possible to define the boundaries between "acceptable risk", "crisis risk", and "catastrophic risk" according to the same criteria. Thus, the allowable (permissible) risk is the loss of the company's profit in whole or in part; critical risk is the loss of income and cash from operations; catastrophic risk is based on the criteria of a bankruptcy of a company or loss of its assets. The nature and essence of the problem of assessing financial risk differ in different business entities, for example, in one company it may be related to bankruptcy and non-fulfillment of planned tasks, and on the other with sales and personnel issues.

Therefore, the causes of the problem must first be identified and addressed in a timely manner. To do this, risk analysis should be carried out in the following stages:

- risk measurement;
- identification of risk factors;
- risk assessment;
- making a decision about risk.

There are various categories of risks in financial transactions. Value at risk, stress testing and risk mapping techniques are used to assess these risks. The use of risk assessment methods allows you to determine the amount of potential losses that may be incurred as a result of the risks that a commercial bank is exposed to.

*The following methods are used in risk management in commercial banks:*

- process optimization - used to reduce time, money, motivation and other losses that occur in different processes;
- strengthening and improving control - This method involves strengthening control in risky areas and reducing risk through the use of new control mechanisms;
- application of limits - used to set limits on each transaction and authority in the bank and maintain them at a certain level;
- insurance - minimization of risks associated with a number of transactions through insurance.

*Market risk, portfolio risk, interest rate risk and currency risk are measured using value at risk (VaR). Three basic methods are used to calculate VaR:*

1. The analytical method is based on the assumption of a normal distribution of risk factors and requires an assessment of the normal distribution in calculating VaR. After this estimation, based on statistical analysis, the VaR indicator is calculated by multiplying the obtained standard deviations by the coefficient of the chosen degree of confidentiality.
2. The Historical Simulation Method is a simplified form of the Monte Carlo simulation method. Here the scenarios are created on the basis of historical data, and the portfolio is estimated using historical changes in risk factors and, accordingly, the profit and loss of the portfolio are calculated. In short, the calculation of VaR in the historical modeling method is based on determining profit or loss from price fluctuations.
3. The Monte Carlo simulation method determines the simulation of random quantities and the calculation of their characteristic distribution. Random scenarios are created here, and the portfolio is evaluated using artificial changes in risk factors. Such artificial modeling of risk factors allows you to choose any type of risk probability and more accurately calculate VaR.

Scenario analysis, stress testing, a probability tree, and other methods have been used in calculating VaR in recent years in terms of financial risk.

## **5. IMPROVING THE FINANCIAL RISK MANAGEMENT MECHANISM**

In the system of financial risk management, internal mechanisms for their neutralization play an important role. Internal mechanisms to neutralize financial risks include a system of methods to minimize the negative consequences that are selected within the enterprise. In the modern era, internal mechanisms of neutralization cover most of the financial risks. In this regard, the issue of financial risk regulation has theoretical and practical significance.

The main objective of financial risk management is the development and implementation of measures to reduce them to an acceptable level. *Methods to reduce financial risk in the economic literature include diversification of investments, limiting and reserving funds, risk insurance, hedging transactions and specific methods for reducing financial resources.* Credit restrictions, collateral, or loan guarantees are a special way to reduce bank risks.

*Diversification* refers to the process of investing capital in various sectors of the economy in the form of investments or loans. This process reduces the investment risk and contributes to diversified economic development, and also allows you to avoid some risks.

*A limitation-* is the setting of the lower and upper limits, which help reduce the risk. The method of limitation varies depending on the duration, structure and effectiveness. The boundaries of market risk should be regularly reviewed, aligned with the annual budget and planning process, and take into account risk-related actions and strategic decisions. Credit limits must be set for the opposite party or client, and companies must check for credit limits before accepting new loan commitments.

Reserving funds can be considered as an alternative to insurance, since the use of these funds to cover the losses of an enterprise is called self-insurance. *The creation of funds by an entrepreneur that can compensate for possible losses in production and trade activities is the basis of self-insurance.* The main purpose of self-insurance is to promptly eliminate difficulties that arise in the course of financial and economic activities.

Risk insurance is, in essence, the transfer of risks to another business entity for a fee. The risk insurance system mainly uses property insurance and liability insurance. In the insurance process, insurance coverage is provided for all types of financial risks. At the same time, insurers do not limit the amount of negative consequences of financial risks, that is, it is determined by the real value of the insurance object, the amount of insurance and the amount of insurance premium payable.

*Transaction hedging* is a system for launching futures contracts in order to reduce the negative consequences of possible changes in exchange rates in the future.

*Hedging is used to identify various methods of insurance of currency risks in banking, exchange and commercial practice. Hedging is a forward transaction between a buyer and a seller to insure (protect) their business or payment instruments against financial losses as a result of market volatility.*

*One of the most effective methods used in financial risk management is the compensation method.* A high labor-intensive compensation method provides the solution to the following problems [9, p. 57]:

- strategic planning of the company;
- providing compensation for possible financial losses by reflecting the penalties system in the contract;
- improving the working capital management of the company;
- collection and analysis of additional information about financial markets;
- forecasting trends in the external environment and financial market conditions.

Reducing financial risks requires maximum flexibility and targeted action. However, an important issue is the distribution of risks between the parties and the determination of losses associated with the risk.

*An integral part of the financial risk management process is their regulation.* Risk management is carried out in the following sequential stages: risk acceptance, risk minimization, risk transfer (distribution), and risk avoidance.

## 6. CONCLUSION

Financial risk is the probability that the company will not receive the expected income (profit) as a result of its pre-planned activities under the influence of external and internal environmental factors, or that additional income will be received and losses will occur. Financial risks include investment risk, inflation risk, credit risk, tax risk, currency risk, deposit risk and much more. Financial risk management should be carried out in the following stages: formation of an information database; identification of risks; risk assessment; identification of opportunities to reduce risk; selection of methods to eliminate possible negative consequences arising from risks; organization and monitoring of risk control. Financial risk management uses specific methods to diversify investments, limit resources, reserve funds (self-sufficiency), insure risks, hedge transactions, and reduce financial resources. Market risk, portfolio risk, interest rate risk and currency risk are measured using the value at risk (VaR). Three main methods are used to calculate VaR indicator; analytical method, Historical simulation method and Monte Carlo simulation method. It is important to develop and implement systematic measures to eliminate the possible negative consequences of risk by applying methods such as risk reduction, risk prevention, risk elimination and risk compensation.

## LITERATURE:

1. Abchuk V.A. Risks in business, management and marketing. SPb Publishing House of Mikhailov V.A. Moscow, 2006 .-- 480 p
2. Blank I.A. Financial risk management. Training course. Kiev, Nika - Center, 2006. - 503 p.
3. Colass B. Management of the financial activity of an enterprise: Problems, concepts and methods. Moscow, finance, 1997.
4. Fomichev A.N. Risk Management: Textbook, Moscow, Publishing and Trading - Dashkovik Corporation, 2008. - 376 p.
5. Lyuty I.A., Kuliev R.A. Investment activities. Baku, 2009 .-- 400 p.
6. Maksimov M. M., Ignatiev, A. V. et al. Management: the Textbook. Moscow, Banks and exchanges, UNITY, 1998. – 427 p.
7. Sharpe W., Alexander G., J. Bijman. Investments. trans. from the English., INFRA-M, 2003. – 1028 p.
8. Sheremet A.D., Sayfullin R.S. Business finance. Moscow, INFRA - M., 1999 .-- 343 p.
9. Volkov I.M., Gracheva M.V. Design analysis. Moscow, INFRA - M., 2004 .-- 495 p.

## PERSISTENCE IN INNOVATION AS AN ENHANCER OF SUSTAINABLE GROWTH

**Joana Costa**

*GOVCOPP, DEGEIT Universidade de Aveiro, Portugal  
joanacosta@ua.pt*

**Diana Braga**

*DEGEIT Universidade de Aveiro, Portugal*

### **ABSTRACT**

*The impact of innovation in economic growth is widely explored, thus, in the last decades it has been understood that along with innovation per se, one must address the continuity of these behaviours over time. Analysing the details of innovation persistence helps understanding firm dynamics, effectiveness of policy actions, raising productivity thus sustainability. Persistence of innovation is empirically explored using technological innovation, and continuity of innovative behaviours in the same innovation type; non-technological innovation types are somehow neglected and, the existing literature may not apply to the innovation types in a generalised manner and iterative persistence of innovation has not been detailed so far. Understanding the specific characteristics of each innovation type will grant the design of fine tuning policy actions accommodating the array of particularities. Moreover, the effect of the absorptive capacity and the open innovation strategy has not been connected to the innovation types by the existing literature. The present article analyses persistence of innovation using a dynamic panel encompassing 2147 firms operating in all economic sectors in Portugal, observed from 2008 to 2014, covering three editions of the Portuguese Community Innovation Survey (CIS). Using the random effects probit model, interactive processes of innovation are evidenced, reinforcing the singularities of each innovation type. As a consequence policy programs financing the same innovation type will fail to feed innovation cycles. Open innovation strategies seem to reinforce intermittence and public funds are helpful only for technological innovation. Empirical findings encourage differentiated public policies targeting the different innovation types avoiding the one size fits all approaches in use at present as a vehicle to promote sustainability*

**Keywords:** *Persistence in Innovation, Sustainability, Random Effects Probit, CIS*

### **1. INTRODUCTION**

The concept of innovation has been developed over time, based on multiple perspectives. Since the early proposal of Schumpeter (1934) innovation involves the introduction of new products, new methods of production, the opening of new markets, the acquisition of new supply sources and the adoption of new organization forms. However, Freeman (1982) considered essential to distinguish invention from innovation, the latter being an idea, model or design of a product or process, which assumes the role of innovation when validated by the market. Subsequently, Dosi (1988) stated that innovation is the search and discovery, experimentation, development, imitation and adoption of new products, production processes and new organizational structures. Even though, in the recent years, the analysis of innovation has been considered under a different perspective, focusing on the continuity of these activities. Persistence in innovation can improve the understanding of firm dynamics, anticipate the effects of the different policy actions, correct macroeconomic disequilibria, help in designing the correct policies to boost R&D and, consequently, generate prosperity. Given the central role of innovation as driver of firm performance, innovation persistence will help in the creation of competitive advantages at the firm and the country level (Hecker and Ganter, 2014).

When a firm is persistent in its innovative activities, it accumulates feedbacks creating a relevant stock of knowledge. Firms with this ability will be more prone to proceed with new innovations, raising the probability to persist and succeed in innovation (Suárez, 2014). The debate on persistence in innovation grasps the attention in different vectors such as industrial economics and firm dynamics (e.g.: Nelson and Winter, 1982; Tavassoli and Karlsson, 2015), evolutionary economics (e.g.: Nelson and Winter (1982)), virtuous accumulation cycles (e.g.: Mansfield (1968); Stoneman (1983)). The empirical research in persistence has strongly reinforced an originally purely theoretical framework (e.g.: Cefis (2003); Frenz and Prevezer (2012); Suárez (2014); Triguero and Córcoles (2013); Altuzarra (2017)), along with the development for public-policy design (e.g.: Hecker and Ganter (2014); Le Bas and Scellato (2014)). Understanding the idiosyncrasy of persistence in innovation will help entrepreneurs, policy makers and the Academia to get a long run vision of the industry dynamics. These insights will help forecasting the long run industry progression and to anticipate the effect of public policies affecting R&D and innovative activities. In an ecosystem of scant public resources and the compelling need for efficiency, the existence of intertemporal innovation spill overs cannot be neglected when analysing public funding (Hecker and Ganter, 2014). The existence of a knowledge legacy will put existing innovators in the forefront of recipients of new funds; the demonstration of this hypothesis should create some queries about whose firms to support, and, in extreme in the rational of supporting non-innovative firms, being them start-ups or not (Aghion, 2017). The article analyses persistence of innovation by means of a dynamic panel including 2147 firms from the different economic sectors. These firms are traced over three waves of the Portuguese Community Innovation Survey (CIS), covering the period between 2008 and 2014. Empirical evidence shows that nearly 35% of the firms in the panel are persistent in innovation. The empirical results reinforce the existence of different pattern according to the innovation types. Technological persistence has been more largely explored than the other types and it seems that service, organisational and marketing innovation has to be approached differently. To empirically test persistence in the different types of innovation a random effects probit model is used, creating 12 alternative models to compare the (dis)similarities among them. Firms do have characteristics which are time invariant, this problem is approached introducing in the panel the Wooldridge correction (2005), Furthermore, there is a probability identify time-correlated characteristics affecting the propensity to persist in innovation. The effect of unobserved time correlated effects is called in the literature as “spurious state dependency”, and as mentioned by Peters (2009) and Suárez (2014), must be corrected by means of the separation of the unobserved firm heterogeneity and initial conditions from causal effects of former innovation actions, in doing so we separate innovation persistence into spurious and effective state dependence, with the coefficients producing information about the later. The determinants of state dependence are discussed in the light of the competing paradigms of market power and innovation - Schumpeter, 1934, 1942; the success-breeds-success - Mansfield, 1968; Stoneman, 1983; the sunk costs - Sutton, 1991; the evolutionary - Nelson and Winter, 1982. The rest of the paper is structured as follows. The next section comprises a review of the literature and presents the main hypotheses in analysis. Section 3 provides a short database description. Section 4 presents and discusses the econometric results. The final section presents the conclusions, opposing the present results with the existing literature and highlights some policy recommendations.

## **2. LITERATURE REVIEW**

### **2.1. Persistence in Innovation**

Innovation, according to the Oslo Manual is defined as the introduction of a new or significantly improved good or service in terms of its characteristics or intended uses, or the implementation of production, marketing, or organizational issues (OECD, 2005). However, the major focus of



the present research is not on innovation as a single phenomenon but its continuation over time, which is termed as Persistence in Innovation. The issue of Persistence in Innovation goes back to the Joseph Schumpeter's two structural conceptions of technological change: "creative destruction" and "cumulative creation", developed in *Theory of Economic Development* in 1934 and *Capitalism, Socialism and Democracy* in 1942, respectively named by (Nelson and Winter, 1982) as Schumpeter Mark I and Schumpeter Mark II. According to the Schumpeter Mark I, technological change is defined as a random process, driven by a group of homogeneous companies seeking a set of technological change opportunities available to all of them. Innovation promotes monopoly power, but only temporarily, as other companies will try to replicate these innovations. In this paradigm new companies replace those that were already established in a continuous race towards transitory monopoly power (Malerba, Orsenigo, and Peretto, 1997). Under the Schumpeter Mark II conception, technical progress is associated with the existence of large companies competing in Oligopolistic markets. Innovations trigger new innovation processes by means of new investments resulting in accumulation processes, to ensure the company's perpetuation in the market, thus generating a virtuous cycle of accumulation and feedback (Suárez, 2014). Moreover, the existence of barriers to entry will foster high market power to the incumbent oligopolists which tend to become persistent innovators (Gilbert and Newbery, 1982; Le Bas and Scellato, 2014). According to Peters (2009), there is persistence in innovation when a firm which has innovated in one period continues to innovate in the following. On the other hand, to Ganter and Hecker's (2013), persistence describes the influence that past innovation activities have on the behavior and success of current and future innovations. A positive relation between past innovations and the propensity to innovate at present is Suárez's view on the definition of persistence of innovation activities, being associated with investments in firms that allow them to achieve efficiency gains (Frenz and Prevezer, 2012; Suárez, 2014). So, Innovation Persistence is defined as the degree of continuity of the innovative activity over time. The fact that innovations have been successful in the past increases the likelihood of their success in the present (Flaig and Stadler, 1994). Although firms' propensity to innovate depends on market structure in which they operate, the demand and the expected costs, the successes of past innovations provide a strong state dependence on the present innovation process (Triguero and Córcoles, 2013). Persistence, considered as true state dependence is defined as a positive causal relationship between the decision to innovate in one period and the likelihood of innovating in the next (spurious state dependence occurs if unobserved attributes are correlated over time, and not properly controlled). In this way, past innovation seems to affect current innovation, because it captures the effects of unobserved persistent characteristics (Altuzarra, 2017). The distinction between spurious and true persistence is decisive for economic policy design since, as if the state dependence is spurious the performance of the firm is not likely to be influenced by economic policy in the long run. However, if state dependence is true, an accurate Policy design has longterm effects on firm performance (Peters, 2009). In addition to the previously mentioned conceptions of innovation and market power (Schumpeter, 1934, 1942) three additional frameworks will provide a deeper help explanation to the existence of innovation activities that persist over time as identified as identified in previous studies (e.g.: Le Bas and Scellato, 2014; Tavassoli and Karlsson, 2015).

## 2.2. Persistence Approaches

The success breeds success hypothesis, firstly proposed by Mansfield (1968) and (Stoneman, 1983) argues that the success of previous innovations can increase the technological opportunities available to firms, increasing the probability of success in future innovations. The positive achievements of the past will encourage the development of new innovative cycles (e.g.: Mansfield, 1968; Scellato and Ughetto, 2010). This hypothesis relies on the fact that

successful past innovators have an increased market power, benefiting from the results achieved by former innovations. Allying market power to abnormal profits, they reduce their financial constraints thereby being able to develop new innovation cycles, fed by the results of the former. The success breeds success hypothesis reinforces the fact that innovation leads to profitability, and this will be the foundation of the future innovation processes. Under this concept and considering market power and positive finance it seems more likely that large companies will be persistent (Flaig and Stadler, 1994; Le Bas and Latham, 2006). Additionally, firms succeeding in innovations are able to achieve profits otherwise impossible. These results reduce the aversion to these expenditures of either investors, shareholders or borrowers expecting new innovations to be achieved. This leverages the capacity to continue investing in R&D activities that promote future innovations, moreover, there will be no need for external sources of finance, such as bank credit, as the equity will cover these costs. The availability of liquidity promotes trust and reinforces firm credibility in among investors (Tavassoli and Karlsson, 2015). So is past innovative success allows the existence of artificial monopoly profits, there is an interest in obtaining them for longer time span; aiming for new profits, shareholders will approve new R&D expenditures, and due to greater financial availability, there is a higher the possibility to increase the new innovation activities, often interrupted due to financial constraints or lack of external finance. The concept of sunk costs is presented as an alternative hypothesis to explain persistence of innovation activities. It was firstly developed by Sutton in 1991. The author argues that investing in innovation activities is not an easy decision to make for firms, as they incur initial costs that are often high and unrecoverable (e.g. for the installation of R&D laboratories, for the recruitment of qualified people and for training of employees). In addition to the initial costs already mentioned, continuous funding is essential throughout the innovation process until the product is launched on the market (Sutton, 1991). Inside the firm there is risk aversion, and investors, seeking for the maximum return on investments will be reluctant to allow the directioning of finance to activities with uncertain outcomes. Once the investment is made, it seems irrational to stop those activities as the spending is small compared to the potential return. But, this irreversibility is considered as a barrier to take the first step. Therefore, firms that decide to invest in R&D activities tend to invest continuously in the development of these activities creating a stock of physical and human capital that, in the long run, contributes to the existence of continuous innovation processes and efficiency gains with lower costs of production (Cohen and Klepper, 1996; Máñez, Rochina-Barrachina, Sanchis, and Sanchis, 2009). The fact that initial costs are high leads to barriers to entry for firms that are not innovative but want to start innovating. This approach reinforces the belief in virtuous cycles of accumulation as those firms which have entered the innovation process will not stop it as it seems irrational to waste the existing infrastructures and loose advantages compared to their competitors. The Evolutionary Theory of Innovation argues that experience in innovation activities is associated with increasing dynamic returns, either in the form of learning-by-doing or in learning-to-learn (Nelson and Winter, 1982). The technological knowledge recognized as an economic good has characteristics of cumulateness and non-exhaustiveness, which have great implications for the persistence of innovation, since the new knowledge acquired helps to improve the already existing inside the company and is the starting point for the future updates of new knowledge, thus creating a competitive advantage for innovators (e.g.: Teece, Pisano, and Shuen, 1997; Antonelli, Crespi, and Scellato, 2013; Le Bas and Scellato, 2014). Once more, the existing stock of knowledge develops an increased ability to capture new innovation opportunities inside the firm, with a prepared human capital whose absorptive capacity permits the acquisition of new information from the innovative milieu. The different theories that seek to justify the existence of persistence of innovation activities are complementary to each other, since the interaction of the success breeds success hypothesis and the knowledge accumulation gives rise to a virtuous

circle, where the financial profits achieved in R&D activities, allow the learning process to continue (Le Bas and Latham, 2006). Moreover, since successful innovations in international markets increase corporate profits and reduce the mistrust of banks and other financial institutions. The increase in external capacity occurs because successful past innovations are a positive sign for future innovation processes, since the ability of the firm is boosted due to the accumulation of knowledge. Firms with past successful innovative processes will evolve to new innovations as they are intrinsically more capable as they have learnt from the past (Tavassoli and Karlsson, 2015). With respect to the complementarity between the sunk costs and knowledge accumulation assumptions, it is clear that sunk costs are important in building the knowledge accumulation, since the existence of previous innovation processes will reduce the associated costs and will increase of knowledge necessary for the firm to continue to innovate and accumulate knowledge (Antonelli et al., 2012). Believing in the endogeneity is this process and its continuity over time should reinforce the importance and the desirability of these fields to absorb public finance, as, once the conditions are created by means of subsidization, the firm will continue this innovative cycle with no need to rely upon any other type of public funding. As all perspective points to the continuity of those processes, it seems straightforward that policy makers should subsidize already existing innovators; innovators that succeeded in the past or the construction of infrastructures to support innovative activities such as R&D labs because once the virtuous cycle starts it is to some extent unstoppable.

### 2.3. Hypothesis in test

From the theoretical analysis, innovation types, technological regimes and firm characteristics do affect the propensity of firms to start and continue innovation activities. Likewise, the literature points towards the existence of different possibilities in terms of the innovation strategies. The model about to be estimated allows for continuities and discontinuities along the time span (three-time periods). The conventional hypothesis concerning persistence in innovation points towards the interdependence of the past innovation strategies with the present, so, firms will continue in innovation due to their dependence to the past (state dependence) or will continue as non-innovative. Empirical evidence shows that firms have discontinuities in their innovative actions, but it is expected that firms which have performed innovation in the past continue to innovate at present, at least until they complete the innovation cycle or to approach the product lifecycle. The empirical analysis will provide information to discuss the hypothesis listed in the table below:

Hypothesis	Description
H1	Being persistent in innovation in the past will enhance the probability to continue innovating at present
H2	Higher levels of absorptive capacity will enhance the probability of persistent innovative behavior
H3	Higher levels of human capital will increment the probability to persist in innovation
H4	Firms with a larger size are more prone to continue in innovation
H5	The economic sector defines the persistence pattern

*Table 1: Hypothesis in Test*  
*Source: Authors' elaboration*

### 3. METHODOLOGY AND DATABASE CONSTRUCTION

The persistence of innovation according to the different frameworks already presented in the former sections depends on the success obtained in  $t-1$ , that is, the success obtained in the past will influence the continuation of innovation in the present. However, it is considered that in countries that are not frontrunners in innovation, firms are persistent if they carry out different types of innovations in different years. Data from three waves of the Community Innovation Survey (CIS), was put together, to obtain information on the characterization of the firms' innovation activities. Analysing the persistence of innovation activities throughout the data collected in the CIS, requires the construction of a balanced panel, using the balanced panel is relies in the fact that persistence requires that companies are to be observed in different periods of time, as persistence can only be measured when it is possible to monitor the same company for more than a period, this explains the fact that the panel has fewer companies (than those responding in each CIS wave), since they need to be present in all analysed time periods<sup>1</sup>.

### 4. ECONOMETRIC RESULTS

Given the nature of the dependent variable, innovation persistence, the model choice is a probit model of dynamic random effects. The firm is classified as persistent in innovation if the innovative past of the firm influences the present innovative behaviour, being therefore binary; insofar as it has an autoregressive component (having done innovation in the past explains the fact of performing innovation in the present), that is, the variable when it is out of phase becomes explanatory.

*Table following on the next page*

---

<sup>1</sup> Details concerning exploratory analysis of variables, descriptive statistics and correlations were purposefully omitted, however they can be provided upon request, as well as the empirical testing to guarantee the validity of the econometric estimations.

		Innovation in general		Product Innovation		Process Innovation		Service Innovation		Organisational Innovation		Marketing Innovation		
		Model A1	Model A2	Model B1	Model B2	Model C1	Model C2	Model D1	Model D2	Model E1	Model E2	Model F1	Model F2	
Persistence	Innovation <sub>t-1</sub>	<b>0.0276*</b> (0.0150)		0.0532 (0.1085)		<b>0.0496*</b> (0.0289)		0.07670 (0.0883)		0.0743 (0.0488)		0.0908 (0.1371)		
Dynamic innovative behaviour (default: not innovative)	Continuing <sub>t-1</sub>		<b>-0.0668***</b> (0.0150)		<b>-0.1161***</b> (0.0256)		-0.0021 (0.0240)		- (0.0280)		<b>0.1316**</b> (0.0271)		<b>-0.1582***</b> (0.0283)	
	Sporadic <sub>t-1</sub>		<b>-0.0693***</b> (0.0217)		<b>-0.1223**</b> (0.0254)		<b>-0.0448*</b> (0.0238)		- (0.0225)		<b>0.1210**</b> (0.0244)		<b>-0.2207***</b> (0.0277)	
	New <sub>t-1</sub>		0.0271 (0.0225)		0.0156 (0.0378)		<b>0.0555*</b> (0.0315)		0.0327 (0.0369)		0.0145 (0.0341)		0.0059 (0.0393)	
R&D activities	Acapacity	<b>0.2594***</b> (0.0176)	<b>0.2435***</b> (0.0166)	<b>0.1004***</b> (0.0043)	<b>0.0951***</b> (0.0040)	<b>0.1406**</b> (0.0051)	<b>0.1366***</b> (0.0048)	<b>0.0867**</b> (0.0041)	<b>0.0843***</b> (0.0037)	<b>0.0870***</b> (0.0056)	<b>0.0821*</b> (0.0046)	<b>0.1015***</b> (0.0122)	<b>0.0945***</b> (0.0047)	
	Internal Balance 1	<b>-0.3856***</b> (0.0967)	<b>-0.2731***</b> (0.0849)	<b>-0.1520***</b> (0.0221)	<b>-0.1237**</b> (0.0208)	<b>-0.1110**</b> (0.0332)	<b>-0.1987***</b> (0.0309)	<b>-0.1403**</b> (0.0195)	<b>-0.1470**</b> (0.0180)	<b>-0.0583**</b> (0.0273)	<b>-0.0203**</b> (0.0254)	<b>-0.1859***</b> (0.0329)	<b>-0.1047***</b> (0.0246)	
Education	Education_intensity	<b>0.0178***</b> (0.0041)	<b>0.0156***</b> (0.0039)	0.0063 (0.0045)	0.0005 (0.0044)	-0.0017 (0.0045)	-0.0019 (0.0044)	0.0055 (0.0040)	0.0052 (0.0040)	<b>0.0368***</b> (0.0051)	<b>0.0343***</b> (0.0048)	<b>0.0136**</b> (0.0054)	<b>0.0102**</b> (0.0050)	
Openness	Openness	0.0212 (0.0255)	0.0112 (0.0233)	0.0039 (0.0110)	-0.0022 (0.0106)	0.0046 (0.0139)	0.0060 (0.0134)	<b>0.0175*</b> (0.0097)	0.0150 (0.0095)	0.0090 (0.0130)	0.0041 (0.0125)	0.0176 (0.0135)	0.0161 (0.0129)	
Funds	Public Funds	0.0046 (0.0353)	-0.0078 (0.0321)	<b>0.0593***</b> (0.0159)	<b>0.0587***</b> (0.0143)	<b>0.0687***</b> (0.0196)	<b>0.0671***</b> (0.0184)	-0.0018 (0.0149)	-0.0035 (0.0141)	0.0189 (0.0186)	0.0238 (0.0178)	-0.0207 (0.0205)	-0.0164 (0.0185)	
Size (default: small)	Medium_size	<b>0.0303**</b> (0.0124)	<b>0.0208*</b> (0.0121)	-0.0071 (0.0122)	-0.0151 (0.0120)	<b>0.0391***</b> (0.0129)	<b>0.0397***</b> (0.0125)	- (0.0112)	- (0.0113)	0.0101 (0.0144)	-0.0025 (0.0138)	-0.0096 (0.0150)	<b>-0.0245*</b> (0.0142)	
	Large_size	<b>0.0578*</b> (0.0295)	<b>0.0507*</b> (0.0280)	- (0.0207)	- (0.0196)	<b>0.0558**</b> (0.0276)	<b>0.0480*</b> (0.0275)	-0.0196 (0.0197)	- (0.0189)	0.0423 (0.0261)	0.0235 (0.0248)	-0.0073 (0.0261)	-0.0412 (0.0251)	
Group	Group	-0.0084 (0.0143)	-0.0082 (0.0140)	0.0198 (0.0134)	0.0204 (0.0127)	-0.0007 (0.0139)	0.0005 (0.0136)	0.0009 (0.0119)	0.0016 (0.0116)	0.0248 (0.0153)	0.0199 (0.0147)	-0.0204 (0.0153)	-0.0227 (0.0149)	
Initial endogeneity and individual heterogeneity	Innov_geral_initial	<b>0.0421***</b> (0.0151)	<b>0.1022***</b> (0.0158)	0.0832 (0.0788)	<b>0.1852***</b> (0.0132)	<b>0.0509**</b> (0.0208)	<b>0.1150***</b> (0.0154)	0.0430 (0.0605)	<b>0.1664***</b> (0.0126)	0.0326 (0.0342)	<b>0.1604***</b> (0.0157)	0.0837 (0.1081)	<b>0.2504***</b> (0.0149)	
	Mean_Acapacity	-0.0034 (0.0053)	0.0030 (0.0055)	<b>-0.0172**</b> (0.0072)	-0.0100 (0.0063)	<b>0.0162*</b> (0.0065)	- (0.0071)	<b>0.0160*</b> (0.0057)	<b>0.0155**</b> (0.0053)	-0.0055 (0.0073)	0.0005 (0.0073)	-0.0088 (0.0079)	-0.0028 (0.0067)	
	Mean_education_intensity	<b>-0.0007*</b> (0.0004)	<b>-0.0006*</b> (0.0004)	<b>-0.0009**</b> (0.0004)	<b>0.0010*</b> (0.0004)	<b>0.0009*</b> (0.0004)	- (0.0004)	<b>-0.0009**</b> (0.0004)	0.0003 (0.0004)	0.0004 (0.0004)	-0.0007 (0.0005)	-0.0005 (0.0005)	<b>-0.0011**</b> (0.0005)	<b>-0.0009**</b> (0.0005)
	Mean_openness	0.0107 (0.0157)	0.0177 (0.0153)	-0.0090 (0.0155)	-0.0047 (0.0153)	0.0072 (0.0164)	0.0099 (0.0162)	-0.0219 (0.0142)	-0.0175 (0.0142)	-0.0152 (0.0189)	-0.0051 (0.0187)	-0.0152 (0.0191)	-0.0085 (0.0188)	
Sector (default: primary)	Industry	<b>0.0708*</b> (0.0379)	<b>0.0668*</b> (0.0371)	<b>0.0799*</b> (0.0483)	0.0710 (0.0459)	0.0505 (0.0438)	0.0509 (0.0430)	-0.0365 (0.0515)	-0.0388 (0.0522)	0.0101 (0.0499)	0.0091 (0.0493)	0.0449 (0.0600)	0.0420 (0.0579)	
	Services	<b>0.1075***</b> (0.0386)	<b>0.1056***</b> (0.0378)	-0.0031 (0.0481)	-0.0025 (0.0469)	0.0334 (0.0445)	0.0328 (0.0437)	<b>0.0988**</b> (0.0519)	<b>0.0951*</b> (0.0522)	0.0550 (0.0506)	0.0583 (0.0501)	<b>0.1304**</b> (0.0615)	<b>0.1314**</b> (0.0584)	
	N° of observations	4294	4446	4294	4446	4294	4446	4294	4446	4294	4446	4294	4446	
	N° of groups	2147	2147	2147	2147	2147	2147	2147	2147	2147	2147	2147	2147	

Table 2: Econometric Estimations  
Source: Authors' computation

Estimations were organised in 12 models, models 1 analyse pure persistence in innovation in general and all the innovation types. Models 2 follow the same procedure but allow for intermittences in innovations. The estimates are run based on the of dynamic random effects probit model. Models1 tests the conventional hypothesis of persistence and models 2 test unconventional persistence, which means innovation intermittence. For each model, estimates will be made for all types of innovation and for innovation in general (at least one type of innovation)<sup>2</sup>.

<sup>2</sup> Further details concerning the variables in use can be found in Appendix 1.

## 5. DISCUSSION AND POLICY RECOMMENDATIONS

Despite the large extent of empirical evidence covering the topic on innovation persistence, phenomenon is not yet fully understood. (Cefis, 2003, Clausen et al., 2012, Juliao-Rossi and Schmutzler, 2016; Altuzarra, 2017). Most of the studies focus on firms operating in the industrial sector, in Innovation leaders and conventional persistence hypothesis. Albeit, the analysis of innovation persistence seems to have far more peculiarities than those traditionally exploited in the literature. The conventional hypothesis reinforcing the virtuous cycles of accumulation neglect the natural intermittences in the innovative proves. Moreover, the determinants of innovation differ according to the innovation type. The empirical results support Schumpeter's idea of different innovation types to accommodate product lifecycle. These findings are quite new and should deserve the attention of policy makers in the promotion of sustainability cycles. The present study focused on a balanced panel of 2147 firms located Portugal, covering the time span of 2008 and 2014 and tested the hypothesis of 'true state dependence', assuming both that firms do not react to exogenous fluctuations and that they may change their innovative behavior (Continuous, New, Sporadically, and Non innovative firms) (Suárez, 2014; Costa et al, 2018).

Concerning the innovative strategy, the results only partially go along with those found in Suárez's (2014) concerning non-conventional persistence hypothesis, Past persistent innovators have a reduced propensity to continue in innovation, such as sporadic and, being new to innovation does not affect the probability to continue, driving out the hypothesis of persistence. In the aggregate level, the effects of past innovative strategies do not differ from one innovation type to another. Additionally, the exploratory analysis, provided by the transition probability matrices, unveil a very high degree of state dependence or pure innovation persistence, nevertheless the econometric estimations reported in models 1 fail to provide statistical support for this belief. It seems that the pattern of persistence traced in this model is spurious rather than pure, which means that the factors explaining persistence are closer to the firm characteristics rather than past innovative behaviour. Among firm characteristics it determinant the effect of the firm absorptive capacity, its open innovation strategy (combine internal and external investments in intangible assets) and punctually the skills of the labour force and the public funds. Contrarily to the previous Portuguese analysis (Costa et al., 2018, 2020), reliance on innovation sources fails to affect innovation persistence.

Another surprising result is the effect of size, as one can observe a scale effect when focusing on innovation in general, and process or service innovation. In addition, concerning product innovation large firms have a reduced likelihood to persist in innovation. The different types of innovation are transversally affected by the firms' absorptive capacity and open innovation strategies. However, when it comes to the reliance on public funds, the only innovation types affected by this determinant are product and process innovation. Surprisingly, the skills of the labour force fail to affect persistence on what concerns product, process and service innovation. The specificities of these results have important implications in terms of the public policy. As innovation persistence is not verified in our panel, it seems that the innovation policy programs fail to achieve their targets, being incapable of generating virtuous cycles of accumulation. Firms, when on themselves, do not persist in innovation, forcing policy makers to create the accurate mechanism to overcome the failures in continuity. Perhaps the innovation policy should focus on the factors forcing the firms to interrupt their innovative paths. So, the reliance on subsidies should not be singular, nor persistent, it should help firms in starting the innovation cycles and supporting them in punctual moments when they are forced to stop. It seems evident that innovation policy requires commitment; it should not change in the short run according to short run fluctuations, economic or electoral cycles.

It persistence fails to be achieved firms virtuous cycles will be broken and intertemporal spillovers are unlikely to be created. According to the results, there might be a rational to encourage public policies targeting small firms with high absorptive capacity, with open innovation strategies being either in the secondary or tertiary sectors if the funding goal is to promote innovation in a persistent scheme.

#### LITERATURE:

1. Altuzarra, A. (2017). Are there differences in persistence across different innovation measures? *Innovation*, 19(3), 353–371
2. Antonelli, C., Crespi, F., & Scellato, G. (2012). Inside innovation persistence: New evidence from Italian microdata. *Structural Change and Economic Dynamics*, 23(4), 341–353.
3. Antonelli, C., Crespi, F., & Scellato, G. (2013). Internal and external factors in innovation persistence. *Economics of Innovation and New Technology*, 22(3), 256–280.
4. Battisti, G., Gallego, J., Rubalcaba, L., & Windrum, P. (2014). Open innovation in services: knowledge sources, intellectual property rights and internationalization. *Economics of Innovation and New Technology*, 24(3),
6. Bryson, J., & Monnoyer, M. (2004). Understanding the relationship between services and innovation: the RESER review of the European service literature on innovation, 2002. *The Service Industries Journal*, 24(1), 205–222.
7. Carvalho, L., Costa, T., & Caiado, J. (2013). Determinants of innovation in a small open economy: A multidimensional perspective. *Journal of Business Economics and Management*, 14(3), 583–600.
8. Cefis, E. (2003). Is there persistence in innovative activities? *International Journal of Industrial Organization*, 21(4), 489–515.
9. Cefis, E., & Orsenigo, L. (2001). The persistence of innovative activities: A cross-countries and cross-sectors comparative analysis. *Research Policy*, 30(7), 1139–1158.
10. Chersbrough, H. W. (2003). *Open innovation: the new imperative for creating and profiting from technology*. Boston, MA: Harvard Business School Press.
11. Clausen, T., Pohjola, M., Sapprasert, K., & Verspagen, B. (2012). Innovation strategies as a source of persistent innovation. *Industrial and Corporate Change*, 21(3), 553–585.
12. Cohen, W. M., & Klepper, S. (1996). Firm size and the nature of innovation within industries: the case of process and product R&D. *The Review of Economics and Statistics*, 78(2), 232–243.
13. Costa, J., Botelho, A. & Teixeira, A. A. C. (2018) Persistence in innovation and innovative behavior in unstable environments. *GEE*.
14. Costa, Joana and Teixeira, A.A.C. and Botelho, A. (2020) "Persistence in innovation and innovative behavior in unstable environments: evidence from a Moderate Innovator". *International Journal of Systematic Innovation*, 6(1).
15. Dosi, G. (1982). Technological paradigms and technological trajectories: A suggested interpretation of the determinants and directions of technical change. *Research Policy*, 11(3), 147–162.
16. Dosi, G. (1988). Sources, procedures, and microeconomic effects of innovation. *Journal of Economic Literature*, 26(3), 1120–1171.
17. Dosi, G., & Malerba, F. (1996). *Organization and strategy in the evolution of the enterprise*. London: Palgrave Macmillan UK.
18. Dostie, B. (2018). The impact of training on innovation. *ILR Review*, 71(1), 64–87.
19. Duguet, E., & Monjon, S. (2004). Is innovation persistent at the firm level? An econometric examination comparing the propensity score and regression methods. *SSRN Electronic Journal*, 106–112.

20. Filippetti, A. & Archibugi, D. (2011). Innovation in times of crisis: National Systems of Innovation, structure, and demand. *Research Policy*, 40, 179-192.
21. Flaig, G., & Stadler, M. (1994). Success breeds success. The dynamics of the innovation process. *Empirical Economics*, 19(1), 55–68.
22. Freeman, C. (1982). *The economics of industrial innovation*. London: Francis Pinter.
23. Frenz, M., & Prevezer, M. (2012). What can CIS data tell us about technological regimes and persistence of innovation? *Industry and Innovation*, 19(4), 285–306.
24. Gallego, J., Rubalcaba, L., & Hipp, C. (2013). Organizational innovation in small European firms: A multidimensional approach. *International Small Business Journal*, 31(5), 563–579.
25. Ganter, A., & Hecker, A. (2013). Persistence of innovation: discriminating between types of innovation and sources of state dependence. *Research Policy*, 42(8), 1431–1445.
26. Geroski, P. A., Van Reenen, J., & Walters, C. F. (1997). How persistently do firms innovate? *Research Policy*, 26(1), 33–48.
27. Gilbert, R. J., & Newbery, D. M. G. (1982). Preemptive patenting and the persistence of monopoly. *American Economic Review*, 72(3), 514–526.
28. Hecker, A., & Ganter, A. (2014). Path and past dependence of firm innovation. *Economics of Innovation and New Technology*, 23(5–6), 563–583.
29. Juliao-Rossi, J., & Schmutzler, J. (2016). Persistence in generating and adopting product innovations. *Academia Revista Latinoamericana de Administración*, 29(2), 125–146.
30. Kennedy, S., Whiteman, G., & van den Ende, J. (2017). Radical Innovation for sustainability: The power of strategy and open Innovation. *Long Range Planning*, 50(6), 712–725.
31. Lazzarotti, V., Manzini, R., Nosella, A., & Pellegrini, L. (2016). Collaborations with scientific partners: The mediating role of the social context in fostering innovation performance. *Creativity and Innovation Management*, 25(1), 142–156.
32. Le Bas, C., & Latham, W. (Eds.) (2006). *The economics of persistent innovation: An evolutionary view*. Berlin: Springer.
33. Le Bas, C., & Scellato, G. (2014). Firm innovation persistence: a fresh look at the frameworks of analysis. *Economics of Innovation and New Technology*, 23(5–6), 423–446.
34. Malerba, F., & Orsenigo, L. (1997). Technological regimes and sectoral patterns of innovative activities. *Industrial and Corporate Change*, 6(1), 83–118.
35. Malerba, F., Orsenigo, L., & Peretto, P. (1997). Persistence of innovative activities, sectoral patterns of innovation and international technological specialization. *International Journal of Industrial Organization*, 15(6), 801–826.
36. Máñez, J. A., Rochina-Barrachina, M. E., Sanchis, A., & Sanchis, J. A. (2009). The role of sunk costs in the decision to invest in R&D. *The Journal of Industrial Economics*, 57(4), 712–735.
37. Mansfield, E. (1968). *Industrial research and technological innovation: An econometric analysis*. New York: Cowles Foundation for Research in Economics at Yale University by Norton.
38. Marsili, O., & Verspagen, B. (2001). Technology and the dynamics of industrial structures: An empirical mapping of Dutch manufacturing. *Industrial and Corporate Change*, 11(4), 791–815.
39. Nelson, R. R., & Winter, S. G. (1983). *An evolutionary theory of economic change*. Cambridge, MA: Belknap Press of Harvard University Press.
40. OECD Eurostat. (2005). *Oslo Manual: Guidelines for collecting and interpreting innovation data - 3th edition (The Measurement of Scientific and Technological Activities)*. Paris: Organisation for Economic Cooperation and Development, Statistical Office of the European Communities.
41. Pavitt, K. (1984). Sectoral patterns of technical change: Towards a taxonomy and a theory. *Research Policy*, 13(6), 343–373.
42. Peters, B. (2009). Persistence of innovation: stylised facts and panel data evidence. *The Journal of Technology Transfer*, 34(2), 226–243.
43. Raymond, W., Mohnen, P., Palm, F., & van der Loeff, S. S. (2010). Persistence of innovation in Dutch manufacturing: Is it spurious? *Review of Economics and Statistics*, 92(3), 495–504.



44. Santos-Rodrigues, H., Dorrego, P. F., & Jardon, C. F. (2010). The influence of human capital on the innovativeness of firms. *International Business & Economics Research Journal (IBER)*, 9(9), 53–64.
45. Scellato, G., & Ughetto, E. (2010). The basel II reform and the provision of finance for R&D activities in SMEs:
46. An analysis of a sample of Italian companies. *International Small Business Journal*, 28(1), 65–89.
47. Schumpeter, J. (1942). *Capitalism, Socialism and Democracy*. New York, Harper and Brothers. Routledge.
48. Schumpeter, J. A. (1934). *The theory of economic development*. Cambridge: Harvard University Press.
49. Silva, E. G., & Teixeira, A. A. C. (2011). Does structure influence growth? A panel data econometric assessment of “relatively less developed” countries, 1979-2003. *Industrial and Corporate Change*, 20(2), 457–510.
50. Stoneman, P. (1983). *The economic analysis of the technical change*. Oxford: Oxford University Press.
51. Suárez, D. (2014). Persistence of innovation in unstable environments: Continuity and change in the firm’s innovative behavior. *Research Policy*, 43(4), 726–736.
52. Sutton, J. (1991). *Sunk costs and market structure*. Cambridge MA: The MIT Press.
53. Tavassoli, S., & Karlsson, C. (2015). Persistence of various types of innovation analyzed and explained. *Research Policy*, 44(10), 1887–1901.
54. Teece, D. J., Pisano, G., & Shuen, A. (1997). Dynamic capabilities and strategic management. *Strategic Management Journal*, 18(7), 509–533.
55. Teixeira, A. A. C., & Santos, L. C. B. (2016). Innovation performance in service companies and KIBS vis-à-vis manufacturing: the relevance of absorptive capacity and openness. *Review of Business Management*, 18(59), 43–66.
56. Triguero, Á., & Córcoles, D. (2013). Understanding innovation: An analysis of persistence for Spanish manufacturing firms. *Research Policy*, 42(2), 340–352.
57. Varis, M., & Littunen, H. (2010). Types of innovation, sources of information and performance in entrepreneurial SMEs. *European Journal of Innovation Management*, 13(2), 128–154.
58. Weitzman, M. L. (1998). Recombinant Growth. *Quarterly Journal of Economics*, 113(2), 331–360.
59. Winter, S. (1984). Schumpeterian competition in alternative technological regimes. *Journal of Economic Behavior and Organization*, 5(3–4), 287–320.

## APPENDIX 1

### Variable Description

Variable	Type	Description
<b>Acapacity</b>	Count	Counts for the number of R&D types that firm uses
<b>Internal Balance</b>	Binary	1 if the firm use R&D extern and training
<b>Education_intensity</b>	Count	Ratio comparing the number of top educated workers to the total
<b>Openness</b>	Count	Counts for the number of sources of innovation the firm uses
<b>Funds</b>	Binary	1 if the firm uses public funds
<b>Medium_size</b>	Binary	1 if the firm in medium
<b>Large_size</b>	Binary	1 if the firm in large
<b>Group</b>	Binary	1 if the firm belongs to an economic group
<b>Industry</b>	Binary	1 if the firm belongs to the industrial sector
<b>Services</b>	Binary	1 if the firm belongs to the services sector

# INTERDEPENDENCE OF CREDIT LENDING TO THE PRIVATE SECTOR AND THE GDP GROWTH RATE IN THE REPUBLIC OF CROATIA

**Marko Akmacic**

*Libertas International University, Trg J.F.Kennedya 6b, Croatia  
marko.akmacic@icloud.com; makmacic@libertas.hr*

**Andreja Rudancic**

*Libertas International University, Trg J.F.Kennedya 6b, Croatia  
arudancic@hotmail.com; arudancic@libertas.hr*

**Vesna Skare Ozbolt**

*Attorney at Law, Zagreb, Croatia  
vesna.skareozbolt@gmail.com*

## ABSTRACT

*This paper, in its main section, empirically investigates and determines the characteristics and factors of credit lending and GDP and the correlation between private-sector lending and economic growth in the Republic of Croatia. The aim of this paper is derived from the main section, which is to identify and prove connections and interdependence between credit lending and economic growth in the Republic of Croatia. Therefore, this paper aims to provide a better understanding of how private sector lending affects economic growth and GDP growth. Namely, if quality loans with low-interest rates are provided to the economy, they will stimulate economic growth. In contrast, if there are no available loans, lower rates of economic growth and a decline in employment rates will occur. Based on the above, the following hypothesis of this paper was established as the starting point of the research, which reads: "There is a close positive relationship between private-sector lending and GDP growth rate." The methodology used in the paper consists of the basic methods of descriptive and inferential statistics, which have been applied to prove or disprove correlations between individual variables. The relevant statistical programs IBM SPSS Statistics 22 and MS Excel were used for analysis and presentation. It is therefore concluded that despite the existence of a tight positive link between private sector loans growth and GDP growth, there is a lack of linearity between them, which precludes any possibility of above confidence forecast of 79.3%, which is not sufficient for further research.*

**Keywords:** *economic growth, lending, private sector, GDP, Republic of Croatia*

## 1. INTRODUCTION

The study of monetary aggregates raises several different questions, ranging from what is covered by a single monetary aggregate, to what are the causes of their fluctuations and what is their overall impact on employment rates and GDP growth. For the normal functioning of an economic entity, it is necessary to achieve a certain degree of money supply, and any disturbance in the cash flow will be reflected in the real economic trends. Money stock, exchange rate and interest can improve or worsen the situation in the society in general through the operation of the monetary mechanism. Namely, if quality loans with low-interest rates are provided to the economy, they will stimulate economic growth. In contrast, if there is no lending, lower rates of economic growth and a decline in employment rates will occur. The banking system exerts influence on the growth of the economy in quantitative terms by increasing or decreasing the private sector lending rate. This paper aims to research, consistently identify and explain all the relevant, theoretical features and factors of individual

monetary aggregates and how they correlate with GDP, lending and economic growth in the Republic of Croatia. By applying the historical method, the inductive and deductive approaches, the method of abstraction and concretization, as well as the method of generalization and specialization, the individual monetary aggregates, GDP and crediting will be presented. The research will cover the analysis of the interdependence of private-sector lending and economic growth from 2007 to 2018 in the Republic of Croatia, and it will analyse the data provided by the Croatian National Bank and the Central Bureau of Statistics. In preparation, formulation and presentation of the research for this paper, a combination of numerous scientific methods will be applied.

## **2. MONETARY AGGREGATES AS INDICATORS OF LIQUIDITY**

Monetary aggregates are a group of financial instruments of the same degree of liquidity. Monetary aggregates are combinations of different elements that are part of the money supply. The composition of the monetary aggregate determines its effectiveness, and the structure of the monetary aggregate depends on the institutional and financial structure of the economy. According to the Act on the Croatian National Bank (Official Gazette 54/13), a bank can only create primary money, but in practice, the CNB can fully control only that part of the primary money resulting from open market operations and the purchase of foreign exchange. Its control is limited as other institutions can issue money in the form of loans (commercial banks, savings banks) or bonds (state, local self-government). The money supply depends mainly on the economic variables that can be measured (interest rate, size of income, etc.), but also on the behaviour of economic operators who display different preferences and different responses, thus restructuring their property portfolios. Therefore, the money supply depends on the number of free bank funds and cash that the non-banking sector wants to have (Lovrinović & Ivanov, 2009:124).

## **3. FLUCTUATION DYNAMICS OF THE REPUBLIC OF CROATIA'S MONETARY AGGREGATES**

The analysis of monetary aggregates in the Republic of Croatia is presented following the methodology and published data of the Croatian National Bank. The subjects of analysis are primary money, money supply, total liquid assets and net domestic assets. The structure of individual aggregates and the dynamics of their fluctuations in the period from 2000 to 2018 are discussed. The above graph shows the fluctuation dynamics of selected and observed monetary aggregates of the Republic of Croatia over eighteen years, i.e. during a period in which changes related to external factors (global financial crisis) and internal events (numerous reforms that were more or less successful) are recorded in the Croatian monetary and economic system, along with a stable HRK (kuna) exchange rate and controlled inflation. In this context, it can be concluded that total liquid assets recorded constant growth throughout the entire observed period. The fluctuations in both 2008 and 2009 were noticeably affected by the crisis, but they had a greater impact on primary money and money supply, and partly on the net domestic assets.

*Chart following on the next page*

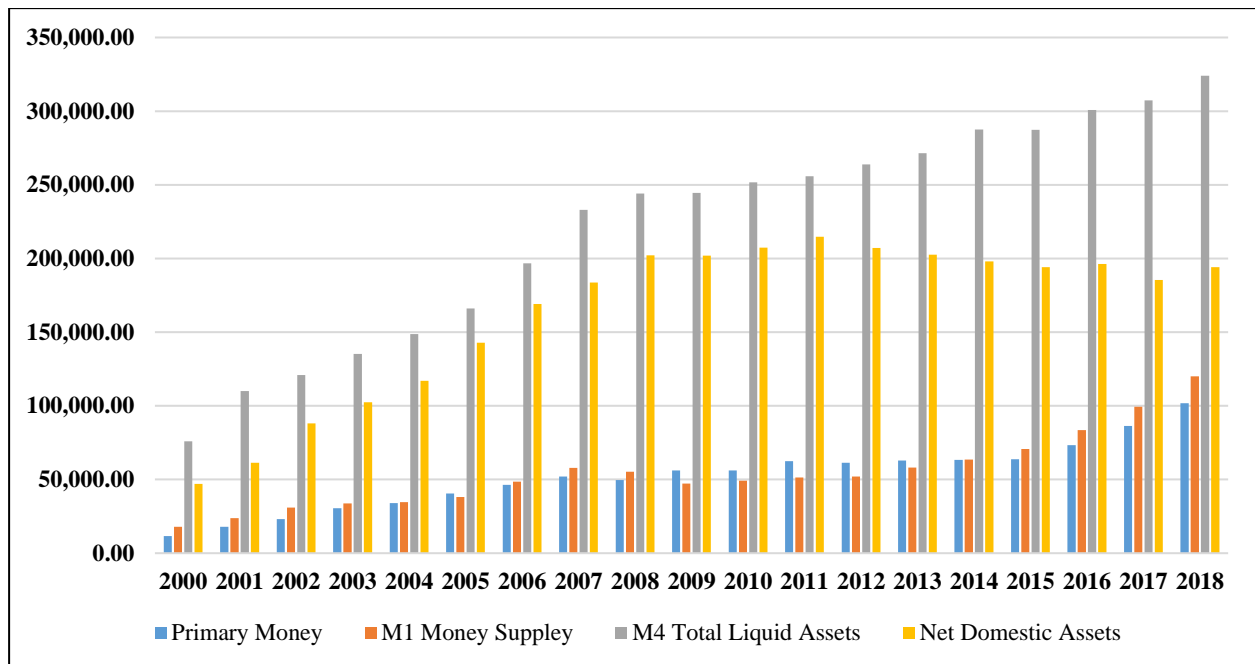

*Chart 1. Comparison of monetary aggregate fluctuations in the Republic of Croatia from 2000 to 2018*

(Source: MS Excel processing according to CNB statistical datasheets, Croatian National Bank, Monetary and Credit Aggregates, <https://www.hnb.hr/statistika/statisticki-podaci/finansionalni-sektor/monetarni-i-kreditni-agregati>, reviewed on 20 March 2020)

The above indicates the atypical fluctuation of NDA aggregates resulting from the increase in NDI aggregates, as total liquid assets are constantly growing.

### 3.1. The Concept and the Role of Credit Loans

Credit loans are a group of active banking businesses. The term credit comes from the Latin word *credo*, which means I believe. A loan can be defined as the ability to obtain ownership and receive goods for use in the present, while payment for those goods is deferred to some date in the future. The main feature of the loan is the obligation to repay it, i.e. the obligation of the borrower to take the loan after the expiration of the period for which the loan agreement was concluded, repay the approved loan amount with the loan. The cost of a loan is expressed in the amount of the interest rate, which depends on the duration of the loan, the riskiness of the loan business, the cost of obtaining the necessary funds for loan approval (Miller & VanHoose, 1993:79). Credit loan also has an important controlling role in the economy. The most important form of control is exercised by the central bank, which affects the credit placements of the banks through the system of monetary and credit policy instruments, and thus directly affects the operations of the borrowing companies. Loan repayment issues that can occur with the borrower can also be a form of the loan's controlling function as they may indicate some of the problems in the economy. Loan placements are classified according to various criteria: the loan's maturity, goal, subject-matter in which it needs to be settled, the entities to which the loan is granted, the purpose, domicile of the loan provider and the mode of securing the loan (Katunarić, 1988: 251).

#### 4. CIRCUMSTANCES AND STRUCTURE OF PERSONAL LOAN PLACEMENT IN THE REPUBLIC OF CROATIA

The household sector is composed of a large number of households that can be classified according to the current income criterion and the property criterion. From a cash flow perspective, total household sector revenues are allocated to current spending expenditures, government payables, savings which can be used in two ways: to increase tangible assets or to increase financial assets. Banks, as independent financial institutions whose business objective is to receive cash deposits, to provide loans and other placements in the performance of its activities specified by the Act on Banks, form an integral part of the financial system. Personal loans include the following groups of credit placements: non-purpose cash loans, credit card loans, car purchase loans, housing loans, mortgage loans and other loans such as short-term current account loans, travel loans, loans for equipping tourism/hotel facilities, etc. (Babić, 1996: 23-54). The following graph shows the distribution of personal loans, taking into consideration that the personal loans category in the statistical reports of the Croatian National Bank and the Central Bureau of Statistics since 2010 has been harmonized with the European System of National and Regional Accounts 2010 (ESA 2010), which under the term "personal" includes both households and non-profit institutions serving households. The data systematized in Chart 2 present the structure of personal loans provided by banks as of December 31, 2018.

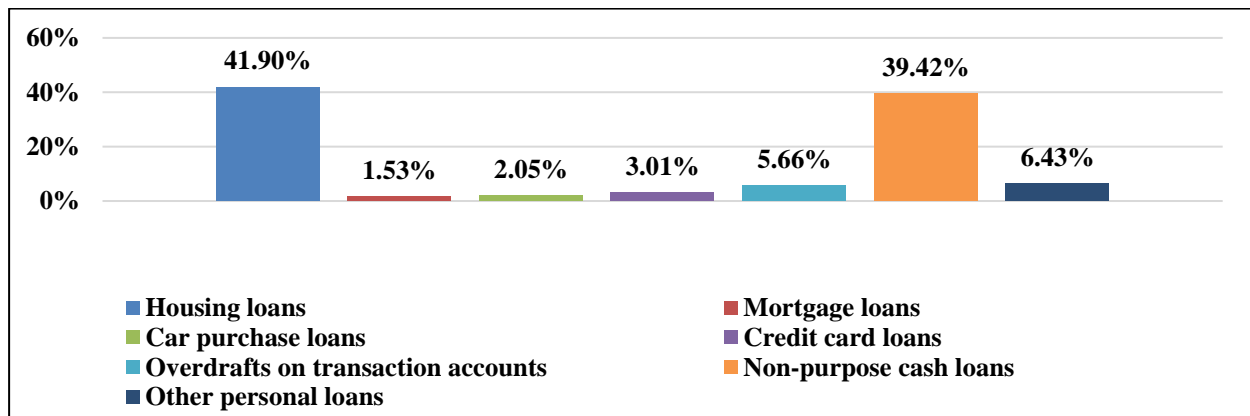

*Chart 2. Structure of personal loans provided by banks (December 31, 2018)  
(Source: Bank Bulletin 32. Zagreb: Croatian National Bank)*

As can be seen from the above chart, two types of retail lending/personal loans stand out according to the size of the loans, namely housing loans and non-purpose cash loans, which together account for more than two-thirds of total retail loans. Housing loans are virtually a driver of banks' lending activity, as most other loans are tied to them. Namely, non-purpose cash loans are mainly used for furnishing residential premises, which includes credit card loans. In terms of currency, the Croatian National Bank monitors loan placements in both kuna and foreign currency and cumulatively in kuna translated at the CNB middle exchange rate for the observed period. The dynamics of household loans in relation to housing loans for the period 2007 to 2018 regarding the loan currency is presented in the following chart.

*Chart following on the next page*

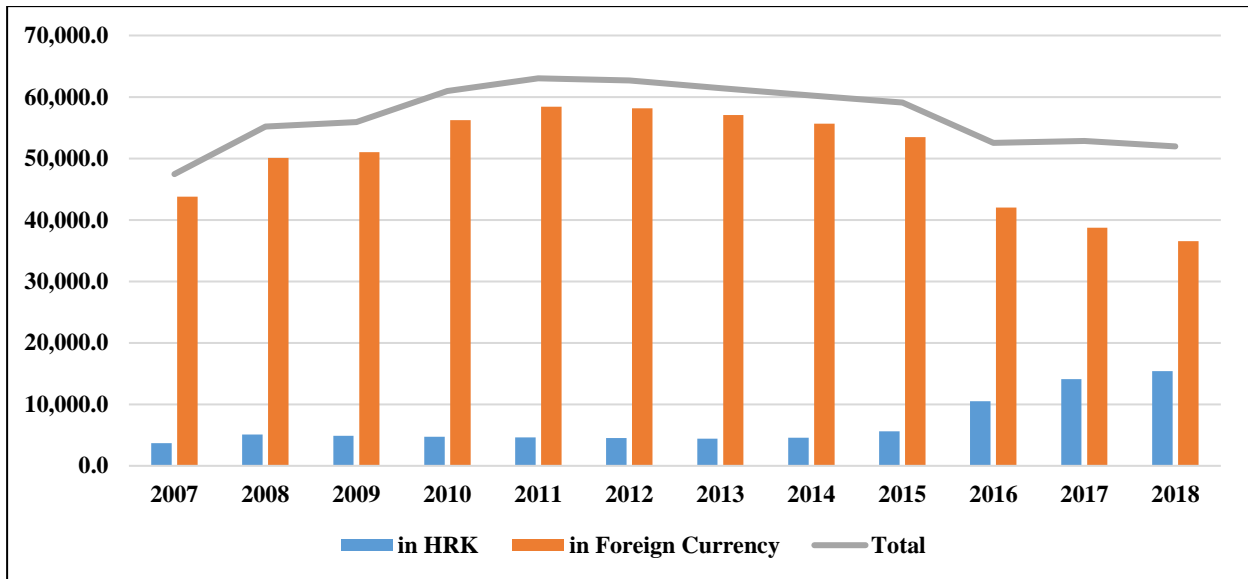

*Chart 3. Dynamics of Housing Loans by Currency (End of the period in HRK million)  
(Source: Extrapolated according to the Croatian National Bank's data)*

Housing loans in the total banks' placement towards households participated in the observed period from a share of 41% at the end of 2007 to 48% in the period from 2011 to the end of 2014. This was followed by a gradual decline which was stabilised in 2017 at 44%. When looking at the ratio of approved housing loans in kuna and those in foreign currency, it is noticeable that at the beginning of the observed period (2007-2015), this ratio was 8: 92, which has significantly changed in 2016 and amounted to 20: 80. In 2017, it reached a ratio of 27: 73 in favour of foreign currency loans. Certainly, the most significant banks' retail lending events were recorded after the conversion of loans into euros and kuna, which has affected the banks' operations and, consequently, their credit placements.

## **5. CIRCUMSTANCES AND STRUCTURE OF LOAN PLACEMENTS TO NON-FINANCIAL ENTERPRISES IN THE REPUBLIC OF CROATIA**

The private sector includes companies owned by private individuals and subsequently funded and run by them. The goal of private sector companies is profit. This sector is responsible for allocating most of the resources within the economy and basically, it is the driver of the entire national economy. Private sector enterprises can be small enterprises with only one owner, or large multinational companies operating worldwide (Bakotić & Bušić, 2014: 222-240). However, the private sector is not unambiguously statistically defined, resulting in possible disagreements when presenting data. Namely, according to the sector classification of institutional units of the Central Bureau of Statistics of the Republic of Croatia, the private sector is classified as non-financial corporations that are nationally private (S11002) and foreign-controlled (S11003). Under the aforementioned classification, the Croatian National Bank also keeps statistics of other monetary financial institutions (DMFI) and commercial banks that lend to private enterprises in kuna or foreign currency. The dynamics of private companies' demand for credit loans follow the money market trends, levels of interest rates, creditworthiness of credit seekers, general social and political situation in the country and its environment, stability of national and European currency exchange rates and other factors.

Expectations that after the impact of the global financial and economic crisis and recovery from 2009 to 2014, credit demand will increase, have not been realised despite the stability of the exchange rate, the abolition of the currency clause and low-interest rates.

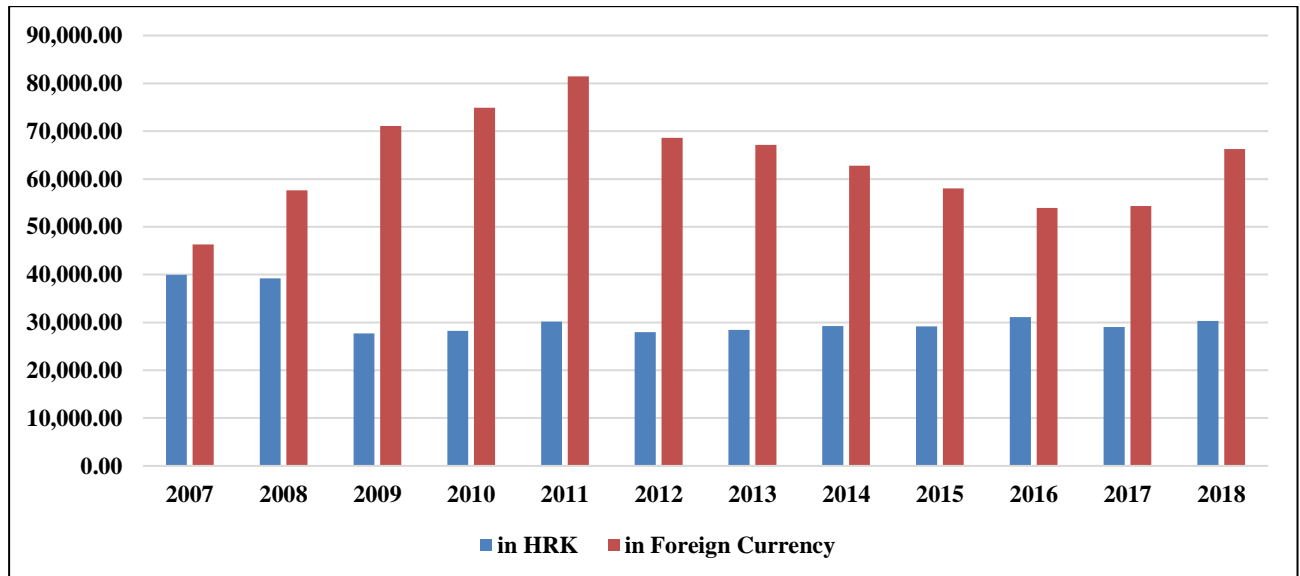

*Chart 4. Dynamics of loan fluctuations in the non-financial sector by currency (in HRK million at the end of the period)*

*(Source: Extrapolated according to the Croatian National Bank's data)*

Chart 4 shows that the spread between the kuna and foreign currency loans after 2007 has been increasing ever since and gradually decreasing after recovery from the 2014 crisis. Kuna loans, which recorded a decline in 2009, maintained this volume until the end of the observed period. In contrast, foreign currency loans peaked in 2011, followed by a downward trend until 2017. In addition to the currency structure, it is also possible to analyse the structure of loans to non-financial corporations and according to the activities they perform. Chart 4 shows that the share of loans to non-financial corporations in the total credit portfolio of commercial banks has been steadily declining since the 2011 crisis. The reasons should be sought in the problems of the manufacturing industry, that is, large state-owned systems to which the private sector is tied, but also in the increasing use of non-refundable EU funds. The following chart shows the structure of approved loans to non-financial corporations at the end of 2018 by activities.

*Chart following on the next page*

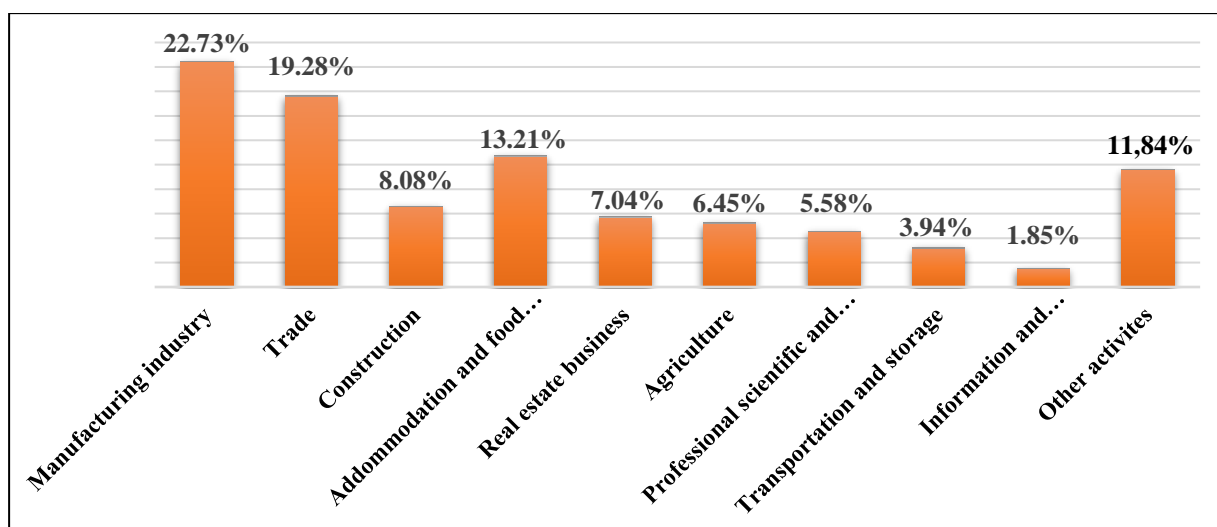

Chart 5. Structure of bank loans to non-financial corporations by activities (31 December 2018) (Source: CNB. 2018. Bulletin on Banks 32. Zagreb: Croatian National Bank)

In the non-financial corporations' sector, banks have been increasingly lending to tourism and professional, scientific and technical activities. Gross loans to non-financial corporations in 2016 decreased by 3.9 billion Kuna or 4,5% compared to the previous year (2015). Chart 5 shows that manufacturing and trade were the most credited. This is likely consistent with the capital turnover ratios in such industries. Construction and agriculture generally retain positions throughout the post-crisis period.

Tourism is not statistically presented on its own, but its impact is visible directly through the activities of accommodation and food preparation, trade, transport, and indirectly through all others.

## 6. ANALYSIS OF THE STRUCTURE OF THE GROSS DOMESTIC PRODUCT OF THE REPUBLIC OF CROATIA

Economic results according to Eurostat Statistic Explained 2018. Eurostat can make a large initial analysis of the following activities: agriculture, forestry and fishing; industry; construction equipment; trade, transportation, accommodation and catering services; information and communication services; financial and insurance services; real estate business, professional, scientific, technical; administrative and support service activities; public administration, defense, education, health and social work; arts, entertainment, recreation, other services and activities of households and extra-territorial organizations and bodies.

Data on the main aggregates of GDP are collected from institutional units, that is, non-financial or financial companies, general government, households and non-profit institutions serving households. Data within national accounts include data on GDP components, employment, final consumption aggregates and savings. These variables are calculated on an annual and quarterly basis. The following table shows the dynamics of GDP of the Republic of Croatia according to the current price expenditure approach. The expenditure method, according to the calculation methodology of the Central Bureau of Statistics, includes (Methodological Instructions 2018): consumption by households and non-profit institutions serving households and government consumption, gross investment and the difference in exports and imports of goods and services.



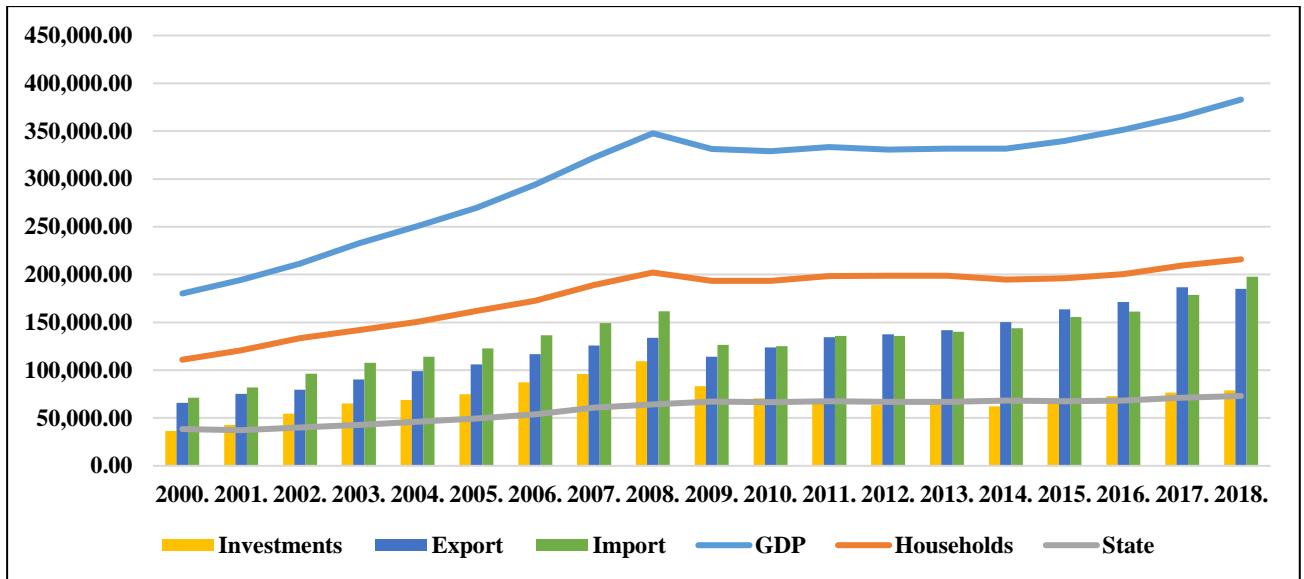

Chart 6. Dynamics of GDP of the Republic of Croatia according to the Current Price Expenditure Method - (End of the period in HRK million)  
(Source: CBS, Gross Domestic Product, Expenditure Method)

It is possible to analyze the structure of GDP in terms of consumption from Chart 6. This method suggests that consumption is a major driver of economic development. The consumption of households and non-profit institutions serving households should be differentiated from the spending of state institutions and administration. Namely, the consumption of the population is related to the creation of added value, while the consumption of the state is mostly the cost. The chart also shows the importance of the scale of exports and imports of goods since imports reduce the value of GDP.

## 7. ANALYSIS OF THE GROWTH TRENDS OF THE REPUBLIC OF CROATIA'S GROSS DOMESTIC PRODUCT

GDP trends in the Republic of Croatia are an important indicator that should be viewed within the context of the long crisis period and the more pronounced growth that followed in 2016 and 2017, the required growth rates and sources of this growth and the relatively poor position relative to European Union average. The period from the end of the war in 1995 to 2008, that is, the beginning of the “spillover” of the global financial and economic crisis, was marked in the Republic of Croatia by the steady growth of the economy. However, this growth was insufficient when compared to other transition countries, and in particular to the EU Member States. Thus, according to the Croatian Chamber of Economy data, growth of the Republic of Croatia's GDP for the period 1996-2008 (1995 as the base year) was 65.5%, while the average growth in the EU10 Member States was 82% (Croatian Chamber of Economy, GDP Trends in the Republic of Croatia - Sources of Growth and Consequences, 2017). The period from 2000 to 2008 is characterized by significant GDP growth, with an average growth rate of 4.2%, which is linked to investments in fixed capital and infrastructure (highway construction). The global crisis had an impact on economic growth from 2009 to 2014, which resulted in a halt to capital flows. The crisis has caused a decline in real GDP or a 12.6% decrease in the level of economic activity that was measured by real GDP. The recovery took place in 2015 and continued in 2016 and 2017 with the good prospect of continuing positive developments. The Republic of Croatia has a high share of tourism in GDP, which varies between 18 and 19%, which is among the highest in the European Union.

Due to the high share of tourism in total GDP, seasonal fluctuations are very evident, reaching a maximum in the third quarter, and a minimum in the first one as shown in the following chart (Croatian Chamber of Economy, GDP Trends in Croatia - Sources of Growth and Consequences, 2017 ).

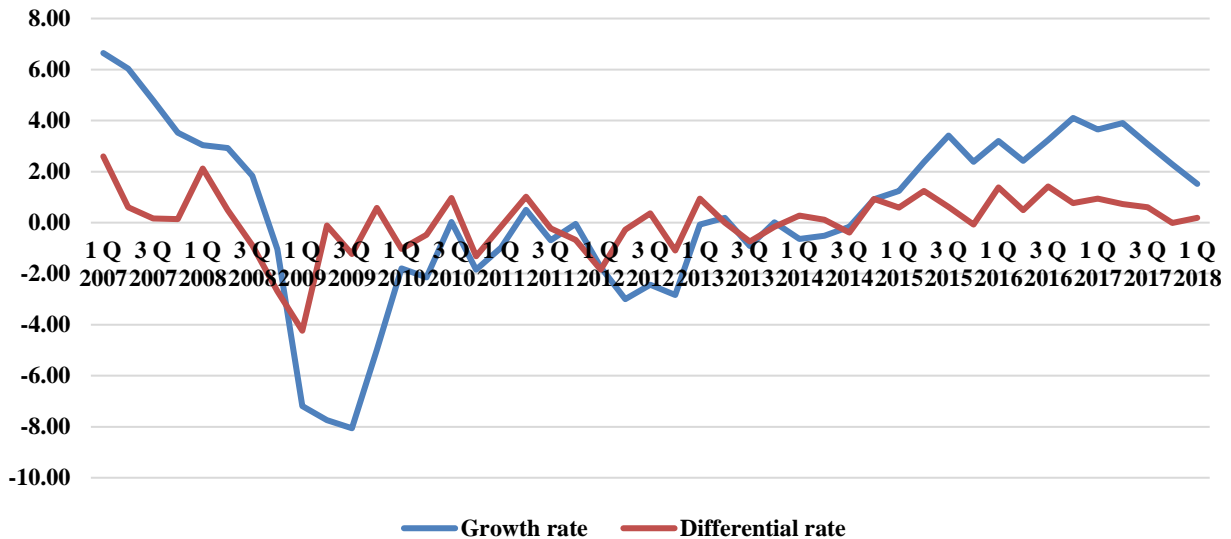

Chart 8. Quarterly Trends in GDP Growth Rates and Quarterly Trends in GDP Rate Differences for the period 1-2007 to 1-2018 (in%)  
(Source: CBS, Gross Domestic Product, Seasonally Adjusted Rates)

Chart 8 shows clearly how the crisis has affected the Croatian economy and how long the recovery process has been, and how slight disruptions in the European and world markets impact the growth of the Croatian economy. It can be concluded that the Croatian economy is highly dependent on the success of the tourist season and the political and economic stability of the immediate and wider environment. Although some periods are marked by more dynamic growth, made possible by the previous low level of economic activity and favourable circumstances in the global environment, when the strength of the Croatian economy is compared with the countries of comparable characteristics in the environment, then a slow growth of GDP is more visible.

## 8. EMPIRICAL RESEARCH ON THE CAUSALITY BETWEEN THE PRIVATE SECTOR CREDITING AND GDP GROWTH IN THE REPUBLIC OF CROATIA

The issue of the link between the financial and real sectors has long been of interest to economists, and many of them indeed confirm the positive link between financial development and economic growth. However, as stated by Stipković and Bogdan, there is an increasing number of papers showing that with financial development this link is weakened or even becomes negative (Stipković & Bogdan, 2017; 179-204). In order to confirm, or refute, the hypotheses of this paper on the strong correlation between the real GDP growth in the Republic of Croatia, the relatively strong interdependence of economic growth and the correlation between the private sector lending and GDP growth, it was necessary, in addition to the previous points elaborating on the theoretical proofs, to carry out the empirical verification. The empirical research, the hypotheses of the established links, has been reduced to the collection and processing of numerous data and indicators published by relevant sources such as the Croatian Central Bureau of Statistics, the Croatian National Bank, the Croatian Employment Service and of reports issued by the commercial banks based in the Republic of Croatia. The problem noted in this part of the research relates to the inconsistency of published reports

concerning time series, frequent changes in reporting methodology related to Eurostat compliance, which required additional interpolations to make the data acceptable for comparison and statistical processing. The basic indicators of the research topic were analysed in the previous chapters: monetary aggregates, loans to the private sector and gross domestic product in the Republic of Croatia. In that process, static and dynamic data from different sources were analysed and presented according to thematic areas. Different time series were also used (monthly, quarterly, annually) for periods of 26 years, 18 years, 11 years, eight years and three years depending on the subject of the research. However, to use these indicators in an empirical study of their correlation and interdependence (regression analysis), all data must be harmonised and the time series unique.

Therefore, according to the research topic, a 12-year period is taken as the reference period, given that it contains pre-crisis periods (2007), crisis period (2008-2009), recovery period (2010-2014) and the post-crisis period (2016 - 2018). This would provide a realistic time series in years with values on December 31 of the current year. All indicators are translated into real growth rates at that date of the current year, with the initial year being 2006. The following table shows the values of the indicators.

YEAR	PERSONAL LOANS GROWTH RATE	PRIVATE SECTOR LOANS RATE	GDP GROWTH RATE
2007	9,21	10,22	9,63
2008	13,52	12,27	7,84
2009	-1,50	1,95	-4,71
2010	5,14	4,46	-,67
2011	1,78	8,24	1,31
2012	-1,12	-13,49	-,79
2013	-1,82	-1,04	,29
2014	-1,17	-3,71	-,06
2015	-1,66	-5,21	2,43
2016	-7,32	-2,52	3,45
2017	1,02	-1,90	4,07
2018	4,0	-0,80	2,06

*Table 1. Annual growth rates of selected macroeconomic indicators from 2007 to 2018 (end of period)*

*(Source: CBS, CNB, CES data)*

The calculated growth rates of the selected macroeconomic indicators are analysed below in accordance with the research hypothesis. This paper will prove the assumption of the interdependence of bank loans and economic growth in the Republic of Croatia. The study will cover the analysis for the period 2007 to 2018 in the Republic of Croatia. Research on the link between private sector lending and GDP growth rates is limited to the structure of available data on lending to the non-financial sector issued by commercial banks in the Republic of Croatia.

Namely, the private sector is not clearly defined by the methodology for publishing data in private sector financing, either for investment or working capital. The unspecified area is left when it comes to lending to private financial corporations (insurance companies, credit unions, currency exchange offices, leasing companies, factoring companies, etc.) because their business is also related to the provision of services and thus the population's consumption.

PEARSON'S CORRELATION (NOMINAL)		
VARIABLE	<i>u</i> LOANS	<i>u</i> GDP
<i>u</i> LOANS	1	0,504
N		11
Significance		0,114
Mean value		2,0718
Standard deviation		4,07945
<i>u</i> GDP	0,504	1
N	11	
Significance	0,114	
Mean value	0,8427	
Standard deviation	7,5677	
KENDALL T CORRELATION (ORDINAL)		
VARIABLE	<i>u</i> KREDITI	<i>u</i> GDP
<i>u</i> LOANS	1	0,309
N		11
Significance		0,186
<i>u</i> GDP	0,309	1
N	11	
Significance	0,186	
SDPERMAN $\rho$ CORRELATION (ORDINAL)		
VARIJABLA	<i>u</i> LOANS	<i>u</i> GDP
<i>u</i> LOANS	1	0,400
N		11
Significance		0,223
<i>u</i> GDP	0,400	1
N	11	

Table 2. Correlations of *u*CREDIT and *u*GDP variables

The values of the correlation coefficients indicate that there is a weak positive relationship between the observed variables, i.e. how the increase in GDP growth rate affects the growth rate of credit loans to the private sector. The high standard deviation value indicates a wide range of values reached by the growth rates over the observed period. Correlation analysis also indicates that the increase in credit loans to the private sector should moderately influence the increase in GDP, which is not necessary given the large share of working capital loans, that does not affect the production and export component of the GDP structure. In the regression analysis model, the dependent variable is *je u*LOANS while the predictors or independent variables are *u*GDP, *u*M<sub>1</sub> and *u*Employed.

Model Summary<sup>b</sup>

Model	R	R Square	Adjusted R Square	Std. Error of the Estimate	Change Statistics					Durbin-Watson
					R Square Change	F Change	df1	df2	Sig. F Change	
1	,677 <sup>a</sup>	,458	,226	6,65946	,458	1,971	3	7	,207	2,352

a. Predictors: (Constant), *u*ZAPOSLENOST, *u*M1, *u*BDP

b. Dependent Variable: *u*KREDITIPOD

Model 1. Regression analysis

It is evident from the descriptive table that the correlation coefficient (R) of the predictor is 0.677, suggesting a medium-strong relationship. The coefficient of determination ( $R^2$ ) is 0.458 and represents a square deviation of the correlation coefficient and shows that this study has explained 54.2% of the variables, while the other 45.8% was influenced by others (unknown factors for this study). F is 1,971, suggesting that there is no significant difference in the variance deviations between the dependent and independent variables. The value of the Durbin-Watson test indicates the representativeness of the regression model.

Model 3		Sum of Squares	df	Mean Square	F	Sig.
1	Regression	262,272	3	87,424	1,971	,207 <sup>b</sup>
	Residual	310,439	7	44,348		
	Total	572,711	10			

a. Dependent Variable: uKREDITIPOD

b. Predictors: (Constant), uZAPOSLENOST, uM1, uGDP

#### *Model 2. ANOVA*

Given that statistical significance for all predictors has a Sig value = 0.207 which is  $> 0.05$ , which means that the forecasting conditions are not valid but are in the area of random guessing. It can be concluded that despite the existence of a moderately strong link between private sector credit growth and GDP growth, there is a lack of linearity between them which precludes any possibility of forecasting above confidence of 79.3%, which is not sufficient for further research. This also confirms the hypothesis of the H1 survey on the existence of a close link between private sector credit growth and GDP growth.

## **9. CONCLUSION**

The Republic of Croatia belongs to the group of transition countries with particularities related to separation from the former country union, war events, international isolation and transition of the political and economic system. All these developments have reflected on the economic growth and GDP as its measure. The transition to a market economy has led to an expected fall in employment rates which, due to the above, has not been cancelled out by the expected results of private entrepreneurship. In contrast, a stagnation occurred, mainly due to the sluggishness of the state apparatus, i.e. the lack of reforms that would accelerate the transition to a market economy. Private entrepreneurship lending was envisioned as a driver of private sector development, but after a negative episode with Swiss Franc loans, a slowdown in lending activities followed. By pegging the Kuna exchange rate to the Deutsche Mark and then to the Euro, the CNB indirectly influenced the money supply in circulation. This led to a relatively weak correlation between the observed aggregates, which is unusual in the economies of developed countries. The large range of observed variables as well as the oscillations and the extremely strong seasonal influence in the observed time periods were reflected by the high value of standard deviation, variance, scatter, and nonlinearity. The interdependence of bank credit loans and economic growth in the Republic of Croatia functions to the extent permitted by the degrees of freedom of action of the monetary market, commodity market, and thus of the labour market of the Republic of Croatia. A close positive relationship between private sector lending growth and GDP growth was confirmed. The existence of a weak link can be explained by the reduced demand for private-sector loans due to the impact of the crisis and reduced entrepreneurial activity, but there are certainly other factors such as direct investments, use of EU funds, government incentives and other forms of financing.

However, given that gross domestic product growth directly affects all forms of household savings and corporate deposits, which ultimately means deposit money increase in commercial bank accounts, it can be expected that credit institutions will change their lending policies. Since the price of money is at an acceptable level, it can be expected that financial monitoring of the ongoing operations and development of private companies will increase, especially of those that produce goods and services for both the domestic and the foreign market.

#### LITERATURE:

1. Babić, A. (1996). *Mikroekonomska analiza banaka i struktura bankovnog tržišta u Hrvatskoj*, Privredna kretanja i ekonomska politika 6 (48): 23-54.
2. Bakotić, D. i Bušić, J. (2014). *Organizacijska predanost zaposlenika u hrvatskim poduzećima: privatni sektor vs. javni sektor*, Ekonomski pregled 222-240.
3. Državni zavod za statistiku [Online] dostupno na: <https://www.dzs.hr/>
4. Državni zavod za statistiku Republike Hrvatske (2018) *Sektorska klasifikacija institucionalnih jedinica*, Zagreb
5. Eurostat – Statistics Explained [Online] dostupno na: [https://ec.europa.eu/eurostat/statistics-explained/index.php/Main\\_Page](https://ec.europa.eu/eurostat/statistics-explained/index.php/Main_Page)
6. Hrvatska gospodarska komora (2017), *Kretanje BDP-a u Hrvaskoj - izvori rasta i posljedice* [Online] dostupno na <https://www.hgk.hr/>
7. Hrvatska narodna banka (2018), *Bilten o bankama 32*, [Online] dostupno na <https://www.hnb.hr/analize-i-publikacije/redovne-publikacije/bilten-o-bankama>
8. Katunarić, A. (1988). *Principi i praksa bankovnog poslovanja*, Zagreb: CIP, str.251
9. Miller, R. I. i VanHoose, D. D. (1993). *Moderni novac i bankarstvo*, Zagreb: Mate, str.79
10. Stipković, P. i Bogdan, Ž. (2017). *Pokazatelji hrvatskog bankovnog sustava i gospodarski rast*, Zbornik Ekonomskog fakulteta u Zagrebu 15 (2): 179-204.,
11. Zakon o Hrvatskoj narodnoj banci (NN 54/13) [Online], dostupno na: <https://www.zakon.hr/z/590/Zakon-o-Hrvatskoj-narodnoj-banci>

# TOWARDS AN INCLUSIVE AND INNOVATIVE BIOENERGY DEVELOPMENT THROUGH BRAZILIAN AND NORDIC EXPERIENCE IN BIOFUELS

**Carlo Alessandro Castellanelli**

*University of Aveiro - DCSPT/GOVCOPP, Portugal*

*Ku Leuven, Belgium*

*carlo.castellanelli@ua.pt*

**David Nunes Resende**

*University of Aveiro - ESTGA/GOVCOPP, Portugal*

## **ABSTRACT**

*The expansion of the bioeconomy, with particular attention to biomass as a raw material for energy production, is inevitable due to the limits of nonrenewable resources. In this context, the development of bioenergy is often assumed to follow a uniform path. However, the design, organization, and policy tools that support the production of bioenergy in specific regional and local contexts may be the key to its full realization. Brazil is one of the pioneer countries in the production of biofuels and still maintains itself as one of the world's leaders, however, some recent issues in its production chain, more specifically regarding social exclusion and the interplay between involved actors, have been identified. The Nordic countries, on the other hand, despite having a more recent experience in biofuels, are pioneering with their innovative and inclusive bioenergy-led value chains, through initiatives such as the Smart Specialization Strategy (RIS3) - under the vision of a smart and sustainable Europe. Based on this, two case studies of biofuels development with potential for transformation of regional economies were studied. Our main focus in this paper was to analyze ways in which the bioeconomy and, in particular, the development of biofuels in the studied regions can create opportunities and promote cooperation / coordination between value chains, identifying their enabling and constraining factors with the intention of filling the gaps in these two realities that have been studied separately until now.*

**Keywords:** *Bioenergy, Biofuels, Regional Development, Brazil, Sweden, Regional Innovation Systems*

## **1. INTRODUCTION**

The oil crisis, triggered in the 1970s, has raised concerns about energy dependence in the western world. In addition, oil reserves instability, rising greenhouse gas emissions and consequent climate change (e.g global warming and desertification) have created a growing demand for renewable energy. In this context, nations are facing new challenges in the development of new energy sources<sup>1</sup> with technological researches that seek to obtain sources of renewable fuels and the reversal of global warming of the planet. One of the sources, which has been highlighted, is the use of biomass for energy purposes, mainly for use as transport fuel, generating the so-called biofuels. In this scenario, the nature and practices of global governance are changing, including those relating to governance of large-scale environmental issues. Sachs (2004), recognizes the importance of this interaction towards a biocivilization or a modern civilization of biomass given the social, environmental and economic issues in the world in recent years. In its analysis, the new civilization should follow a development model based on the biomass production chain, where new generations of biotechnologies would occupy an increasingly important place. Following this idea, bioenergy represents a golden

---

<sup>1</sup> Recently new energy sources are encouraged to be in accordance with the paradigm of economic, social and environmental sustainability.

opportunity to rethink rural development, not just to meet the demand for biofuels for transport. Renewable energies, and especially bioenergy, are seen as promising options for dealing with climate change/energy security and have recently undergone an important role linked to the situation and dynamics of the rural world, which can benefit from other possibilities for alternative development compared to the traditional, predominantly productivist agrarian model. Cavicchi (2014) stated that renewable energy and rural development have become two main priorities under political focus, almost all over the western world. It happened because the problem of energy supply is today a critical one, while rural areas contain most of the alternative and renewable energy resources of biomaterials, wind and water and yet have been experiencing a depopulation phenomenon and difficult economic crisis for several years. Yet, according to the OECD (2012), recent economic crises have necessarily linked the development of renewable energies to regional and rural development leading policy makers and researchers to develop or at least try to develop strategies for the production of renewable energies in rural regions including job creation, R&D and innovation. Under the thoughts of Edquist (2004), Foray et al. (2009), and Lundvall (2005), in rural areas, where the greatest benefits of renewable energy are observed, there is a recognizable regional innovation system around the renewable energy supply and distribution chain, which is unique for each region (CAVICCHI, 2014). The occurrence of favorable social and economic indicators of rural regions are usually linked to an explanatory factor such as location or other competitive advantages. The experience of the advanced capitalist countries shows that there is in fact a multiplicity of competitive factors, whether they are the use of the dynamism generated by the vitality of the nearby urban spaces; the incidence of strong social policies, especially those involving the transfer of public funds; and a characteristic dynamism of certain rural areas. However, the central question that must be answered is: how to take advantage of these potentialities of the regions' dynamism from the analysis of practices, strategies and policies between different contexts of development, strategies and political guidance, but with a common goal (towards a sustainable development of biofuels), in order to bridge the learning gaps? This paper examines precisely the configuration of two cases with known bioenergy development paths in the rural landscape, defined in the regional scope (Rio Grande do Sul – Brazil and Jämtland – Sweden) and sectoral (biofuels). Through the premise that regional innovation studies point that regions are not homogeneous areas related to history, culture, human and natural resources, population density, local economies, business sector, geography, infrastructure or governance structures, the central objective of this study is precisely to shed a first light on the idea that geographically distant regions with different political and development paths, but which currently share a common vision on sustainability<sup>2</sup>, can achieve by learning, through the analysis of their governance systems, ways to develop smart, sustainable and inclusive appropriate strategies based on their potentialities.

## **2. RESEARCH DESIGN**

### **2.1. Theoretical approach**

Some core concepts will guide this analysis. First, the concept of innovation systems allows a systemic view on the actors and the relationships that are established between them, especially regarding the processes of generation, use and diffusion of knowledge and innovation. Also, the design of Innovation Systems allows an analysis of the innovative process in different scopes (national, regional and sector). It is a theoretical construct based on the studies of Lundvall (1988), Patel & Pavitt (1994), Malerba (2002) and others. The regional dimension has been added and deeply analyzed by Cooke (2005, 2012), Etzkowitz (2002), Foray et al. (2009), and Lundvall (2005) - this reflects the growing acceptance that the key factors impacting competitiveness and innovation are largely determined systemically and at the regional level.

---

<sup>2</sup> (e.g. Paris Agreement on Climate Change, EUROPE 2020 Strategy).



Also, and more specifically, the case of bioenergy/biofuels has been analyzed by Carrosio (2008), Lindblom and Rasmussen (2008), Mangoyama and Smith (2011), OECD, 2012 report and others. According to Lundvall (2005), innovation could be better understood if fostered from the regional or even more local level, because it relies on embeddedness and social capital with shared values and experiences<sup>3</sup> comprising an institutional arrangement involving a series of participants (companies and their cooperation networks, governments, universities and research institutes, financial sector, among others) that interact and articulate among themselves. As part of the complexity of the bioenergy production this work interacts with the concepts of governance (Le Galès 1998), multi-governance systems (Gualini 2008; Lidström 2007) and more specifically in the light of territorial governance (DAVOUDI et. al 2008; ESPON, 2013). As a descriptive construct, governance can be a conceptual tool to trace the emergence new intersectoral issues like climate change adaptation (Kern and Bulkeley 2009). Also, is important to mention studies concerning the development of quadruple and quintuple helix approaches (CARAYANNIS and CAMPBELL, 2011). Another important idea in this field of studies is that the literature on regional innovation systems has highlighted the vast richness and diversity of regional innovation patterns, showing that there are no “one size fits all” policies according to Tödtling and Trippel (2005). Connecting to this idea, and important to guide the premises of this work, the concepts of smart growth, based on knowledge and innovation, sustainable growth, promoting a more resource efficient, greener and competitive economy, and inclusive growth, fostering a high employment economy delivering economic, social and territorial cohesion (Europe 2020) and Smart Specialization<sup>4</sup> (Foray, 2009), are fundamental concepts that can be applicable in any country or region on the globe acknowledging that they differ with respect to areas of strength and potential. Regarding biofuels, the term is referred to liquid, gas and solid fuels predominantly produced from biomass. Biofuels include bioethanol, bioethanol, vegetable oils, biodiesel, biogas, bio-synthetic gas (bio-syngas), bio-oil, bio-char, Fischer-Tropsch liquids, and biohydrogen. Most traditional biofuels, such as ethanol from corn, wheat, or sugar beets, and biodiesel from oil seeds, are produced from classic agricultural food crops that require high-quality agricultural land for growth (DEMIRBAS, 2008). Although biofuels industry has been identified as a potential sector for development at the regional level (Bomb et. al, 2007; Demirbas, 2009; La Revere et.al, 2011) and represent a key player for energy security reasons and to the development rural sector, it should be noted however, that its production and use at global level, while having advantages, also presents limitations and constraints. First, the huge array of different policies can impact positively or negatively biofuels development being a conditioning factor to the development of regions (DOORNBOSCH, 2008). Second, addressing biofuel issues requires dealing with complex problems featuring multiple interests, conflicting objectives, different types of data and information, high uncertainties and the need to account for evolving socio-economic systems (Gnansounou, 2011; Turcksin et al., 2011). Also, literature, already provides various papers that question the sustainability of biofuels (Markevičius et al., 2010; Torres et al., 2013). This debate leans mainly over three issues: the food x fuel dilemma, concerns about social inclusion and environmental impacts. The key to a sustainable development is how to promote new models and enhance the existing ones (e.g.

---

<sup>4</sup> The place-based approach is the backbone of cohesion policy for the period 2014-2020, including the existence of National/Regional Research and Innovation Strategies for Smart Specialization (RIS3). National and regional authorities develop research and innovation strategies with a place-based approach in order to allow, in particular, a more efficient and effective use of the funds and, in general, an increase in synergies between community policies, national and regional strategies. The concept of smart specialization acquires special relevance in the EU 2014-2020 programming framework particularly because of the integrated approach that the European Commission has designed for the Regional and Cohesion Policy funds through the common strategic framework and the establishment of priorities and results to be achieved.

technologies and governance systems) towards a more sustainable bioenergy/biofuel<sup>5</sup> production. Starting from the idea that the development of bioenergy nowadays is following observable and comparable patterns through adoption of common goals such as joint climate agreements and strategies between countries (e. g Europe 2020<sup>6</sup>), and despite the most of studies that make comparisons or benchmarking in the field of bioenergy are carried out within similar regions, good practices are being observed in in several regions around the world, thus a geographical distant transnational learning approach could be a potential way to promote a sustainable development between regions/nations. In short, the theoretical framework aims to approach the renewable energy and regional development policies, practices and strategies in the case studies.

## 2.2. Research question

Following the paths outlined by the theoretical support described in the previous section, this paper tries to answer the following question:

- What lessons can be learned from the studied regions in order to bridge the gap between their respective development strategies?

## 2.3. Methodological Approach / Research methods

This paper uses a qualitative approach based on the analysis of two case studies. According to Yin (1984), a case study research is an empirical inquiry that investigates a contemporary phenomenon within its real-life context when the boundaries between phenomenon and context are not clearly evident and in which multiple sources of evidence are used. Apart from scientific publications obtained through a review of literature (e.g Scopus, Google Scholar, Thesis Databases) consultations were made in reports and official documents of government bodies and industries regarding the biofuels sector. Case studies were analyzed paying particular attention in the enabling and constraining factors in the biofuels development of the studied regions.

To achieve the results, an adapted SWOT analysis was performed, changing opportunities and threats to enabling and constraining factors to better define strategic opportunities for each region and more specifically, being the focus of this paper, has enabled the analysis of opportunities between regions towards a smart, sustainable and inclusive growth. A given region should not develop pure copies of policies designed and used in other regions, instead, it needs to take advantage of the good practices from other regions to develop its own strategies. In this context, this paper complements its analysis under the concept of *benchmarking*<sup>7</sup>, based mainly in the work of Navarro et. al (2012), being generally understood to be an improvement and learning method based on comparisons and the application of the knowledge generated from them (Huggins, 2008), and points out, that benchmarking analyses have evolved substantially and instead of merely pursuing a “copy and paste” approach, this type of analysis recognizes relative strengths and weaknesses and examines performance areas using more cost-effective and efficient processes than those based on “trial and error”.

<sup>5</sup> Current efforts are mainly focused on the development of so-called second-generation biofuels. Goldenberg (2007), points that second-generation fuels use different technologies to produce it when compared to the classic and secular way of producing them. Bioethanol and biodiesel produced from forest residues and waste oils are considered second-generation biofuels.

<sup>6</sup> Europe 2020 Strategy is a guiding document that serves as a point of reference for European regions to lay the foundations on their growth paths. It defines and quantifies the main objectives that the European Union aims to achieve in the year 2020 in the areas of research and innovation, climate change and energy, employment, education and poverty reduction.

<sup>7</sup> While benchmarking was born in the business field, more recently it has been extended to also cover territories. In case of comparing one region with others, several options arise: regions can be chosen according to criteria such as localization, economic structure or high performance. More simply, they can be regions that wish to enhance cooperation and learn from each other.

## **2.4. Limitations**

This paper cannot properly be considered as a comparative analysis, since it does not deeply compare strictly the same attributes and conditions between the two regions, but rather seeks to find elements that can fill the gaps of the raised issues. In respect to the depth of this work, as has been said previously, its purpose is to shed light on a point of view that has been little discussed. It should be mentioned that this paper is part of the initial design of a PhD. thesis that is being developed at the University of Aveiro, which due to the extend and complexity of the theme (e.g policy integration, institutional framework, cultural and economic aspects, climate, geographical aspects, multi-governance analysis), will carry a much more in-depth analysis involving multiple regions based on a proposed framework.

## **3. CONTEXTUALIZATION OF THE STUDY**

### **3.1. Biofuels in Sweden**

The Nordic countries have been able to invest in their natural resources as sources of wealth, generating competitive advantage with other European countries and outsourcing innovation and technical improvement to other sectors of their economies. The National Systems of Innovation in the Nordic countries are justified by the economic leap that these countries obtained after World War II, achieving the leadership of the worldwide socioeconomic development. Unlike the Latin American countries that imported technology, the Nordic countries, in order to overcome the underdevelopment barrier, used the process of catching up, integrating the knowledge of technology with the capacities of foreign resources, through the creation of so-called "technical societies", responsible for the dissemination of knowledge at the national and regional level (BRULAND and SMITH, 2010). During the 1990s, Sweden became a member of the European Union which meant a new structure for the regional policy where the national policy was replaced with the common policy. This favoured specialisation for different regions in contrast to earlier national policy. Also at the local level, the municipalities have been involved in facilitating the national efforts to meet EU targets regarding the transition to low carbon economy, and have contributed to building up the social acceptance and political legitimacy of bioenergy (HILLRING 2012). At European Union level, renewable energy sources have gained new impetus as a result of policies favoring their use. In April 2009, the EU adopted a new directive to promote the use of energy from renewable sources. The directive (Directive 2009/28/EC) sets clear directions on Europe's energy-environment evolution and establishes a common vision, where each member state has to reach a specific target, so that the Union will ultimately have 20% of its energy matrix based on renewable sources by the year 2020 (with a minimum of 10% renewable energy for transportation, which increased attention to biofuels production). It jointly established requirements to ensure that biofuels used to meet this target were produced in accordance with sustainability criteria by the year 2020. The directive also contains a roadmap to reduce 20% of total GHG emissions over the same period, and defines a strategic plan for the development and implementation of technologies (SET-Plan) to reduce dependence on oil in the EU (EUROPEAN UNION, 2009). From the national authority level Sweden aims at becoming carbon neutral in 2045. In order to achieve the set targets to have a carbon free vehicle fleet until 2030, Sweden has the choice of taking several actions where one option should be the establishment of biofuels in a larger scale (TEKNISKA VERKEN, 2016). At this moment, the Swedish share of biofuels in the transport sector is larger than 10%, meaning the 2009 EU directive is fulfilled (Svebio, 2016). However, the Swedish government is taking the lead for the use of renewable energy by setting a goal that until 2050 there should be zero greenhouse gases released to the atmosphere from any activity in Sweden. Regarding the transport sector, the vehicle fleet should be independent from fossil fuels in 2030 (Swedish Government, 2016).

### *3.1.2 Biofuels in Jämtland*

Jämtland is a forest-rich rural region with good regional practices in the development of bioenergy, and is among the most populous sparse regions in Sweden and the EU (OECD, 2012). Forest biomass is used for the production of heat, electricity, pellets and other biofuels. Urban heating is almost entirely fueled by biomass. The forestry sector has undergone a major structural change in the last five decades and local energy production has become an important regional specialization in Jämtland. In 2002, a combined heat and power plant with biomass was inaugurated. The plant produces electricity and heat and uses wood, peat, forest residues and logging wastes such as branches and tops that comes mainly from the area around Östersund. Östersund is also one of the pioneers of Biogas. It is important to mention that small-scale biogas plants on farms are very widespread in the region and farmers are interested in participating in this development. With the 1973 oil crisis, the state took steps to support the diversification of energy sources. As a fairly cheap energy source, forest biomass was particularly appreciated. The use of biomass for energy production was facilitated through the availability of local resources and their low cost, driven by increased taxes on oil consumption and the introduction of the CO<sub>2</sub> tax. The role of local political and individual leadership for the development of bioenergy has also been important in the context of the municipality of Östersund. While the development of bioenergy is largely influenced by the national agenda and EU policies, which indicate downstream processes, lower levels of governance have important responsibilities and role in the development of bioenergy. Regional and local governments develop their own agenda linked to national and EU objectives. The climate goal of the municipality of Östersund is to reduce GHG emissions by 60% by 2020 and pledged to make the transport sector in the municipality independent of fossil fuel by 2030. Actions to this include a greater mix of biofuels in fossil fuels and increased use of liquid biofuels through the Green Highway initiative. The Green Highway initiative has become a trademark of the region. It promotes fossil fuel-free transportation and aims to boost green technology investments. The commercialization of advanced biofuels for transport is among the national priorities in Sweden as the government has set the goal of an independent fossil fuel transport sector by 2030 (MIKKOLA, 2017). In the case of biodiesel production, the region produces mainly first generation FAMES<sub>3</sub> (transesterification process) and HVOs (hydrotreatment process) that are produced from food crops. According to Svebio (2017), during the first half of 2016, biodiesel accounted for almost a quarter (23.8%) of all diesel fuel delivered to the Swedish transport fuel market. Regarding the role of universities in the development of bioenergy, Jämtland has a relevant research in environmental science and other relevant fields. A variety of baccalaureate programs are held in Mid Sweden University at the Östersund Campus, such as the Bachelor Program in Ecotechnology, Eco-engineering, Eco-entrepreneurship for sustainable development, and Mechanical Engineering. In addition, the regional development strategy for Jämtland County 2014-2030 are closely linked to the objectives of the EU 2020 strategy: smart growth in entrepreneurship, innovation, research and development; smart skill growth and knowledge development; smart growth in resource efficiency and efficiency; sustainable tourism growth; sustainable growth in community infrastructure and services; social inclusion and healthy lifestyles and demographic opportunities (Region Jämtland Härjedalen, 2014).

### **3.2. Biofuels in Brazil**

Brazil shows decades of experience in the production of ethanol biofuel extracted from sugarcane. After the first oil price crisis in 1973/1974, the Pró-Álcool Program was initiated in Brazil in 1975 to reduce dependence on oil imports. Since 2006, Brazil has been self-sufficient in oil supplies, which means that the new euphoria for expanding biofuel production is attributed to the international discussion on climate change and attempts to increase renewable energy production with consequent reduction of CO<sub>2</sub> emissions, naturally targeting the huge

rise in the price of fossil energy (RATHAMANN et al., 2005). The potential of biofuel in Brazil strengthens its position as a regional power with global influence and guarantees its claim as a political leader in Latin America. The latest developments in the biofuels sector show that Brazil undergoes a comprehensive process of transformation, leading not only to enormous economic consequences but also in domestic policy leading to social, sociocultural and ecological changes. This is followed by analyzes of energy, agrarian, social and environmental issues, based on the example of ethanol and biodiesel production. According to Hall et. al (2009), there was a belief within policy circles that the success in agriculture had brought detrimental side effects along with it such as the dislocation of subsistence farmers, a widening gap between rich and poor, increased violent crime and other social exclusion problems. Resolving these concerns became a recognized policy concern and a main agenda of the first Lula government (2003-2006). Being part of this transformation, in 2004, Brazilian government launched the PNPB (National Program for the Production and Use of Biodiesel), that was a Brazilian response to what has been carried out worldwide since the mid-1990s in the field of research and production of alternative energy to oil, and whose main guidelines are: i) sustainable introduction of biodiesel in the energy matrix; ii) promote the generation of employment and income for family farmers (main objective); (iii) to promote the reduction of regional disparities (differentiated actions at the regional level); (iv) contribute to a reduction in pollutant emissions; v) reduction of import volume of diesel oil; vi) provide fiscal and credit subsidies; and (vii) to provide flexible regulation (raw material and technological process or route). This program aimed to differentiate itself from the attempts of the 1970s and 1980s, through its strong social focus, namely, the integration of family agriculture into Agribusiness of Biodiesel. To this end, the government provided a set of policy instruments, such as the creation of a compulsory market, partial or total tax exemption from federal taxes; promoted the standardization of ICMS; credit subsidies; creation of the Social Fuel Seal. The social inclusion of family farmers in the biodiesel production chain uses the Social Fuel Seal (SCS) with a tool that specifies, through the Normative Instructions of the Ministry of Agrarian Development, the minimum percentages of raw material that biodiesel producers must obtained from family farmers in order to be certified (GARCEZ; VIANNA, 2009). The PNPB placed Rio Grande do Sul as an important State in this scenario. Stattman and Mol (2014) in evaluating Brazilian rural development policies says that PNPB social sustainability policy came with new governance instruments and arrangements in which agricultural cooperatives were given—and assumed—a central role. Thus far, this social biodiesel policy has resulted in more biodiesel company contracts with family farmers who produce vegetable oils (often through cooperatives). However, some issues are observed (e.g. lack of technical assistance to the family farmers and lack of commitment of the families with the producing companies) putting at risk the current development of the social model. It is important to mention that the Ministry of Mines and Energy (MME, 2017) launched the RENOVABIO program in December of 2016, which aims to expand biofuel production in Brazil, based on predictability, environmental, economic and social sustainability, and compatible with the growth of market and with a long-term self-imposed goal (2030).

### *3.2.1 Biofuels in Rio Grande do Sul*

Rio Grande do Sul is among the regions in Brazil that have stood out in the emergence of agro-industries producing biodiesel<sup>8</sup>. Favorable factors, highlighted for the formation of this new productive chain in the State, are the edaphoclimatic conditions for soybean cultivation and the possibility of the introduction of new oil crops, as well as the historical organization of family agriculture (NEUTZLING; PEDROZO; SANTOS, 2009). The construction of this new

---

<sup>8</sup> Most bioenergy production in Rio Grande do Sul (RS) is due to Biodiesel. Other initiatives (e.g biogas, ethanol) were not considered in this research because there is no consolidated information due to the low degree of development of their respective chains.

scenario from the implementation of the biodiesel production chain was based on the already consolidated commodity (soybean) with the large producing agroindustries being the main actor - according to the rules of the National Program of Production and Use of Biodiesel (PNPB) and mainly seeking to comply with the economic, social and environmental dimensions. There are 9 biodiesel production plants installed in Rio Grande do Sul (ANP, 2018). These plants can only operate with the authorization of Petrobras, and must sell their production through regular auctions. Also, due to the fact that industries have to buy a large part of their production from rural families, the development and creation of the cooperatives was encouraged. Regarding the institutional arrangement focused on biodiesel in the State, several state agencies are active. The Secretariat for Science, Innovation and Technological Development (SCIT) coordinates the Gaúcho Biodiesel Program (PROBIODIESEL / RS), established in 2003 in line with the PNPB. In addition, the project involved the Brazilian Agricultural Research Company (EMBRAPA), the Technical Assistance and Rural Extension Company (EMATER), cooperatives and several universities in the State. Also, the government, under the coordination of the Secretariat of Agriculture, Livestock and Agribusiness (SEAPA / RS), set up the Thematic Chamber of Agroenergy in 2011. The aim was to unite the different actors involved with the production of biofuels (biodiesel, ethanol, biogas) and discuss issues related to agroenergy. With regard to investments and financing, the State Government, through the Rio Grande do Sul State Operational Fund (FUNDOPEM / RS) and the Rio Grande do Sul Industrial Development Harmonization Program (INTEGRAR / RS), provide substantial financial benefits to the industry

#### 4. RESULTS

The swot analysis combining with the concepts of benchmarking aims, through the observation of the main enabling and containing factors (table 1 and 2), provide insights to the definition of strategies for the regions (tables 3 and 4) and after that, between the studied regions (discussion session). This methodology acts also as a facilitating tool to organize and summarize a large amount and relevant information (in addition to the information presented in previous sessions - due to the limited extension of this paper) obtained through the documentary analysis.

<b>Jämtland, Sweden</b>	
<i>Enabling factors</i>	1 Consolidated expertise in the forestry sector;
	2 Strong political support and backing by the municipal and regional authorities;
	3 University Programs in the field of environmental technology and renewable energy
	4 Strong national financing measures;
	5 Public procurement (GPP);
	6 Regional development strategy which is closely linked to the objectives of the EU 2020 Strategy;
	7 Soft forms of regulation (i.e. non-binding municipal and regional strategies);
	8 Support from EU funds and initiatives like Smart Specialization;
	9 Climate Strategy for Jämtland 2014-2020;
	10 Certificate trading system and tax regulation mechanisms.
<i>Constraining factors</i>	11 Sparsely populated settlement structure;
	12 Due to current low energy prices collecting and selling logging residues is not economically viable;
	13 Low energy prices;
	14 Uncertain framework at the EU and national level;
	15 Rapid increase in the interest in electric and fuel cell vehicles, which questions the role of biofuels in future;
	16 Jämtland's remote location;
	17 Low attractiveness to people with technical university education to remote and rural areas.

**Table 1 – Enabling and constraining factors of biofuels production in Jämtland, Sweden.**

## Rio Grande do Sul, Brazil

<i>Enabling factors</i>	1	Strong government incentive to social inclusion;
	2	Potential to diversify the production of biodiesel with the use of waste from the management of eucalyptus, pinus and acacia towards a second-generation biodiesel;
	3	Tradition of the Rio Grande do Sul state industry in the metal-mechanic segment;
	4	Existence of several educational institutions and research institutes;
	5	Good tax policies and interest rates;
	6	Discussions are encouraged between biodiesel, ethanol and biogas sectors to discuss issues related to agroenergy.
<i>Constraining factors</i>	7	External Biofuels/Climate Change Policies;
	8	Little to none development towards 2nd generation biofuel;
	9	Market is highly consolidated and dependent on a single commodity (soybean);
	10	Lack of Universities' planning and/or regional and federal incentives for the creation of formal programs related to the development of bioenergy;
	11	Competition with another source of energy production;
	12	Lack of mechanisms / regulation for monitoring social and environmental impacts (weak governance systems);
	13	Oligopoly biofuel production;
	14	Environmental impacts resulting from the large-scale generation of the first generation of biodiesel;
	15	Lack of an effective policy focused on innovation;
	16	Lack of mechanisms and policies for the mitigation of environmental impacts;
	17	Lack of skilled labor.

Table 2 – Enabling and constraining factors of biofuels production in Rio Grande do Sul, Brazil.

Jämtland, Sweden		<i>Enabling factors</i>									<i>Constraining factors</i>								
		1	2	3	4	5	6	7	8	9	10	11	12	13	14	15	16	17	
<i>Strengths</i>	Optimized farming and management methods		x	x	x				o	o	o							o	
	Small scale bioenergy plants expertise		x	o	x			o										o	
	Projects and initiatives providing advice to private persons and businesses on energy efficiency and renewable energy issue		x	x				x		o	x					o	o		x
	Strong R&D cooperation with Universities	o	x	x	o			o	x	o	o					o			
	Strong networking between actors in the region		x		o			x	x	o	x					o	o		
<i>Weaknesses</i>	Diversified production of bioenergy (biodiesel, biogas, bioethanol)	o	x	x	x	x	x	x	o	o	x	x	x	x	o	o	o	x	
	The transport sector is lagging behind in terms of renewable fuels use and is still highly dependent on fossil fuels	o	o	o	o	o	o	o	o	o	o	x	o	x	o	o	x	o	
	There is little support to innovation and market development of biofuels	o	o	o	o	o	o	o	o	o	o		x	x	o	o		x	
	Almost no energy crops are cultivated in the region today	o		o	o			o	o	o	o				x	x	x	x	x
	Production of liquid biofuels is mostly focused on non-advanced biofuels	o	o	o	o	o	o	o	o	o	o			x	x	o	x		o

x - Current affecting factors  
o - Potential affecting factors

Table 3 – Adapted SWOT analysis of biofuels production in Jämtland, Sweden.

Rio Grande do Sul, Brazil		Enabling factors						Constraining factors										
		1	2	3	4	5	6	7	8	9	10	11	12	13	14	15	16	17
Strengths	Consolidated expertise of biofuels cooperatives	x	o			x												
	Large-scale industries expertise	x	o	o	o	x	o		o	o	x	o					x	x
	A dedicated regional program on biodiesel	x	o	o	o	x	o	o	o	o	o	o	o			o	o	o
	Active state bodies like the Secretariat for Science, Innovation and Technological Development (SCIT)	x	o	o	o		o	o	o									
	High investment and financing by the Government of the State of Rio Grande do Sul	x	o	o		x	o	o	o	o	o	o	o			o		o
	Multi-stakeholder collaboration in the implementation of biodiesel industries	x	o	o	x	x		o	o	o	o		o			o		o
	Joint financing initiatives between regional banks and national development agencies	x	o	o	o	x	o	o	o	o	o	o	o			o	o	o
	Geographic proximity of industries is close to regional cooperatives and producers of oilseeds	x	o							o			o					
	Innovations based on new management methods to meet certification standards	x	o		o		o	o	o		o				o		o	
Weaknesses	Privileged geographic location for the production of first generation biodiesel		o		o			o										
	Low capacity for technological innovation		o	o	o	o	o	o	o	x	x	o		x		x		x
	Low interaction between the relevant actors				o		o					o				x		
	Low to no diversification of the biofuel type	o	o	o	o	o	o			x	x	o		x		x		o
	Difficulty attracting and maintaining skilled labor		o	o	o					o		x				x		x
	Lack of local/regional climate policies/goals	o	o		o	o	o				x		x					
	Technology is dependent on European companies		o	o	o	o	o			x	x			x		x		x
	Centralization of the commercialization of biodiesel		o				o	o	x				x			x		
	Weak relationships with Universities		o	o	o				o		x							x
There is no cooperation, even informal, between biodiesel producers				o		o			x	o	x		x		x			
Lack of formal internal learning sources such as departments and R&D laboratories		o	o	o	o				x	x			x	x			x	
Lack of formal Universities' programs on bioenergy/regional development		o		o				o	o	x					x			

x - Current affecting factors  
o - Potential affecting factors

Table 4 – Adapted SWOT analysis of biofuels production in Rio Grande do Sul, Brazil

## 5. RESULTS

From the analysis of the Swot matrix, it was possible to provide some insights for the two studied regions in how to develop strategies and to correct some inefficiencies towards a better integration between the actors and a more sustainable development of biofuels. In addition, it is possible to observe that there is much room for learning and joint cooperation, taking advantage of the strengths and weaknesses of the regions. However, some points should be highlighted for a better understanding and development of this possible interaction / integration between the two regions. Due to Swedish climate goals and the need to increase the production of biofuels (mainly biodiesel for transport), the Rio Grande do Sul consolidated experience in large scale may be of great value to the development of the Jämtland region. Regarding the sources/types for biofuels productions, the two studied regions have opportunities to develop. Jämtland has enormous potential for forest raw materials with an already consolidated expertise in the field, which can be a determining factor for the development of second generation biofuels. Rio Grande do Sul can use this expertise to begin a strategy regarding second generation biofuels as well as Jämtland's expertise in small scale biogas production to diversify its production and through models of decentralized biofuel production. It is clear that second generation biofuels will play a central role in the decarbonizing of the transport market, but to achieve this, policies should be flexible and supportive. The gaps of governance need to be closed and bottom-up processes linked to top-down ones in the course of cross-sectoral and cross-level cooperation. In this context, networks are being increasingly recognized as appropriate modes of action and cooperation for the development of a flexible actor systems. It can be observed that biofuels governance in Jämtland took place through new and innovative institutional practices, while in Brazil this practice is practically non-existent, which becomes



a barrier towards an integrated sustainable development. It is important to mention that even in Jämtland case, difficulties can arise from this multi-governance due to their complex system of interactions. Universities can play a key role in this multi-governance system. It can be concluded that in Rio Grande do Sul, although the existence of research and higher education institutions is identified, there is still a tenuous interaction with the private productive sector. In general, there is a low interaction between companies and universities/research institutes. The points of interaction of the producer companies with the universities are mainly focused on the training of the workforce and not on scientific research and technology transfer. The industry thus loses its capacity to use scientific studies to advance the diversification of raw materials and reduce dependence on soybeans. This can clearly be surpassed by adopting the Swedish model in the construction of formal programs in the Universities linked to Bioenergy and its connection with rural areas. Regarding innovation itself, producer companies in Rio Grande do Sul innovate in a restricted way. When they do, they innovate technologically exclusively in process, via purchasing of machinery and adjustments in the manufacturing process. Some companies also implement organizational changes and considering this as an innovation. They perceive themselves as the main responsible for such innovations and point to their own experience in the production process as an important source of learning. Based on this set of information, it was verified that the innovative sectoral system of Rio Grande do Sul biodiesel is not consolidated and its lagging behind the Swedish / Jämtland model. Regarding the policy measures, both regions have interesting initiatives that can be harnessed through a deeper analysis, verifying their possible adaptation in another scenario(s). For instance, Jämtland uses 'soft' forms of regulation (i.e. non-binding municipal and regional strategies), which are often more ambitious than the national strategies and targets and green public procurement (GPP) in order to promote greener solutions, boost innovation and create incentives for continuous improvement of the environmental performance of private sector companies. Otherwise, Social Inclusion model promoted in Brazil/Rio Grande do Sul can be an example of a regulation that can help to develop the large-scale production of Swedish biofuels and at the same time promote the social inclusion of small producers. However, even though it is a success factor in the Brazilian biodiesel program, it is necessary to pay attention to some negative impacts already perceived. Some of the main constraints on small family farmers' inclusion include: lack of high-quality agricultural land and production support such as financing, machinery, supplies, and assistance; climatic issues; lack of good quality roads; poor management and cooperative operation; and difficult access to credit policies (Carvalho, Potengy, and Kato 2010). In addition, the lack of regional and local climate/energy and goals and policies in Rio Grande do Sul can be considered a potential future issue<sup>9</sup> that can be mitigated through collaboration with Jämtland's local governments, in a possible diffusion of local knowledge and policies.

This exchange of strategies can be achieved in many ways, such as through the sharing of structured information, joint seminars and conferences, agreements between universities and between universities, business and government, bilateral cooperation agreements, among others. However, a more in-depth research is needed to understand in a more efficiently way, the processes in which diffusion of policies and strategies among politically different complex regions can take place. Also, to boost innovation, the Smart Specialisation approach (S3) is being an inspiratory driver of regional innovation not only within the EU but also beyond. S3 can promote the enhancement of territorial capacities by maximizing innovation with and from local resources, players and know-how. Some Latin American countries are integrating the S3 approach in policies oriented to empower regional innovation.

---

<sup>9</sup> Regional biofuels goals are under national guidelines that have a weak governance system, mainly concerning compliance of social-environmental aspects.

The European Commission recently (2016) released an international cooperation with Brazil reinforcing the cooperation on research and innovation in areas like bioenergy, which may be essential for the development of smart specialization strategies between countries / regions. The Brazilian Strategy for Science, Technology and Innovation (ENCTI) 2016-2019 also underlines the contribution to the generation of qualified jobs, to combat poverty and social inequality and seems to be aligned with the precepts of the recent European strategies.

## 6. CONCLUSION

The different debates about governance in the biofuels market imply not only discussions related to strategies, instruments and mechanisms of socio-environmental management, but also involve the relationship of countries, societies, institutions, organizations and individuals with the provision of socioenvironmental impacts. Bioenergy will continue to be a key subsector in shaping regional/rural economies, rural regions can benefit economically as the costs of remoteness in the centralized petro-economy are replaced by the benefits of space in the distributed bioeconomy. The potential benefits will be achieved only if bioeconomy includes safeguards for renewable resources and mechanisms that ensure an equitable distribution of the rewards from investment. Coordinating regional actors and national stakeholder through appropriate transnational governance structures is therefore of primary importance. De man and German (2017), shows that in the recent literature on governance, there is a growing body of highlights showing the deficiencies of public governance of biofuels. These concerns arise from the complexity of biofuels - they present an interconnected and multidimensional phenomenon that interacts with diverse policy domains (including agriculture, environment, energy, economics, technology and innovation, international development and so on), across different geographies, scales and timeframes. Biofuels are supported and opposed by a range of different discourses, creating tension and triggering extensive debate about the nature and desirability of their development. In this context, it is necessary to think of new ways of solving sustainability problems - promoting regional and rural development - taking advantage of the new forms of expertise that emerge in the most diverse regions of the world.

## LITERATURE:

1. Bomb, C.; McCormick, C.; Deurwaarder, E.; Kåberger, T. (2007). Biofuels for transport in Europe: Lessons from Germany and the UK. *Energy Policy*, vol. 35, Issue 4, 2256-2267.
2. Brasil. ANP. Agência Nacional do Petróleo, Gás Natural e Biocombustíveis. (2018). Relatório mensal do Biodiesel.
3. Bruland, K.; Smith, K. (2010). Knowledge Flows and Catching-Up Industrialization in the Nordic Countries: The Roles of Patent Systems. In: ODAGIRI, Hiroyuki et al (Ed.). *Intellectual Property Rights, Development, and Catch-Up: An International Comparative Study*.
4. Carayannis, E.G.; Campbell, D.F.J. (2011). Building on the Quadruple and Quintuple Helix Innovation Concepts and the ‘Mode 3’ Knowledge Production System. *Journal of the Knowledge Economy*, 2 (3), 327–372.
5. Carrosio, G., (Eds.), (2008). *I distretti rurali delle energie rinnovabili e la produzione locale di energia*, Equal Energia Solidale, Research Report.
6. Carvalho, R. L. de.; Potengy, G. F.; Kato, K. (2010). “PNPB e sistemas produtivos da agricultura familiar no Semiárido: oportunidades e limites.” III Congresso da Sociedade Brasileira de Sistemas de Produção, São Luis/MA.
7. Cavicchi, B.; Bryden, J. M.; Vittuari, M. A comparison of bioenergy policies and institutional frameworks in the rural areas of Emilia Romagna and Norway. *Energy Policy*, vol. 67, 355-363.

8. Cooke, P. (2012). Transversality and Transition: green innovation and new regional path creation. *Eur. Plann. Stud.*, 20 (5), 817-834.
9. Cooke, P.; Clifton, N.; Oleaga, M. (2005). Social capital, firms embeddedness and regional development. *Reg. Stud.*, 26 (8), 1065-1078
10. Davoudi, S., Evans, E.; Governa, F.; Santangelo, M. (2008). “Territorial Governance in the Making. Approaches, Methodologies, Practices”, in: *Boletim de la A.G.E.N.*, n. 46.
11. De Man, R and German, L. (2017). Certifying the sustainability of biofuels: Promise and reality. *Energy Policy*, vol. 109, 871-883.
12. Demirbas, A. Biofuels securing the planet’s future energy needs. *Energy Conversion and Management*, vol. 50, Issue 9, 2239-2249.
13. Doornbosch, R.; Steenblik, R. (2008). Biofuels: Is the cure worse than the disease?. *Revista Virtual REDESMA*. 2008, vol.2, n.2, 63-100.
14. Edquist, C. (2004). Reflections on the systems of innovation approach. *Sci. Public Policy*, 31 (6), 485-489. Oxford University Press.
15. ESPON TANGO. (2013). Territorial Approaches for New Governance. Scientific Report. European Commission.
16. Etzkowitz H. (2002). The Triple Helix of University – Industry – Government. Implications for Policy and Evaluation, Science Policy Institute, Stockholm, Working Paper:11.
17. Foray D., et al. (2009). Smart Specialisation—The Concept. Knowledge Economists Policy Brief no. 9, June.
18. Garcez, C.A.G.; Vianna, J.N.D.S. (2009). Brazilian biodiesel policy: social and environmental considerations of sustainability. *Energy*, v. 34, n. 5, 645-654.
19. Gnansounou, E. (2011). Assessing the sustainability of biofuels: A logic-based model. *Energy* 2089–2096.
20. Gualini, E. (2008). ‘Territorial cohesion’ as a category of agency: the missing dimension in the EU spatial policy debate, *European Journal of Spatial Development*, Refereed Articles, 28, 1-22.
21. Hall, J.; Matos, S.; Severino, L.; Beltrão, N. (2009). Brazilian biofuels and social exclusion: established and concentrated ethanol versus emerging and dispersed biodiesel. *Journal of Cleaner Production*, vol. 17, Supplement 1, S77-S85.
22. Hillring, B. (2002). Rural development and bioenergy—experiences from 20 years of development in Sweden. *Biomass and Bioenergy*, vol. 23, Issue 6, 443-451.
23. Le Galès P. (1998). Regulation and Governance of European Cities, *International Journal of Urban and Regional Research*, Vol. 22, n. 3, 481-506.
24. Lidström (2007). Territorial Governance in Transition, *Regional and Federal Studies*, vol. 17, n. 4, 499-508.
25. Lindblom, G.P.; Rasmussen, O.R. (2008). Bioenergy and Regional Development in the Nordic Countries, Nordregio.
26. Lundvall, B-Å. (1988). “Innovation as an Interactive Process: From User-producer Interaction to the National System of Innovation,” in G. Dosi, C. Freeman, R. Nelson, G. Silverberg, L. Soete (eds.), *Technical Change and Economic Theory*. London and New York: Pinter Publisher.
27. Lundvall B.Å. (2005). Interactive learning, social capital and economic performance, advancing knowledge and the knowledge economy. In: Conference Organized by EC, OECD and NFS-US, Washington, January 10–11.
28. Mangoyama, B.; Smith, T.F. (2011). Decentralized bioenergy systems: a review of opportunities and threats. *Energy Policy*, 39, 1286-1295.
29. Markevičius, A.; Katinas, V.; Perednis, E., Tamašauskienė, M. (2010). Trends and sustainability criteria of the production and use of liquid biofuels. *Renew. Sustain. Energy Rev.* 14, 3226–3231.

30. Mikkola, N. (2017). Bioenergy development in North Karelia, Finland. Nordregio Working Paper.
31. Navarro, M.; Franco, S.; Murciego, A.; Gibaja, J.J. (2012). Metodología de benchmarking territorial: la necesidad de identificación de las regiones de referencia. *Información Comercial Española* 869: 115-132.
32. Neutzling, D. M.; Pedrozo, E. A.; Santos, T. S. (2009). Estruturação da cadeia produtiva de biodiesel no Estado do Rio Grande do Sul na percepção de especialistas. Porto Alegre: Sober.
33. OECD (2012). Linking Renewable Energy to Rural Development. OECD Green Growth Studies, OECD Publishing. <http://dx.doi.org/10.1787/9789264180444>.
34. Rathmann, R. et al. (2005). Biodiesel: uma alternativa estratégica na matriz energética brasileira? In: Anais do seminário de gestão de negócios. Curitiba (PR): UNIFAE, 2005.
35. Sachs, I. (2004). Desenvolvimento: incluyente, sustentável, sustentado. Rio de Janeiro: Garamond.
36. Stattman, S.L.; Mol, A.P.J. (2014). Social sustainability of Brazilian biodiesel: The role of agricultural cooperatives. *Geoforum*, vol. 54, 282-294.
37. Stoker G. (2000). Urban Political Science and the Challenge of Urban Governance, in Pierre J., op.cit.
38. Tekniska Verken. (2016). Alla icke-fossila bränslen behövs för en fossilfri fordons-flotta. Retrieved March 23, 2018, from <https://www.tekniskaverken.se/om68oss/tekniska-verken-tycker/alla-icke-fossila-branslen-behovs-for-en-fossilfrifordonsflotta/>
39. Tödting, F.; Tripl, M. (2005). 'One size fits all?: Towards a differentiated regional innovation policy approach' *Research Policy*, v. 34, n. 8, 1203-1219.
40. Torres, C. M.; Ríos, S.D.; Torras, C.; Salvadó, J.; Mateo-Sanz, J.M., Jiménez, L. (2013). Microalgae-based biodiesel: A multicriteria analysis of the production process using realistic scenarios. *Bioresour. Technol.* 147, 7–16.
41. Turcksin, et. al. (2011). A multi-actor multi- criteria framework to assess the stakeholder support for different biofuel options: The case of Belgium. *Energy Policy* 39, 200–214.
42. Yin, R.K. (1984). Case study research. Design and methods. Sage Publications.

